

JOE'S ANTIQUE AUTO



QUALITY REPRODUCTION FORD PARTS

**1932-1948 Cars &
1932-1947 Pickup**

**Fast Friendly
Service &
Prompt
Shipping**



ORDERS & INFORMATION: 1-508-278-3980

Toll Free: 1-800-508-3980 24 HOUR FAX: 1-508-278-2766

Email: joesantique@charter.net

WEBSITE: WWW.JOESANTIQUAUTO.COM

**267 W. HARTFORD AVE.
UXBRIDGE, MA 01569**

Telephone Hours: Monday-Thursday 9:00-4:30

GENERAL INFORMATION- ANTIQUE AUTO PART SALES

ORDERS & INFORMATION Call 1-508-278-3980 order through our website

E-MAIL CORRESPONDENCE joesantique@charter.net

FAX ORDER 1-508-278-2766

TELEPHONE HOURS Monday, Tuesday, Wednesday & Thursday 9:00 A.M. to 4:30 P.M. Closed Friday, Saturday, Sunday, major holidays & during Hershey car show week. Visit us by appointment **ONLY** at mutually convenient times. When visiting us always call first.

PRICES All prices in this catalog are subject to change without notice.

SHIPPING We ship using UPS or USPS priority mail both in USA & export out of country offering the lower of costs

e estimated shipping costs for the east coast and central USA only. West coast USA and Canada are higher and charged actual shipping costs. We use both priority mail and UPS, the least expensive way we can!.

Up to \$20.00.....	\$9.00	\$50.00 to \$60.00	\$18.00
\$20.00 to \$30.00	\$13.00	\$60.00 to \$100.00	\$20.00
\$30.00 to \$40.00	\$14.00	\$100.00 or more add 12% excess will be refunded	
\$40.00 to \$50.00	\$15.00		

All orders exceeding these rates will be subject to actual shipping costs. Over payments are refunded. Please add \$12.00 for COD'S. No COD for Canada shipments. Heavy or bulky items are also higher and will be charged actual shipping costs.

SALES TAX All Massachusetts residents add 6.25% for sales tax. All items picked at store also subject to this tax.

PAYMENT We accept money orders, checks, Visa, Master card and Discover.

GUARANTEE All parts guaranteed and will be replaced for 30 days when used as originally intended. In any and all cases we are liable for purchase price of part only.

DAMAGE/MISSING GOODS If merchandise was damaged in shipping or if carton arrives opened, check for damaged and/or missing goods. Notify carrier of any damage at once. Claims must be taken up with the carrier. Keep the goods in the original carton for inspection.

RETURNS Items may be returned for a full refund they have been not been used or damaged within 30 days of purchase. All parts returned must have a copy of the original invoice and an explanation for the return. Parts returned in soiled boxes or packaging will be subject to a 10% restocking fee. Special order items are non-returnable.

FORD SCRIPT PRODUCTS All Ford script products offered in this catalog are Official Licensed Products of the Ford Motor Company by the manufacturer.

Your business is always appreciated!

Reproduction of this catalog either in whole or in part without the express written consent of Joe's Antique Auto is forbidden.

Not responsible for typographical errors in this catalog.

JOE'S GIFT CERTIFICATES AVAILABLE

For that "hard-to-buy-for" relative or friend, available in any denomination

JOE'S ANTIQUE AUTO 1932-1948 EARLY V-8 FORD PARTS

A		
Accelerator Parts47	Hydraulic brake adapter set.....10	Release bearing hub & springs.....38
Foot rest.....47	Pedal to master cylinder rod...12	Release fork & pin.....38
Pedal and pedal rod.....47	Pedal pads.....14	Retracting springs.....38
Return spring.....47	Pedal springs.....14	Throwout bearing.....38
Accessories152	Pedal bushings.....38	Coil, Ignition54
Air cleaners.....48	Pedal bumpers.....14	Color Chip Books151
Bumper grille guards.....98	Rods, clevis & pin.....10	Column Shift Lever Parts35
Chrome nut covers.....30	Service brake rods & cables...10	Condensor & Parts52
Exhaust pipe tips (deflectors).....16	Shoe anchor pins & plates.....10	Connecting Rods & Parts31
Greyhound radiator caps.....43	Shoe retainer clip.....11	Convertible Pillar & Top Bow Pads100
Hinge pin puller.....105	Shoe return springs.....9,11	Convertible Top Parts100, 101
Key fobs.....152	Lining & rivet sets.....10	Wiring.....132-134
Hot rod taillights.....91	Mechanical brake parts.....9,10	Cowl
License plate frames.....99	Rivet tool.....10	Cowl To Firewall Seal, 1932...62
Rear view mirrors.....77-79	Shoe linings.....10	Lacing.....62
Running board step plates...156	Stop light switch.....12	Mirrors.....77
Spreader bars.....18	Brush Set, Generator50	Molding.....78
Trim Rings, wheel.....7	Bulbs94,95	Wiring harness.....132,133
Alternator Conversions50	Backup light.....95	Cowl Lights89
Antennas & Parts114	Cowl light.....95	Arms.....90
Armrest Kits105	Dome light.....95	Crossover wire.....132
Axle Parts, Front14-16	Halogen.....94,95	Lens & gasket.....90
	Headlight.....94	Mounting pads.....89
	Instrument panel light.....95	Parts.....90
	License plate light.....95	Reflector.....90
	Sealed beam.....94	Turn signal adaptor.....90
	Stoplight.....94	Cowl Vent Parts119
	Taillight.....94	Hinges & springs.....119
	Bumpers & Parts96,98	Plastic knobs.....119
	Arm grommets.....98	Ratchets.....119
	Bolts.....98	Rubber seal (gasket).....119
	Brackets & parts.....96,97	Handles.....119
	Bumper to body seal.....98	Screens.....119
	End plugs.....97	Crank Hole Cover57
	Guards.....98	Cranks, Window110,111
	Front/Rear gravel deflector...98	Crossover Pipe26
	Tips, 1940.....98	Cutout, Generator50
	Bumper Arm Grommets98	
	Bumpers, Rumble Lid71	
	Bumpers, Door107	
	Bumpers, Frame Axle18	
	Bumpers, Rear Window100	
	Bumper Sets, Hood63	
	Bushings, Clutch & Brake Pedal38	
	C	
	Cage & Clinch Nuts151	
	Carburetor Parts48	
	Gaskets.....48	
	Mounting studs.....48	
	Rebuild (repair) kits.....48	
	Carburetor & Gas Controls46	
	Accelerator parts.....47	
	Choke & throttle rods, dash grommets and parts.....46	
	Choke & throttle cables.....46	
	Channel, Glass131	
	Choke & Throttle Rod, Cable & Parts46	
	Clips, Frame (Wiring)133	
	Cigarette Lighter Element & Knobs118,119	
	Circuit Breakers & Resistors54	
	Clock Parts122	
	Cluster Gear & Parts36	
	Clutch38	
	Adjusting rod clevis & pin.....39	
	Brackets and balls.....39	
	Disc.....38	
	Pedal pads.....14	
	Pedal shafts & bushings.....38	
	Pilot bearing.....38	
	Pressure plate.....38	
		D
		Dash Parts
		Cigarette lighter elements & knobs.....118,119
		Clock parts.....122
		Hi-beam socket & jewels.....121
		Dash light dimmer switches..121
		Instrument panel.....121
		Instrument panel switches....121
		Knobs.....116,118
		Light wires & sockets.....120
		Panels, bezels, grilles & parts.....120,121
		Radio panels & block off.....120
		Screw kit (1932).....120
		Trim parts.....120
		Wiring harness.....120,132,133
		Decals149,150
		Air cleaner decal.....149
		Engine compartment decals.....150
		"Ford" oval decal.....150
		Interior decal.....150
		Deck (Trunk) Lid Parts70-73
		Disconnect Switches, Battery134
		Dimmer switch88,121
		Dip Stick, Oil33
		Distributor52,53
		Bushings.....52
		Caps, inner and outer.....52
		Coil.....54
		Condensers and parts.....52
		Contact points.....52
		E
		Emblems
		Deck lid.....70
		Grille.....59
		Hood.....59,60
		Emblems & Hood Ornaments59,60
		Emergency (Hand) Brake Parts13
		Engine Parts28-34
		Camshaft bearings & gears....31
		Camshaft bolts nuts & washers.....31
		Chrome nut covers.....30
		Complete gasket sets.....28
		Connecting rods & bearings...31
		Crankshaft gears, pulleys, ratchets & other parts.....32
		Dip stick tube & tube boss....33
		Engine enamel.....151
		Head gaskets.....28
		Head nuts & washers.....30
		Head studs.....30
		Engine & transmission support, rear.....29
		Front timing covers & pin.....30
		Fuel pump push rod bushing..47

JOE'S ANTIQUE AUTO 1932-1948 EARLY V-8 FORD PARTS

- Engine Parts (continued)**
- Gaskets, individual28,29
- Main bearings32
- Main bearing bolts, studs &
 nuts 32
- Motor mounts29
- Oil plug, rear30
- Oil pan drain plug & gasket32
- Oil pan ventilator tube33
- Oil pump parts34
- Paint151
- Pistons, rings, pins &
 clips30,31
- Rear main seal29
- Timing gears31
- Escutcheons**
- Door handle111
- Door lock112
- Spring111
- Quarter window111
- Vent window crank112
- Window crank105,106
- Exhaust Manifold Parts**30
- Stud, nut & washer30
- Gaskets29
- Exhaust System**26
- Accessory deflectors & pipe
 tips26
- Clamps & brackets26
- Crossover pipe26
- Muffler26
- Tail pipe26
- "Y" pipe26
- F**
- Fan & Hub Parts**41
- Fan Belts**41
- Fender Parts**65-67
- Boots (rear fender)67
- Braces65,66
- Brace panels & seals66
- Bolt & washer kits65
- Cowl to fender seals65
- Horn grille cover & pads66
- Inner apron panels &
 bumpers68
- Skirt rubber67
- Patch panels, (rear fender)66
- Rear frame horn covers18
- Support ties & brackets55
- Step pads (rumble)68
- Tie brackets55
- Trim & clip/bolt kits79
- Welting65
- Firewall**
- Body number ID & patent
 plates155
- Lacing kits62
- Firewall to cowl seal(1932)62
- Insulation135
- Rubber grommets138
- Flashers, Turn Signals**90
- Floorboard Parts**135-137
- Rubber plugs137
- Screw kits135
- Seals and seal plates136,137
- Transmission covers137
- Floor mats & Clips**137
- Flywheel Ring Gear & Parts**32
- Fog Lamps**156
- Frame & Body Mounting**18,139
- Frame repair sections139
- Inner apron to frame
 bumpers68

- Mounting pad kits19
- Rear frame horn covers18
- Webbing & anti squeak18
- Frame Rubber Bumpers**
- Front axle17
- Rear axle18
- Front Axle Parts**14-16
- Rubber bumpers18
- Perch nut15
- Radius rod rubber bushing
 & ball caps15
- Spindle bolts (king pin) &
 parts14
- Sway bar bushing & parts15
- Tie rod end, tube, and drag
 link14,15
- Front Brake Parts**9-13
- Front Door Molding**81
- Front License Plate Bracket**99
- Front Spring Parts**16,17
- Front Spring Shackles**17
- Front Wheel Cylinder**12
- Front Wheel Grease Seal**8
- Fuel Pump**47
- Mounting stand stud and
 gaskets47
- Push rods and bushing47
- Rebuild kits & parts47
- Fuel System**44-48
- Fuel lines & parts45
- Gauge air line & liquid45
- Gas tanks & parts44,45
- Float, sending unit45
- Sediment bowl & gasket47
- Sending unit, gas tank45
- Shut off valve44
- Fuse & Terminal Block
Assemblies**54
- G**
- Gas Caps**46
- Gas Tank**45
- Apron channel kit18
- Connection hoses & clamps45
- Door bumper & spring45
- Float, sending unit45
- Sending unit45
- Sending unit floor cover136
- Shut off valve44
- Tank filler rubber grommets46
- Tank mounting kits and
 pads44
- Gaskets**
- Carburetor48
- Distributor52
- Engine28,29
- Oil pan29
- Oil pan drain plug32
- Steering box21
- Transmission35,37
- U-joint24
- Water pump40
- Gearshift Knobs**35
- Gearshift Boots**35
- Generator Parts**50
- Bearings50
- Brush sets and springs50
- Cutout50
- Wiring133
- Glass Channels**131
- Glass & Window Patterns**143
- Glove Box Liners & Parts**121
- Grease Cap, Front Wheel**8
- Grease Seals, Wheels**8

- Grille & Parts**55-58
- Emblems & ornaments59,60
- Grille bar sets, mounting
 hardware & parts58
- Grille & hood side clips82,83
- Grille guard61
- Mounts55
- Pans55,56
- Rubber bumpers58
- Supports55
- Trim clip kits82, 83
- Trim & moldings57,58
- Vent panels (1940)57
- Grille Shell Ornaments &
Emblems**59,60
- Grommets, Rubber**
- Choke rod47,138
- Emergency brake &
 speedometer138
- Firewall138
- Hood pull cable138
- Radiator shell84
- Speedometer138
- Wiper arm to motor75
- Wiper hose138
- Wire loom138
- Ground Strap, Battery**134
- H**
- Hand Brake Parts**11,13
- Handles, Inside Door**110
- Handles, Outside Door**113
- Head Gaskets**28
- Headlights & Parts**84-88
- Aiming screws & springs86
- Bucket assemblies85
- Bulbs94
- Conduit kits88,92
- Dimmer switch88
- Gaskets86,87
- Glass lenses & parts87
- Halogen84,95
- Headlight bar & pads87
- Headlight to fender gasket86
- Inner ring84,86
- Shell & rim latch repair kits85
- Switch & horn rod parts23,88
- Sockets & wiring88
- Mounting bolts85
- Reflectors & parts86
- Reflector retainer rings86
- Rims84
- Stand pads87
- Wiring harness88
- Headliner Kits Pickup**124
- Heater Parts**123
- Defroster hose123
- Heater hose nipple123
- Hose clamps123
- Knobs123
- Water shut off valve123
- Wiring133
- Hinge Pins, Doors**105
- Hood Emblems &
Ornaments**59, 61
- Hood Parts**59-64
- Arm & spring supports64
- Brace parts64
- Bumpers63
- Catch lever & check64
- Center strip62,80
- Emblems59,60
- Handles & parts61,63
- Hinges, brackets & pads62,64
- Lacing kits62

- Latches & parts63
- Moldings80
- Ornaments & gaskets60,61
- Prop kit62
- Release handles & parts ...61,63
- Rods62
- Safety catch64
- Side panel clips63
- Trim80
- Horn**90
- Bell cover & projector90
- Button & parts21,23
- Button wiring21
- Grille cover & pads67
- Motor wiring132,133
- Mounting brackets90
- Relays90
- Rod23
- Screens90
- Hoses**
- Heater & defroster (air)123
- Radiator42
- Gas tank connection45
- House Clamps**
- Gas tank connection45
- Radiator hose42
- Water heater hose123
- Hub Bolts & Nuts, Wheel**8
- Hub Caps**7
- Hub Grease Cap, Front**8
- Hydraulic Brake Parts**10-13
- I**
- Ignition Parts**51-54
- Coils and coil adapters54
- Key blanks51
- Lock cylinder with keys51
- Lock assembly to dash pads ..23
- Points52
- Switch on-off plate51
- Switch body and parts51
- Wiring132,133
- Inner Apron, Front Fender**66
- Inside Door Handles &
Window Cranks**110,111
- Instrument Panel**120
- Insulation materials**135
- Intake Manifold (Valve Cover)
Parts**
- Gaskets28
- Washers29
- Interior Parts**
- Armrest kits105
- Headliner kits-pickup125
- Kick Panel Trim124
- Sun visors kits124
- Trim screw kits125
- K**
- Key Blanks**51
- Kick Panel Trim**124
- King Pin (Spindle Bolt) Parts**14
- Knobs**
- Cowl vent119
- Dash116-118
- Gearshift35
- Radio115
- L**
- Lacing Kits, Radiator & Cowl**62
- Latch, Door**108
- Latch, Trunk/Rumble Lid**71
- License Plate Brackets**99
- Front99
- Rear99

JOE'S ANTIQUE AUTO 1932-1948 EARLY V-8 FORD PARTS

<p>License Plate Frames 99</p> <p>License Plate Light Lenses, gaskets & parts 72,92 Wiring 132,133</p> <p>Light Bulbs 94,95</p> <p>Light & Horn Rod & Parts 23</p> <p style="text-align: center;">M</p> <p>Maintenance Books 148,149</p> <p>Manifold Parts, Exhaust Gaskets 29 Stud, nut & washer 30</p> <p>Manifold Parts, Intake Gaskets 29 Washers 30</p> <p>Manual, Operator's 147,148</p> <p>Manual, Repair & Service 148</p> <p>Master Cylinder & Parts 12</p> <p>Mechanical Brake Parts 9,10</p> <p>Metal Glass Channels 131</p> <p>Mirrors, Inside 77</p> <p>Mirrors, Outside 78,79 Hinge pin 78 Peep (Door edge) 79 Post mirrors 78 Wind wing 79</p> <p>Moldings & Trim 80,81 Cowl 80 Fender 81 Front & rear door 81 Hood 80 Rear quarter 81 Running board 81 Trim clip & bolt kits 82,83</p> <p>Motor Mounts 29</p> <p>Mufflers & Exhaust System 26</p> <p>Nut Covers, Chrome 30</p> <p style="text-align: center;">O</p> <p>Oil Related 600 W 151 Dipstick 33 Filler cap (breather) 33 Filter element 33 Pan drain plug & gasket 32 Pan gasket set 29 Pressure sending unit 32 Pump & rebuild kits 34</p> <p>Operator's Manuals 147,148</p> <p>Ornaments, Hood & Grille 58-60</p> <p>Outside Door Handles 113</p> <p style="text-align: center;">P</p> <p>Paint, Engine 151 Green & Blue engine enamel 155</p> <p>Parking Lights 89 Lenses, gaskets & bezels 89 Pads & boots 89 Repair kits & wiring 89 Turn signal lights 89</p> <p>Patch Panels Rear fender 66</p> <p>Patent Plates 151</p> <p>Peep Mirrors 79</p> <p>Pedals, Clutch & Brake 14</p>	<p>Pickup Parts 140-142 Bed assemblies 140 Bed parts 140,142 Bed mounting bolts 141 Bed rivet kits 141 Bed sheet metal 140-141 Headliner kits 124 Wood, bed & cab mounting .. 142</p> <p>Pilot Bearing 38</p> <p>Pistons & Parts 30,31</p> <p>Points, Ignition 52</p> <p>Posters, Early V-8 147</p> <p>Pressure Plate, Clutch 38</p> <p style="text-align: center;">Q</p> <p>Quarter Window Crank handles & escutcheons 112 Glass channels 131 Seals 126,127</p> <p style="text-align: center;">R</p> <p>Radiator - 1940 43</p> <p>Radiator Caps 43</p> <p>Radiator & Grille Parts 55-58 Air deflector 55 Caps 43 Drain cocks 43 Emblems 59 Fender support brackets 55 Greyhound caps 43 Grille pans 56 Grille plates 55 Hoses and clamps 42 Shell lacing kits 62 Mounting kits 43 Ornaments & gaskets 59-61 Overflow tanks 43 Radiator shell & parts 56 Shroud seal 55 Splash shield and mounting kit (1932) 56 Support rods and firewall brackets 43 Trim 56 Upper grille support 55 Upper radiator panels 55</p> <p>Radio Parts 114-115 Antenna hole plugs 115 Books 153 Change buttons 114 Knobs 114-115 Panels & block off 114,120 Selector knobs 114 Speaker grille 120 Speaker boot 115</p> <p>Rear Axle 24 600W gear lubricant 155 Bearings & races 24 Hub key 9 Rubber bumpers 18 Drive pinion bearings, locknut & washer 24 Gaskets 24 Housing repair sleeve 24 Torque tube gasket 24 Universal joint gaskets 24</p> <p>Rear Door Molding 78</p> <p>Rear Emergency Brake Cable 13</p> <p>Rear Engine Support 29</p> <p>Rear Fender Patch Panel 66</p> <p>Rear Spring Shackles 17</p> <p>Rear Spring Parts 16,17</p> <p>Rear View Mirror, Inside 77</p> <p>Rear Wheel Cylinder 12</p>	<p>Rear Wheel Grease Seal 9</p> <p>Back (Rear) Window Parts Bumpers 100 Glass channel 131 Roll down channel kit 130 Regulator 109 Regulator Handles 109 Seals 126</p> <p>Regulators, Window 109</p> <p>Repair & Service Manuals 148</p> <p>Resistors & Circuit Breakers 54</p> <p>Restoration Items 151,152 600 weight oil 151 Cage nuts 151 Clinch nuts 151 Engine Enamel 151 Insulation materials 135 Spike brush 152 Weather strip adhesive 104 Wood finish buttons 152</p> <p>Ring Gear, Flywheel 32</p> <p>Rings, Pistons 30</p> <p>Rocker Panels 142</p> <p>Roof/Top Seal 100</p> <p>Rotor, Distributor 52</p> <p>Rumble/Deck Lid Parts 70,71 Deck lid rubber bumpers & brackets 70,71 Emblems 72 Grab handles 70 Hinge kits 70 Latches & parts 70,71 Locking handles & pads 70 Rubber seals 73 Seat clips & hangars 70 Step pads 70 Striker plates 71</p> <p>Running Boards 69 Bolt kits & grommets 69 Braces 69 Cover kits & cement 69 Trim 81</p> <p style="text-align: center;">S</p> <p>Sales Brochures 149,150</p> <p>Seals, Rubber Convertible window 127 Door 104 Door glass 127 Floorboard 137 Glass setting tape 126 Quarter window 126,127 Radiator shroud 55 Rear (back) window 126 Tailgate & back window Seals (wagon) 73 Upper door 104 Vent window 127 Windshield 127</p> <p>Seat Parts 125</p> <p>Service & Repair Manual 148</p> <p>Service Bulletins 147</p> <p>Service Brake & Parts 13</p> <p>Sending Unit, Gas Tank 45</p> <p>Sending Unit, Temperature 42</p> <p>Sending Unit, Oil Pressure 32</p> <p>Shell, Radiator 56</p> <p>Shell Lacing, Radiator 62</p> <p>Scuff Plates, Door 103</p> <p>Shackles, Spring 17</p>	<p>Sheet Metal Clinch & cage nuts 151 Front fender inner apron panel 68 Grille pans & plates 55,56 Pickup cab & bed parts .. 140-141 Radiator pans & splash shields 55,56 Rear fender patch panels 66 Front & rear gravel deflector .. 98 Steering tube/pedal plates ... 136 Transmission floor covers 137</p> <p>Shock Absorber Parts Shock links 16 Bushings 16 Track bar & shock bushings... 15</p> <p>Shop Manual 147-149</p> <p>Sill Plates, Door 103</p> <p>Solenoid, Starter 51</p> <p>Solenoid Cables 134</p> <p>Spare Tire Hold Bracket 7</p> <p>Spark Plugs & Wires 54</p> <p>Speedometer Cables 39</p> <p>Speedometer Gear Case Parts 39</p> <p>Spindle Bolt Kits & Parts 14</p> <p>Spreader Bars 18</p> <p>Springs Parts, Front & Rear 16,17 Axle rubber bumper 18 Center bolt 16 Liners 16 Pads 16 Shackles & parts 17 U-clamps 16</p> <p>Starters & Parts 50 Buttons 51 Cable brackets & grommet... 134 Drive & parts 50 Solenoid 51 Floor switches 51 Ignition switch on-off plate..... 51</p> <p>Steering 20-22 Column upper bushing 21 Gaskets, seals & shims 21 Horn button & parts 21,22 Sector shaft 20 Steering box bearings & races 21 Steering box parts 21 Steering wheels 22 Steering wheel nut & key & ... 21 Worm gear 20</p> <p>Steering Wheels 22</p> <p>Stop Light Switch 12</p> <p>Sun Visor Kits 124</p> <p style="text-align: center;">T</p> <p>Tappets and Valves 33</p> <p>Tailgate (Pickup) 140 Miscellaneous parts 140</p> <p>Tailgate (Station Wagon) Locking handle 70 Rubber Bumpers 107 Window & Tailgate rubber seals 73</p> <p>Taillights & Parts 91-93 Bulbs 84 Brackets & braces 93 Gaskets 93 Glass lens 91</p>
---	--	--	---

HUB CAPS 1932-1936 (Non painted insignias*)

B-1130-A	4-cylinder, stainless steel, FORD embossed	32-33	23.00 ea
18-1130	Stainless steel, V8 embossed	1932	23.00 ea
40-1130-A	Stainless steel, V8 embossed	1933	23.00 ea
40-1130-C	Stainless steel, FORD embossed	1934	23.00 ea
40-1130-B	Stainless steel, V8 embossed	1934	23.00 ea
48-1130	Stainless steel, V8 embossed	1935	23.00 ea

* Note: Above hubcaps are also available with painted insignias as original for \$33.00 each, add -P to part number
 68-1130 Black w/stainless steel center,
 also fits 1937-1939 wheels.....1936 60.00 ea
 68-1034 Wheel spider clips to secure 1936-39
 hub caps, set of 5 clips with rivets.....36-39 24.00 set



HUB CAPS 1940-1948 FORD (ORIGINAL)

01A-1130	Stainless steel, Deluxe car.....	1940	25.00 ea
01C-1130	Stainless steel, standard & pickup	1940	25.00 ea
11A-1130	Stainless steel, car & 41-42 P/U ..	1941	25.00 ea
21A-1130	Stainless steel, 42 car & 46 P/U...	1942	25.00 ea
51A-1130	Stainless steel, car	1946	25.00 ea
6A-1130	Stainless steel, car & 47-56 P/U ..	47-48	25.00 ea



* Note: Above hubcaps are also available with painted insignias as original for \$40.00 each, add -P to part number

HUB CAPS 1940-1948 MERCURY (ORIGINAL)

29A-1130	Stainless steel.....	1942	65.00 ea
59A-1130	Stainless steel.....	1946	65.00 ea
C59A-1130	Stainless steel Monarch "Canadian Lion"	46-48	65.00 ea
6M-1130	Stainless steel.....	47-48	65.00 ea
29AS-1130	Stainless steel, Smooth	42-48	50.00 ea

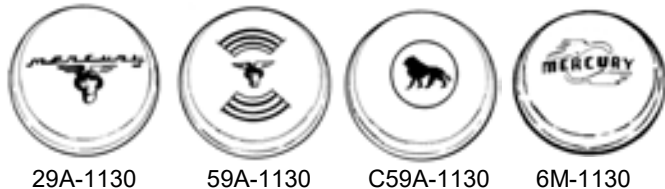

TRIM RINGS – STAINLESS STEEL

01A-18303-14	14", Outer ring, ribbed	25.00 ea
01A-18303-15	15", Outer ring, ribbed	30.00 ea
01A-18303-16	16", Outer ring ribbed	35-48 30.00 ea
6A-18303-14	14", Outer ring, smooth	25.00 ea
6A-18303-15	15", Outer ring, smooth	30.00 ea
6A-18303-16	16", Outer ring smooth	35-48 30.00 ea
01A-18331	16", Inner ring for vented Ford wheels	40-41 55.00 ea



Outer trim ring 01A-18331

SPARE TIRE TRIM RINGS AND SEALS

40-1350	Tire cover trim ring, stainless steel, 17" tire	33-34	95.00 ea
48-1350	Tire cover trim ring, stainless steel, 16" tire	35-36	95.00 ea
40-1351	Spare tire rubber cover seal 1933-1936 passenger, 1932-1948 wagon and 1941-1951 Mercury wagon	33-51	8.00 ea
68-1351	Spare tire lock ring seal, this is the inner lock ring seal	1936	10.00 ea

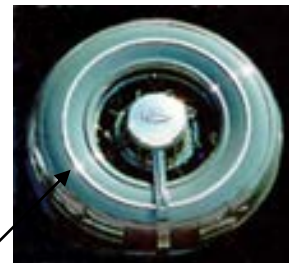

40-1350 / 48-1350

SPARE TIRE COVERS WITH "FORD" SCRIPT

B-1395VB18	17" or 18" black vinyl	32-34	50.00 ea
B-1395VT18	17" or 18" tan vinyl	32-34	50.00 ea
B-1395VB16	16" black vinyl	35-48	50.00 ea
B-1395VT16	16" tan vinyl	35-48	50.00 ea

SPARE TIRE HOLD DOWN AND MOUNT PARTS

B-1410-G	Grommet for side mount arm.....	1932	3.00 ea
B-1430-E	Hardware kit for side mount arm, Early 1932 only	1932	25.00 kit
B-1430-L	Hardware kit for side mount arm, late 1932 and 1933-1934 comm ..	32-34	25.00 kit
78-1492	Tudor, Fordor, Club Coupe, Club Cabriolet, Phaeton, Convertible Sedan & 1939 Conv. Sedan	37-38	60.00 ea
21A-1492	Convertibles Only	42-48	60.00 ea



78-1492 21A-1492

TIRES

Listed below are our most popular tires for 1932-1948 Ford cars and trucks. In addition to these we can supply any other make and size for other years, please call for pricing. Firestone is well known for being a name brand tire originally used on many Fords. We also offer Lester tires as another excellent quality tire at a slightly lower cost. NOTE: PRICES SHOWN ARE AS OF APRIL 2019

18" BLACKWALL TIRE

550-18-BF	550 x 18" Firestone	1932	185.00 ea
550-18-BL	525/550 Lester	1932	165.00 ea

18" WHITEWALL TIRE

550-18-WF	550 x 18" Firestone, 3 1/4" whitewall	1932	226.00 ea
550-18-WL	525/550 x 18 Lester, 3 1/4" whitewall	1932	198.00 ea

17" BLACKWALL TIRE

550-17-BF	525/550 x 17" Firestone	33-34	176.00 ea
550-17-BL	525/550 x 17" Lester	33-34	163.00 ea

17" WHITEWALL TIRE

550-17-WF	525/550 x 17" Firestone, 3" whitewall	33-34	236.00 ea
550-17-WL	525/550 x 17 Lester, 3 3/4" whitewall	33-34	199.00 ea

16" BLACKWALL TIRE

600-16-BF	600 x 16" Firestone	35-48	185.00 ea
650-16-BF	650 x 16" Firestone	35-48	198.00 ea
600-16-BL	600 x 16" Lester	35-48	165.00 ea
600-16-BS	600 x 16" with "FORD" script	35-48	ASK

16" WHITEWALL TIRE

600-16-WF	600 x 16" Firestone, 3 1/4" whitewall	35-48	221.00 ea
650-16-WF	650 x 16" Firestone, 4" whitewall	35-48	230.00 ea
600-16-WL	600 x 16" Lester, 3 7/8" whitewall	35-48	192.00 ea
600-16-WS	600 x 16" with "FORD" script, 3 1/2" whitewall	35-48	ASK
600-16-DW	600 x 16 Firestone, 3 1/4" double whitewall	35-48	ASK
600-16-DWS	600 x 16" with "FORD" script, 3 1/2" double whitewall	35-48	ASK

Not all tires are stocked, non-stocked tires may be drop shipped from the factory. Please call for shipping costs.



INNER TUBES, VALVE STEM CAPS & RIM LINERS

17-18 Tube	Inner tube for 17" & 18" tires **	32-34	25.00 ea
16 Tube	Inner tube for 16" tires **	35-48	25.00 ea
B-1705	Metal valve stem cap	37-41	.75 ea
17-21 RL	Rim liners for 17"-21" wheels	26-34	3.50 ea

**The above tubes have rubber stems. Metal stem tubes & hardware also available. Please call for pricing.

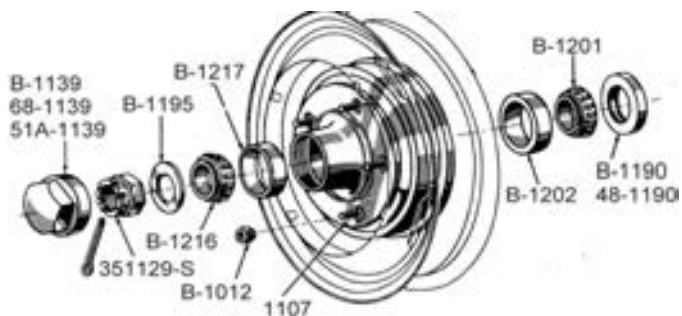

FRONT WHEEL PARTS

B-1012	Wheel nut, cars & pickups	32-48	.50 ea
A1012-WS	Wheel nut washer, stainless steel	32-48	.50 ea
B-1195	Front hub grease retainer washer cars & pickups	32-48	2.75 ea
351125-S	Castle nut for spindle .812 thick	32-35	3.50 ea
351129-S	Castle nut for spindle .687 thick	36-48	3.50 ea

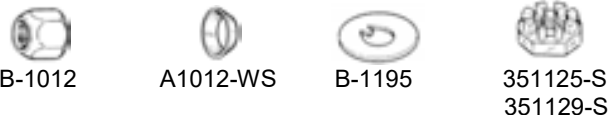

FRONT WHEEL GREASE RETAINER / SEALS

B-1190	Retainer (slinger style)	28-34	6.00 ea
48-1190	Seal, 2.68" OD	35-48	3.50 ea



FRONT HUB GREASE CAPS

B-1139	Cars & pickups, (1 1/2" tall)	32-34	ASK
68-1139	Threaded cap, (1 1/4" tall)	35-48	6.50 ea
51A-1139	Press-on cap	40-54	5.00 ea

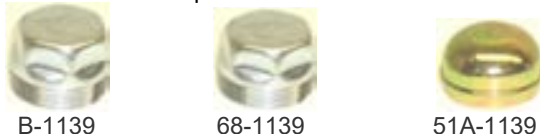

FRONT WHEEL BEARINGS & RACES

B-1201	Front inner bearing	32-48	19.00 ea
B-1202	Front inner race (cup)	32-48	12.00 ea
B-1216	Front outer bearing	28-48	22.00 ea
B-1217	Front outer race (cup)	28-48	10.00 ea
B-1201-17-S	Set including 1 of each of above	28-48	60.00 set

Bearings & races for big trucks also available, please ask!

HUB BOLTS (CARS & 1/2 TON COMMERCIAL)

	A	B	C	D		
B-1107	1.44	1.19	.38	.62	32-35	2.00 ea
68-1107	1.56	1.36	.58	.56	36-48	4.00 ea
21A-1107 *	1.93	1.75	.62	.56		3.00 ea
01A-1107-C	1.48	1.28	.51	.62	41-47	1.50 ea
51A-1107	1.52	1.26	.47	.62	46-48	4.00 ea
51A-1107-R**	1.52	1.26	.47	.62		3.50 ea

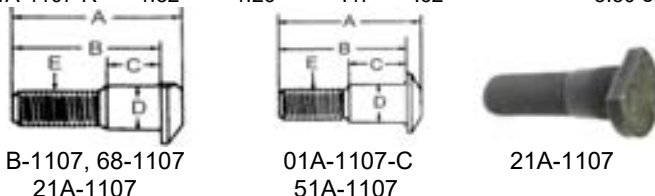

* Use with 21A-1125 brake drum D dia has straight knurls
** Use with 51A-1125 brake drum "D" dia has straight knurls



91A-1127

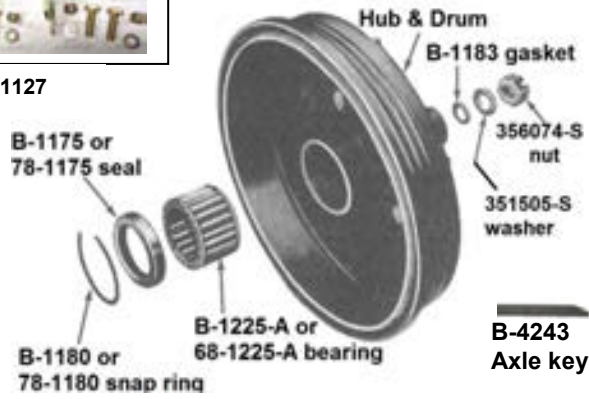

REAR WHEEL HUB PARTS

B-4235-SH	Rear axle tapered shim, for worn axle.....	32-48	2.00 pr
B-4243	Rear axle key	32-48	1.00 ea
356074-S	Rear axle nut, 5/8-18 thread	28-48	2.00 ea
351505-S	Rear axle steel washer	28-48	1.50 pr
B-1183	Rear wheel hub fiber gasket	28-48	.75 ea

REAR BRAKE DRUM RETAINER KIT

Safety item to prevent the loss of brake drum & axle stub in the event of snapping the axle

91A-1127	Brake drum retainer kit.....	39-48	31.50 kit
----------	------------------------------	-------	-----------

REAR WHEEL GREASE SEALS

B-1175	Cars & pickups, 3.18" OD	32-38	3.25 ea
78-1175	Cars & pickups, 2.84" OD	38-48	3.75 ea

REAR WHEEL BEARING SNAP RINGS

B-1180	Cars & pickups 3-11/32" OD	32-38	2.50 ea
78-1180	Cars & pickups, 3" OD	38-48	2.25 ea

REAR WHEEL BEARINGS

B-1225-A	Rear roller bearing, 3.19" OD, 1-23/32" long.....	28-36	24.00 ea
68-1225-A	Rear roller bearing, 2.84" OD, 1-21/32" lg.....	36-48	29.00 ea

BRAKE DRUM & FRONT HUB

21A-1125	Front or rear brake drum, cars & pickup, where hub (not included) fits under/behind drum, 3-1/4" hub OD, cars & pickups.....	40-48	140.00 ea
01A-1104	Front wheel hub, for use with 21A-1125 brake drum, bearing races sold separately	40-48	110.00 ea
51A-1125	Front or rear brake drum, cars & pickup, where hub (not included or available) fits over outside drum, 4" hub OD.....	42-48	165.00 ea

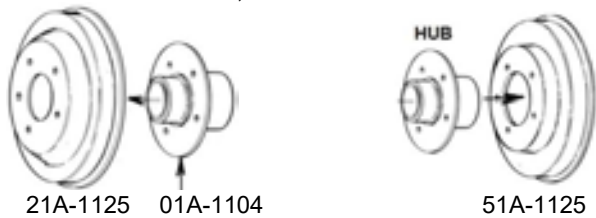

**WE OFFER WHEEL PULLERS!
SEE THE RESTORATION ITEMS IN BACK OF CATALOG**

Grease

Premium Timken brand grease with special additives to prevent wear and rust. 1 lb container. Part no GREASE \$6.50 each



BRAKE SHOE RETURN SPRING

B-2035	Upper, mechanical brakes	28-34	1.50 ea
B-2036	Lower, mechanical brakes	32-34	3.00 ea
48-2035	Upper, mechanical brakes	35-36	2.25 ea
91A-2035	Hydraulic brakes.....	39-48	2.25 ea

MISC. MECHANICAL BRAKE PARTS - WHEEL AREA

B-2023	Brake shoe roller	28-34	1.25 ea
B-2045	Brake shoe roller pin.....	28-34	1.00 ea
B-2041	Brake adjusting wedge	32-36	14.00 ea
78-2041	Brake adjusting wedge	37-38	7.00 ea
A-2041-C	Wedge dust cap.....	28-36	1.50 ea
A-2042	Brake link.....	32-34	6.00 ea
48-2042	Brake link	35-36	7.00 ea
68-2042	Brake link	36-37	7.00 ea
78-2042	Brake link	37-38	ASK
B-2050	Front brake operating wedge	32-34	14.00 ea
B-2051	Front brake operating wedge stud	32-34	10.00 ea
48-2078	Front brake operating pin housing	35-36	14.00 ea
B-2082	Front brake shaft bushing, also fits 1932-1935 trucks	32-36	2.00 ea
B-2087	Front brake lever dust ring.....	32-36	.50 ea
B-2227	Rear brake camshaft bushing, graphited (2 pieces).....	32-36	5.00 pr
B-2230	Rear brake cam, all body styles....	32-34	9.00 ea
B-2231-A	Rear brake camshaft	32-34	19.00 ea
B-2234-S	Rear brake camshaft dust ring.....	32-36	2.00 ea

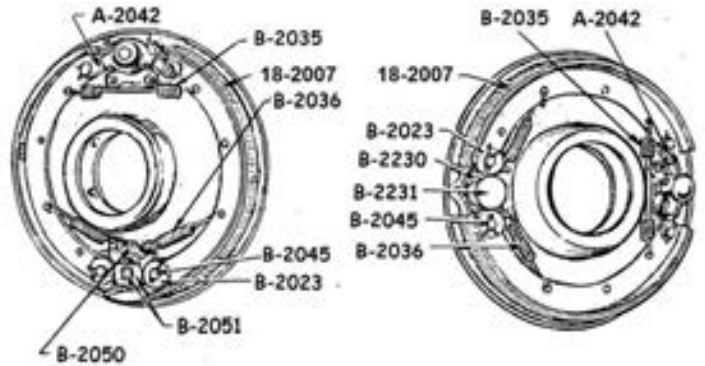

1933-1934 Brake System

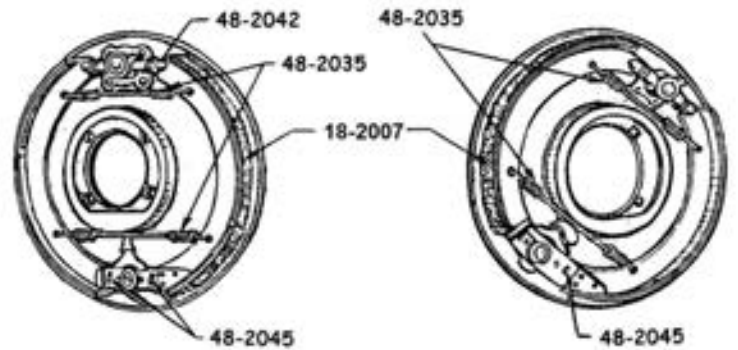

1935-1936 Brake System

SERVICE BRAKE RODS & CABLES

78-2494	Front brake cable, 61-3/4"	37-38	26.50 ea
78-2498	Rear brake cable, 66-3/4"	37-38	26.50 ea
18-2499	Rear brake rod, passenger and commercial, 56-1/2"	1932	ASK
48-2499	Rear brake rod, passenger and commercial, 75-1/2"	35-36	ASK

BRAKE ROD SUPPORTS

B-2502	Front brake rod support	32-34	ASK
48-2502	Front brake rod support	35-36	6.75ea
B-2503	Rear brake rod support	32-34	9.75 ea
48-2503	Rear brake rod support	35-36	9.75 ea



BRAKE ROD ADJUSTING CLEVIS & PINS

A-2461	Brake rod adjusting clevis, fork type	32-36	3.00 ea
A-2466	Brake rod adjusting clevis, fisheye type	32-36	6.00 ea
B-2460	Clevis pin for brake rod, 5/16" diameter	32-38	.75 ea



BRAKE LININGS -- MECHANICAL BRAKES

Sets below are enough for 4 wheels (8 pieces).

18-2007-M	Molded lining set, includes rivets ..	32-34	ASK
18-2007-W	Woven lining set, includes rivets ..	32-34	85.00 set
78-2007-M	Molded lining set, includes rivets ..	35-38	ASK
78-2007-W	Woven lining set, includes rivets ..	35-38	110.00 set
B-2018	Rivets, spare set of 20	32-38	1.25 set

Linings riveted on your shoes for an additional charge of \$70.00 for 2 wheels, Please call for lead time.

BRAKE SHOE RIVET TOOL

A-2018	Used with mechanical or hydraulic brakes	32-48	26.00 ea
--------	--	-------	----------



HYDRAULIC BRAKE ADAPTER SET

X-2000	Hydraulic brake adapter set, adapts 39-48 backing plates to 28-36 spindles w/2 bearing spacers and 2 backing plate spacer rings	28-38	18.00 set
--------	---	-------	-----------

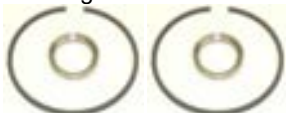

BRAKE LININGS & SHOES - HYDRAULIC BRAKES

91A-2007-M	Molded lining set with rivets, for 4 wheels (8 pieces)	39-48	50.00 set
91A-2007-W	Woven lining set with rivets, for 4 wheels (8 pieces)	39-48	98.00 set
B2018	Rivets, spare set of 20	32-48	1.25 set



Linings riveted on your shoes for an additional charge of \$70.00 for 2 wheels. Call for lead time.

01A-2001	New shoes with bonded linings for 2 wheels (4 pieces)	39-42	60.00 set
51A-2001	New shoes with bonded linings for 2 wheels (4 pieces)	46-48	60.00 set



01A-2001



51A-2001

BRAKE SHOE ANCHOR PINS & PLATE BARS

78-2027-B	Brake shoe anchor pin	37-38	4.00 ea
91A-2027	Brake shoe anchor pin	39-45	10.00 ea
91A-2028	Brake shoe cam	39-45	4.50 ea
51A-2028	Brake shoe cam	46-48	4.50 ea
91A-2030	Anchor pin plate	39-45	3.50 ea
51A-2030	Anchor pin plate, 46-47 pickup	46-48	5.00 ea

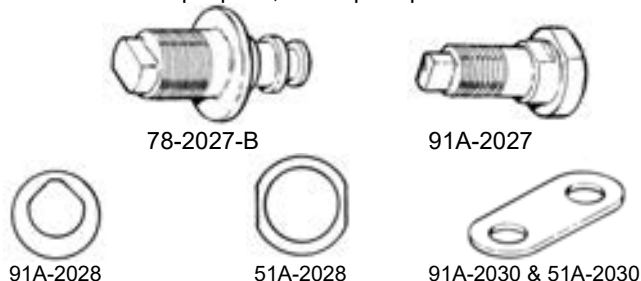

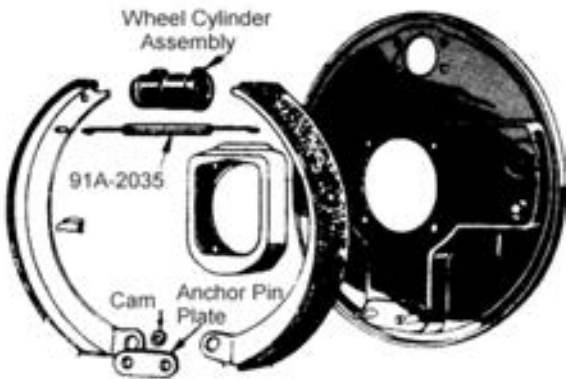

FRONT BACKING PLATE COMPONENTS

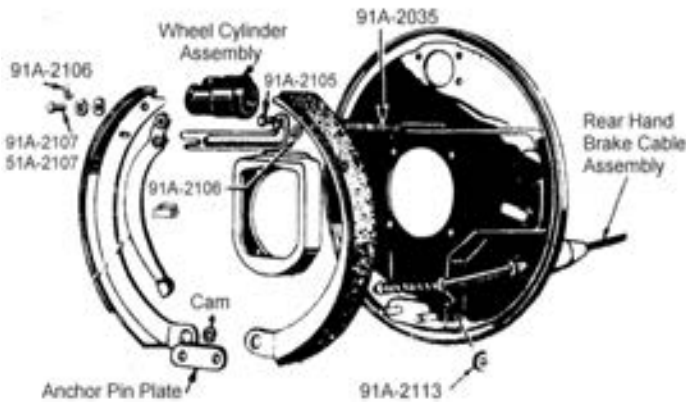

REAR BACKING PLATE COMPONENTS

FRONT BRAKE HOSE BRACKETS

- 91A-2082 Stamped steel, car & pickup 39-41 25.00 pr
- 21A-2082 Stamped steel, car & pickup 42-48 25.00 pr

BRAKE SHOE RETURN SPRING

- 91A-2035 Hydraulic brakes..... 39-48 2.25 ea



91A-2035

BRAKE SHOE RETAINER CLIP

- 51A-2125 1946-1948 passenger & 1946-1947 1/2 & 3/4 ton pickup..... 46-48 5.75 ea



51A-2125

HAND BRAKE PINS & CLIP (WHEEL AREA)

- 91A-2105 Hand brake link pin, passenger and commercial 39-45 2.75 ea
- 91A-2106 Hand brake U-clip retainer 39-48 .75 ea
- 91A-2107 Hand brake lever pin .710" long... 39-45 2.75 ea
- 51A-2107 Hand brake lever pin .853" long... 46-48 N/A
- 91A-2105-K Hand brake pin kit including (2) 51A-2107, (2) 91A-2105 & (4) 91A-2106..... 39-48 11.00 ea



91A-2105



91A-2106



51A-2107



91A-2107

HAND BRAKE EQUALIZER PARTS

- 11A-2091 Hand brake equalizer rubber bushing, passenger 41-48 5.00 ea
- 91A-2119 Hand brake equalizer 39-48 4.00 ea
- 48-2045 Hand brake equalizer pin..... 39-48 1.00 ea
- A-2466 Clevis..... 28-48 6.00 ea



11A-2091



91A-2119



48-2045



A-2466



91A-2082 21A-2082
Front Brake Hose Brackets

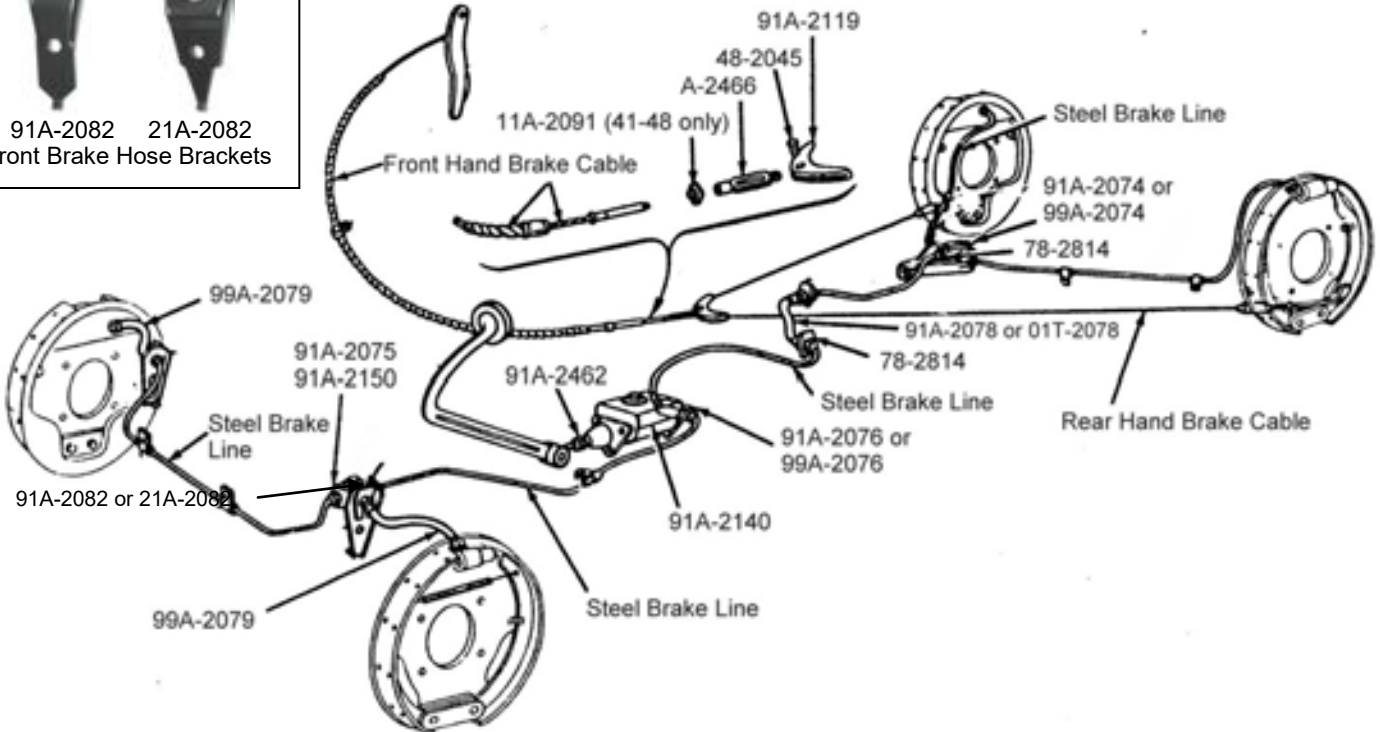

MASTER BRAKE CYLINDER & RELATED PARTS

91A-2140	Master cylinder, 39-48 car & 39-52 1/2 ton pickup	39-48	70.00 ea
91T-2140	Master cylinder 1 & 2 ton truck.....	39-48	80.00 ea



91A-2140

91T-2140

91A-2004	Master cylinder rebuilding kit, 39-48 cars & 1939-52 pickups	39-48	15.00 kit
91T-2004	Master cylinder rebuilding kit, 1 & 2 ton trucks	39-47	17.00 kit



91A-2004

91A-2143	Master cylinder push rod 39-48 cars & 1939-52 pickups	39-48	13.00 ea
91T-2143	Master cylinder push rod 1 & 2 ton trucks	39-47	13.75 kit
91A-2162	Master cylinder cap	39-48	15.00 ea
91A-2167	Master cylinder cap gasket	39-48	1.25 ea
91A-2180	Master cylinder rubber boot included with 91A-2140, 91A-2004 & 91T-2004.....	39-48	2.50 ea
91A-2076	Master cylinder outlet connector, V type, 2 outlets	39-40	13.75 ea
99A-2076	Master cylinder outlet connector, straight type, 2 outlets	39-48	10.00 ea
91T-2076	Master cylinder outlet connector, V type with 3 outlets, pickups.....	42-52	13.00 ea
91A-2077-A	Master cylinder outlet fitting bolt	39-48	5.50 ea
91A-2151	Copper gasket, .61 ID x .81 OD ...	39-48	.75 ea
91A-2152	Copper O-ring, .51 ID x .81 OD.....	39-48	.75 ea



91A-2462	Brake pedal to master cylinder rod ..	39-48	7.00 ea
----------	---------------------------------------	-------	---------

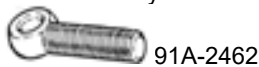

91A-7011136	Master cylinder cover plate, car & 1948-1952 pickup	39-48	6.00 ea
-------------	---	-------	---------



91A-7011136

WHEEL CYLINDERS

1939-1941 Front wheel cylinders are discontinued. Order the following 1942-1948 cylinders that fit 1939-1941. Cylinders must be used in pairs due to piston size change. Bleeder screw included.

1939-1948 Cars & 1939-47 1/2 Ton Pickups			
21A-2061	Right front, 1" x 1 3/8" bore	42-48	39.00 ea
21A-2062	Left front, 1" x 1 3/8" bore	42-48	39.00 ea
91A-2261	Right rear, 1" x 1 1/8" bore	39-48	39.00 ea
91A-2262	Left rear, 1" x 1 1/8" bore	39-48	39.00 ea

1939-1947 3/4 Ton Trucks, 122" Wheelbase			
21A-2061	Right front, 1" x 1 3/8" bore	42-47	39.00 ea
21A-2062	Left front, 1" x 1 3/8" bore	42-47	39.00 ea
21A-2061	Right rear, 1" x 1 3/8" bore	39-47	39.00 ea
21A-2062	Left rear, 1" x 1 3/8" bore	39-47	39.00 ea

1939-1947 1 Ton Trucks, 122" Wheelbase			
21A-2061	Right front, 1" x 1 3/8" bore	42-47	39.00 ea
21A-2062	Left front, 1" x 1 3/8" bore	42-47	39.00 ea
92Y-2261	Right & left rear, 1 3/8" bore	39-47	56.00 ea

1939-1947 1 1/2 Ton Trucks			
92Y-2261	Right & left front, 1 3/8" bore	39-47	56.00 ea
91T-2261	Right & left rear, 1 1/2" bore	39-47	70.00 ea



Wheel Cylinder



Wheel cylinder rebuild kit



8M-2208

WHEEL CYLINDER REBUILD KITS / BLEEDER SCREW

Each kit does one wheel and includes boots & cups. Available either with or without compression spring.

91A-2221-NS	Front kit, 1 1/4" no spring *	39-41	ASK
91A-2221	Front kit, 1 1/4" includes spring *	39-41	11.00 kit
* Above kits for original 1939-41 wheel cylinders			
21A-2221-NS	Front kit, 1 3/8" no spring	42-48	ASK
21A-2221	Front kit, 1 3/8" includes spring... ..	42-48	17.00 kit
91A-2128-NS	Rear kit, 1 1/8" no spring	39-48	ASK
91A-2128	Rear kit, 1 1/8" includes spring	39-48	10.00 kit
8M-2208	Wheel cylinder bleeder screw	39-48	1.25 ea

1939-47 1 & 1 1/2 Ton Trucks			
91T-2221	1 Ton rear, 1 1/2 ton front 1 3/8" ..	39-47	13.00 kit
91T-2128	1 1/2 ton rear, 1 1/2"	39-47	15.00 kit

MASTER BRAKE & WHEEL CYLINDER KITS

Buy kit and save. Kits include Master cylinder, (2) front and (2) rear wheel cylinders, (2) front brake hoses, (1) rear brake hose and (4) brake shoe retracting springs.

91A-2140-KIT	Car & pickup	39-48	230.00 kit
--------------	--------------------	-------	------------



STOP LIGHT SWITCH

BB-13480	1934 Pickups, 1929-1931 all	29-34	7.75 ea
48-13480	Cars & pickups	35-38	16.00 ea
11A-13480	Located behind master cylinder...	39-48	7.00 ea



BB-13480



48-13480



11A-13480

BRAKE LINE CONNECTORS & PARTS

91A-2074	Brass rear connector tee.....	39-41	11.00 ea
99A-2074	Brass rear connector, tee, cars.....	41-48	13.75 ea
91A-2075	Brass connector, front.....	39-48	9.75 ea
91A-2150	Front brake line connecting bolt, fits through 91A-2075	39-48	6.25 ea
91A-2149	Copper O-ring gasket, with front brake hose 99A-2079, and 91A-2075 brake line connector .45 ID x .69 OD	39-48	.75 ea

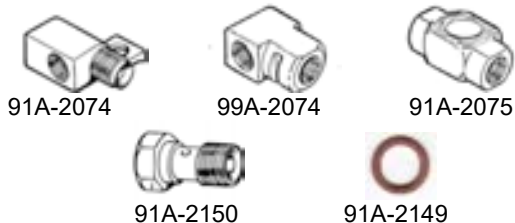

BRAKE HOSE & BRAKE CABLE RETAINER CLIP

78-2814	Retainer clip.....	39-48	1.50 ea
---------	--------------------	-------	---------

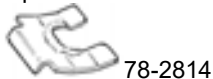

HYDRAULIC BRAKE HOSES

99A-2079	Front hose, 15 3/4' long, 2 req'd, all cars & trucks.....	39-48	14.00 ea
91A-2078	Rear hose, 8 3/4" long, 39-48 cars and 39-41 trucks	39-48	12.00 ea
01T-2078	Rear hose, 18 3/4" long, 42-47 trucks	42-47	16.50 ea

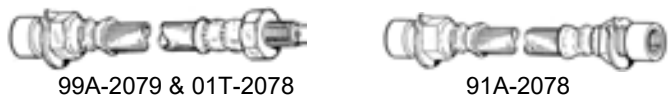

BRAKE LINE CLIPS

91A-2244-K	Brake line clip kit, original style, 14 clips with mounting bolts	39-48	18.50 kit
------------	---	-------	-----------

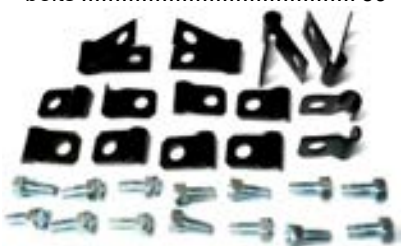

91A-2244-K

HAND BRAKE STABILIZER BRACKETS & GROMMETS

91A-2271	Hand brake stabilizer, pair	39-40	5.00 pr
91A-2272	Emergency cable guide bracket, Pair, for rear cable.....	39-40	6.00 pr
91A-2273	Cable grommet at frame, for front cable	39-40	2.50 ea



FRONT HAND BRAKE CABLES

78-2853-A	60" long, cars.....	37-38	29.00 ea
01C-2853	70" long, cars & 39-41 pickups * ..	1939	29.00 ea
01A-2853	77" long, cars *	1940	29.00 ea
11A-2853	87.5" long, cars *	41-48	29.00 ea
21C-2853	103.5" long, pickups	42-47	29.00 ea

*These cables also available in top quality by Bob Drake for \$55 each, add -D after part number



01A-2853, 01C-2853 & 11A-2853

01A-17264	Speedometer & Brake cable clip 1940-48 car	40-48	2.50
-----------	---	-------	------



01A-17264

REAR HAND BRAKE CABLES & BOOTS

91A-2275-B	Cars & pickups, 122" *	39-41	16.00 ea
21A-2275	Cars, 107.25" *	42-48	16.00 ea
21C-2275	Pickups, 46" (2 req'd.)	42-47	28.50 ea
91A-2597	Cable boot only.....	39-48	4.00 ea
91A-2113	Cable spring plate.....	39-48	2.50 ea

*Includes 91A-2597 cable boots



91A-2275 & 21A-2275



91A-2597



91A-2113

HAND BRAKE PARTS (HANDLE AREA)

91A-2786	Brake lever pawl	39-48	10.00ea
B-2788	Hand brake lever sleeve.....	32-34	2.00 ea
91A-2790	Brake sector	39-42	8.00 ea
91A-2788	Hand brake lever pawl spring 1939-42 car \$ 1939-42 pickup	39-42	3.00 ea
51A-2788	Hand brake lever pawl spring, car	46-48	4.00 ea

EMERGENCY BRAKE HANDLE

A-2780-C	Chrome plated with ratchet	30-32	80.00 ea
40-2780	Chrome plated without ratchet ..	33-34	80.00 ea



40-2780

HAND BRAKE BOOTS

EB-7000-B	Black rubber	32-36	3.00 ea
EB-7000-T	Tan rubber	32-36	ASK
A-7001-EB	Accessory trim plate, polished stainless steel with screws	32-36	8.00 ea



EB-7000



A-7001-EB

CLUTCH & BRAKE PEDAL PADS

B-2454	Pyramid rubber design, w/FORD script on back, also 1933-1934 rumble step	1932	10.00 ea
40-2454	Pyramid rubber design, also 1935-1936 rumble step	33-36	8.50 ea
78-2454	Pyramid rubber design, also 1937-1939 rumble step	37-40	8.50 ea
11A-2454	Round ring design	41-48	8.50 ea
7RT-2454	Round ring design, 3 1/2" OD, for big trucks	48-56	10.00 ea
B-2454-OS	Pyramid rubber design with offset mounting stud, 1/2"-20 stud.....		19.50 ea

Note: Below pedal pads have pyramid rubber center design with stainless steel trim ring. Used for custom applications.

HB-2454-SS	Original tapered stud, also for 1933-1956 pickups.....	33-48	33.00 ea
HB-2454-SS-1	1/2" -20 stud with nut		33.00 ea
B-2454-A	1/2"-20 stud, adjustable flat mount.....		48.00 ea
B-2454-B	1/2"-20 stud, adjustable angle mount.....		48.00 ea

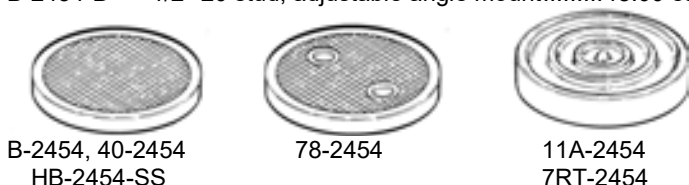

BRAKE PEDAL RETRACTING SPRINGS

B-2456	Brake pedal spring 3.12" long	1932	12.00 ea
48-2472	Brake rod return spring, 6.5" lg	35-36	4.50 ea
48-7523	Brake pedal spring, 3.44" long *	35-36	5.50 ea
78-2456	Brake pedal spring, 3" long	37-38	3.50 ea
91A-7523	Brake pedal spring, 5.4" long *	1939	2.50 ea
01A-2456	Brake pedal spring, 4" long	40-41	3.75 ea
99A-7523	Brake pedal spring, 7.6" long *	41-48	4.00 ea
01T-2472	1942-47 Pickups & 40-47 trucks ..		
	10.25" *	42-47	4.00 ea

* These springs also used for clutch pedal



BRAKE & CLUTCH PEDAL BUMPERS

B-35184	Rubber, mounts to floor	32-34	3.00 pr
48-700386	Rubber mounts to floor	35-36	3.50 pr
91A-2476/7527	Bumper & floor seal, sponge, 1 pair, fits on pedal arms	39-48	6.00 pr

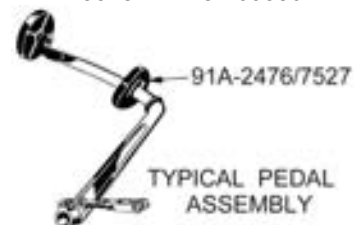

FOR BRAKE PEDAL BUSHINGS, SEE TRANSMISSION SECTION

SPINDLE BOLT (KING PIN) SETS & PARTS

B-3111	Passenger & pick-up, includes all hardware	32-34	120.00 set
48-3111	Passenger & commercial.....	35-36	100.00 set



78-3111	Passenger & commercial.....	37-41	40.00 set
21A-3111	Passenger & commercial.....	42-48	60.00 set



X-3111-B	Spindle bolt repair kit, same as above sets but does not include king pins, not for full size truck.....	32-41	25.00 kit
----------	--	-------	-----------

B-3123	Thrust bearing for spindle bolt	32-48	6.75 ea
78-3107	Spindle bolt adjusting shims	32-48	.50 ea
11A-3110	Spindle bolt bushing, 1.06 long....	32-41	1.75 ea
21A-3110	Spindle bolt bushing, 1.37 long....	42-52	ASK
B-3122	Spindle bolt locking pin assembly	28-48	10.00 ea

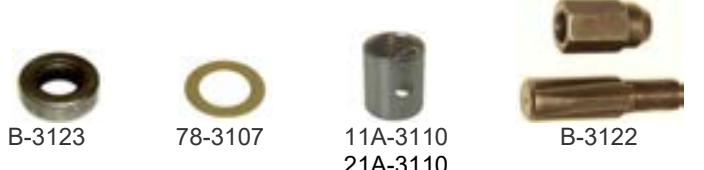

TIE ROD TUBES (LESS ENDS)

B-3281	Passenger & commercial, 43.5"....	32-34	ASK
48-3283	Passenger & commercial, 45".....	35-36	60.00 ea
78-3283	Passenger & commercial, 43.6"....	37-41	60.00 ea
21A-3283	Passenger & commercial, 45.8"....	42-48	60.00 ea



TIE ROD ENDS

B-3285	Tie rod end housing, right hand, no internal parts*	32-34	13.50 ea
B-3286	Tie rod end housing, left hand, no internal parts*	32-34	13.50 ea

*See B-3305-RK drag link repair kit (next page) for internal parts

11A-3270	Tie rod end assembly, right hand, cars & pickups	35-48	17.00 ea
11A-3271	Tie rod end assembly, left hand, cars & pickups (also used in drag link).....	35-48	17.00 ea

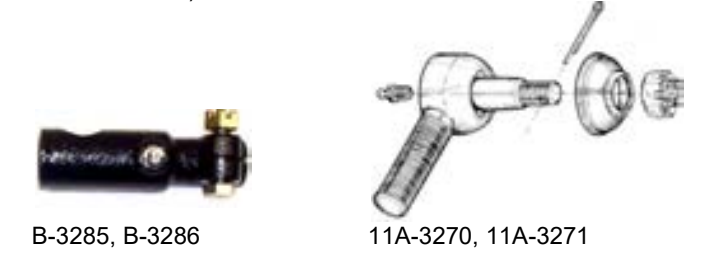

DRAG LINKS

B-3305	Drag link tube only, passenger and commercial, see B-3305-RK drag link repair kit for internal parts.....	1932	57.00 ea
11Y-3306	Drag link assembly, includes both ends, 1935-40 cars & 1935-41 pickups.....	35-41	85.00 ea
11A-3306	Drag link assembly, includes both ends, bent end type, car, NOS.....	1941	75.00 ea
21A-3306	Drag link assembly, includes both ends, cars & pickups.....	42-48	100.00 ea



TIE ROD & DRAG LINK MISC. PARTS

B-3305-RK	Tie rod, drag link repair kit, internal parts, 10 pieces.....	32-34	12.00 kit
48-3287	Tie rod end clamp (Bolt & nut not included)	35-48	4.00 ea
11A-3310	Tie rod end coupling sleeve, all passenger & commercial.....	35-48	9.50 ea



B-3311	Drag link ball stud, 1" diameter	32-34	9.00 ea
BB-3332	Drag link and tie rod rubber seal*, set of 4	32-34	8.00 set
BB-3333	Metal caps for B-3332 above, set of 4	32-34	7.00 set
8M-3332	Drag link and tie rod rubber seal, set of 4	35-48	5.00 set
48-3332	Drag link and tie rod rubber seal, set of 4 (Similar to 8M-3332 except for design)	35-48	6.00 set



RADIUS ROD RUBBER BUSHINGS

B-3446	Rubber bushing 1932-1940 passenger and 1932-1941 commercial.....	32-40	2.50 ea
11A-3446	Rubber bushing, all passenger	41-48	3.00 ea



SWAY BAR PARTS

01A-3533/4	Front stabilizer swivels, cars & pickup	40-41	70.00 pr
11A-3558	Stabilizer bar bushings, pair	40-41	8.00 pr
21A-5484	Stabilizer bar bushings, pair	42-48	8.00 pr
51A-5464	Stud for spring perch.....	40-41	5.00 ea

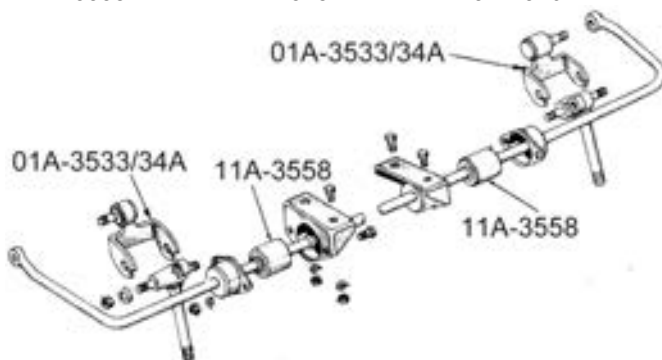

1940-41 Deluxe Sway Bar

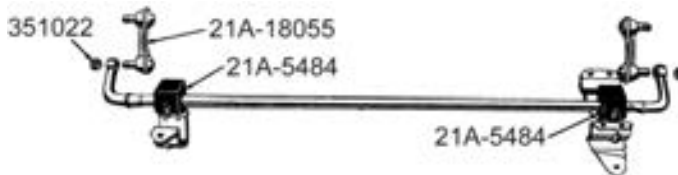

1942-48 Passenger Stabilizer

PERCH NUT

B-3036	Special design like original	32-48	3.50 ea
--------	------------------------------------	-------	---------



TRACK BAR & SHOCK BUSHINGS

51A-18197	Rubber.....	42-48	3.00 ea
-----------	-------------	-------	---------



SHOCK LINKS & PARTS

B-18055-CS	Dog bone type, holes on opposite side, includes B-18060 rubber bushings.....	28-34	11.00 ea
B-18055-B	Dog bone type, holes on same side, includes B-18060 rubber bushings.....	32-35	14.00 ea
B-18060	Shock absorber link bushing set, 8 rubber balls	32-35	5.00 ea
48-18055	Passenger & pickup, 3"*	35-40	15.00 ea
78-18055	Passenger & pickup, 4"*	37-48	15.00 ea
99A-18055	Passenger, 4.75"*	41-48	15.00 ea
21A-18055	Passenger, 2.39", stabilizer*	46-48	15.00 ea
01Y-18055	Pickup only, NOS	42-47	30.00 ea
351022	Self locking Marsden nut for Above, 3/8-24 thread	35-48	.75 ea



B-18055-CS



B-18055-B



B-18060



48, 78, 99A & 21A-18055



01Y-18055



351022

*All measurements center to center of studs.

LEVER ACTION SHOCK HARDWARE

Sets include all necessary bolts, nuts & washers for 4 shocks

A-18047/52-MB	Arm to shock mounting set of 4 bolts with castle nuts	28-33	7.50 set
40-18047/52-MB	Arm to shock mounting set of 2 bolts with castle nuts.....	34-36	3.75 set
A-18015-MB	Shock to frame mounting set....	33-36	7.00 set

TUBE SHOCK CONVERSION KITS

Includes shocks, mounting brackets, hardware and instructions for installation. Bolt on components, some drilling required. CANNOT BE INSTALLED ON CARS WITH MECHANICAL BRAKES

48-18124-KIT	Front shock kit, cars & pickup... 35-36	200.00 kit
48-18125-KIT	Rear shock kit, cars & pickup ... 35-36	200.00 kit
78-18124-KIT	Front shock kit, 37-40 car & 37-41 pickup.....	37-41 200.00 kit
78-18125-KIT	Rear shock kit, 37-40 cars & 37-41 pickups	37-41 200.00 kit
11A-18124-KIT	Front shock kit, cars only.....	42-48 200.00 kit
11A-18125-KIT	Rear shock kit, cars only	42-48 200.00 kit



78-18124-KIT



78-18125-KIT

LEAF SPRING CLAMPS

Includes bolt & nut

A-5330-B	1 3/4" wide, plain steel	4.00 ea
B-5724-A	2 1/4" wide, plain steel	5.00 ea
HR-330	1 3/4" wide, stainless steel, by Drake.....	30.00 pr
HR-331	2" wide, stainless steel, by Drake.....	30.00 pr
HR-332	2 1/4" wide, stainless steel, by Drake.....	30.00 pr



SPRING CENTER BOLT & PAD

A-5345-F	Front spring center bolt.....	32-48	1.75 ea
A-5345-R	Rear spring center bolt	32-48	2.00 ea
48-5599	Pad between spring & chassis front or rear, 1-1/2" x 8"	32-39	2.00 ea
11A-5599	Pad between spring & chassis front or rear, 2" x 8".....	32-48	2.00 ea



A-5345-F, A5345-R



48-5599, 11A-5599

SPRING LINERS, FRONT OR REAR

A-5310-P1	1 3/4" x 20' roll, front.....	32-34	10.00 roll
A-5310-P2	2" x 20' roll, front.....	35-48	12.00 roll
A-5310-P3	2 1/4" x 20' roll, rear.....	32-48	14.00 roll

Note: Polyslide liners designed to control friction between spring leaves. Molded black with lid on sides. Cut to lengths as needed. Liners add to spring thickness so be sure U bolts are of sufficient length.



Spring liner

FRONT SPRING U-BOLTS

1932-1948 Cars & 1932-1941 pickups.

B-5455-S	L = 5", round top with nuts & cotter pins	28-34	16.00 set
A-5455-S	Same as above except square top L=4"	28-34	16.00 set
48-5455	Cars & pickups L = 5.24" *	36-41	ASK
68-5455	Cars & pickups L = 4.49" *	36-39	12.00 ea
51A-5455	Cars only L = 5.64" *	42-48	ASK
A-5458	Front spring U-bolt clip bar	28-34	8.75 ea
11A-5458	Front spring clip bar, 1935-1948 cars & 1935-1941 pickups	35-48	ASK
A-5455-N	Castle nuts for U Bolts, set of 4 ...	28-34	3.75 set
A-5706	Castle nuts for U Bolts, set of 4 ...	35-48	5.50 set

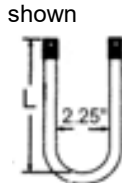

B-5455-S
A-5455-S



51A-5455



A-5458



A-5455, A-5706



11A-5458

REAR SPRING U-BOLTS

1932-1948 Cars & 1932-1941 pickups.

B-5705-S	Includes nuts, L = 5.25" cut down as needed, set of 2.....	28-40	15.00 set
51A-5705-C	Cars L = 7.75".....	41-48	ASK
B-5710-C	Rear spring clip bar	32-41	7.50 ea
11A-5709-B	Cars, rear spring bar.....	41-48	ASK
A-5706	Castle nuts for U Bolts, set of 4 ...	32-48	5.50 set



B-5705-S



51A-5705-C

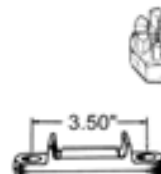

B-5710-C



A-5706

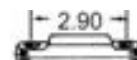

11A-5709-C

FRONT SPRING ASSEMBLIES (Replacement)

40-5310	Cars & pickups.....	33-34	ASK
21C-5310-B	Pickups, 2 required	42-47	ASK

FRONT SPRING SHACKLE KITS

1932-1948 Cars & 1932-1941 Pickups.

One kit does both sides of spring.

B-5304-S	With steel bushings, cars & Pickups	32-34	25.00 kit
48-5304-S	With steel bushings, 1935-1940 cars & 1935-1941 pickups.....	35-41	20.00 kit
11A-5304-S	Cars only, steel bushings	1941	20.00 kit
21A-5304-S	Cars only, with bushings, (1) rubber, (1) steel	42-48	30.00 kit



B-5304-S



48-5304-S

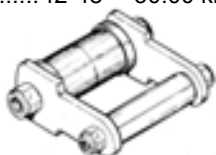

11A-5304-S

FRONT SPRING SHACKLE PARTS

1932-1948 Cars & 1932-1941 pickups.

40-5463	Shackle pin, 3/4 " OD, 3.37" long part of B-5304-S kit above	32-34	13.00 ea
40-5464	Shackle pin, 7/8" OD, 3.37" long part of B-5304-S, kit above	32-34	13.00 ea
51A-5464	Shackle pin, 3/4" OD, 3.55" long, part of 48-5304-S, 11A-5304-S & 21A-5304-S kits above.....	35-48	5.00 ea
21A-5465	Shackle pin, part of lower, use with rubber bushings (21A-5467) listed below	42-48	ASK
21A-5467	Shackle rubber bushing	42-48	2.00 ea



Typical shackle pin



21A-5467, 21A-5719

FRONT SPRING SHACKLE PARTS

1942-1947 Pickups

21C-5468	Shackle bar, 2 required *	42-47	4.75 ea
21C-5469	Shackle bar, 2 required *	42-47	4.75 ea
21C-5465	Shackle bolt, 6 required *	42-56	6.00 ea
21C-5344	Front spring bushing, 2 required* ..	42-56	7.00 ea
21C-5348	Main leaf bushing, 4 required *	42-56	6.00 ea
B3C-5455	U-bolt with nuts, 4 required	42-48	8.00 ea

*Quantities stated are per vehicle

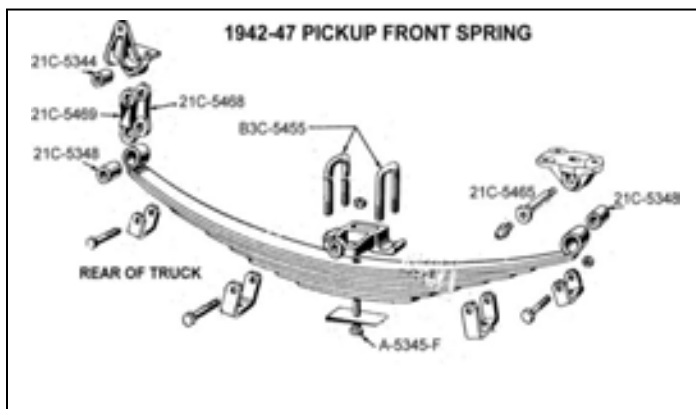

REAR SPRING ASSEMBLIES (Replacement)

21C-5560	Pickups, 2 required.....	42-47	ASK
----------	--------------------------	-------	-----

REAR SPRING SHACKLE KIT

1932-1948 Cars & 1932-1941 Pickups.

One kit does both sides of spring.

B-5630-S	With steel bushings, cars & pickup, NORs.....	32-34	40.00 kit
48-5630-S	With steel bushings, 1935-1940 cars & 1935-1941 pickups	35-48	24.00 kit
11A-5630-S	With steel bushings, cars only	1941	20.00 kit
21A-5630-S	With bushings, (1) steel, (1) rubber cars only	42-48	30.00 kit

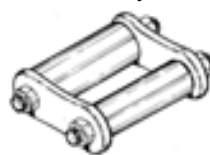

B-5630-S

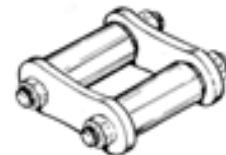

48-5630-S

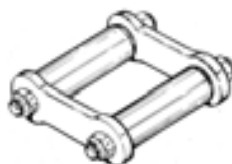

11A-5630-S

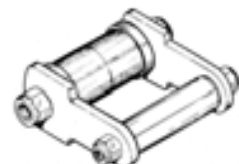

21A-5630-S

REAR SPRING SHACKLE PARTS

1932-1948 Cars & 1932-1941 pickups.

51A-5713	Shackle pin, 3/4" OD, 3.8" long ...	32-41	6.00 ea
40-5714	Shackle pin, 7/8" OD, 3.8" long, ...	32-34	13.00 ea
21A-5714	Shackle pin, use with rubber bushings 21A-5719 below	42-48	ASK
21A-5719	Shackle rubber bushing	42-48	2.75 ea

REAR SPRING SHACKLE PARTS

1942-1947 Pickups

21C-5780	Shackle pin, 6 required *	42-56	6.00 ea
82Y-5782	Shackle pin locking pin, 6 required*	42-56	1.25 ea
21C-5781	Spring leaf front & rear bushing, 4 required *	42-56	7.50 ea
21C-5776	Shackle with bushing, 2 required *	42-52	40.00 ea
21C-5791	Shackle bushing only, 2 required *	42-52	6.00 ea
21C-5775	Front & rear hangar, 4 required ...	42-47	N/A
21C-5701-C	U-bolt with nuts, 4 required	42-48	10.00 ea

*Quantities stated are per vehicle

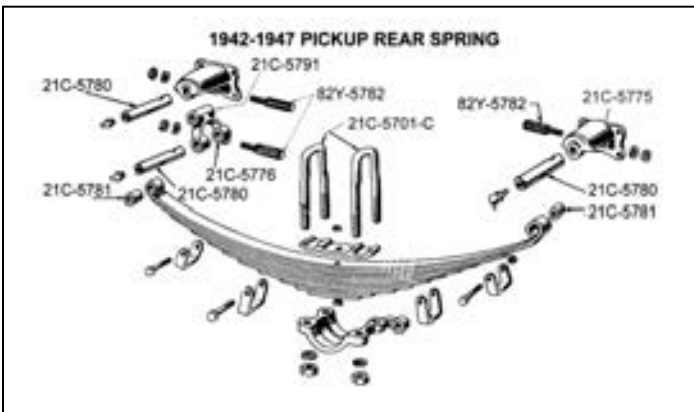

FRONT AXLE RUBBER BUMPERS

B-3020	Cars & pickups (sold each)32-34	6.00 ea
48-3020	Cars & pickups (sold each)35-38	10.00 ea
91A-3020-D	39-40 cars & 39-41 pickups (sold in pairs)39-41	32.00 pr
11A-3020	Cars, also used on rear axle (each)41-42	7.50 ea
21C-3020	Pickups (sold each)42-47	8.50 ea
51A-3020	Cars (sold each)45-48	7.50 ea

Note: Above years stated may not be accurate for your car, check illustrations below for correct bumpers.

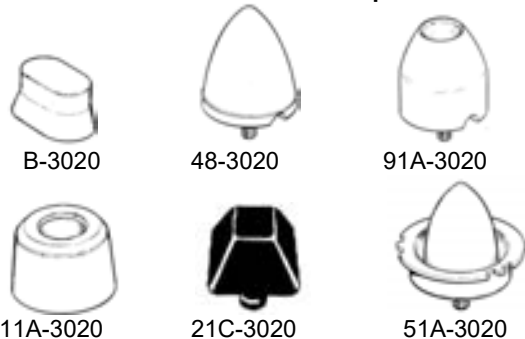

REAR AXLE RUBBER BUMPER

B-5783	Cars & pickups (sold each) 1932	8.00 ea
40-5783	Cars & pickups (sold each)33-34	10.50 ea
48-5783-D	Cars & pickups (sold in pairs)35-38	25.00 pr
91A-5783-D	39-40 cars & 39-41 pickups39-40	24.00 pr
11A-3020	41-48 cars & 42- 1954 pickups41-54	7.50 ea

Note: Above years stated may not be accurate for your car, check illustrations below for correct bumpers.

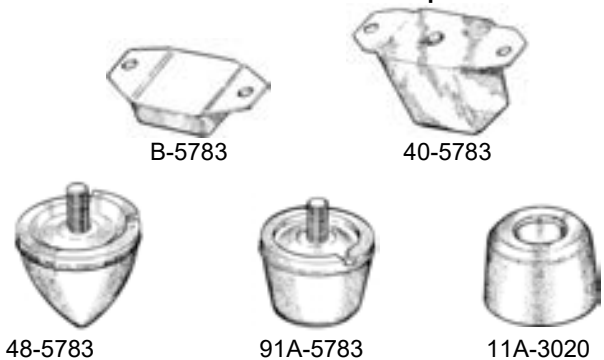

SPREADER BARS BETWEEN FRAME HORNS

Available by either Bob Drake or Vintique

B-5041-SS	Front, polished stainless steel w / mounting hardware, by Drake 1932	95.00 ea
	By Vintique1932	60.00 ea
B-18575-SB	Rear, polished stainless steel w / mounting hardware, by Drake 1932	130.00 ea
	By Vintique1932	90.00 ea
40-5081-B	Rear plain steel with cast ends33-34	125.00 ea

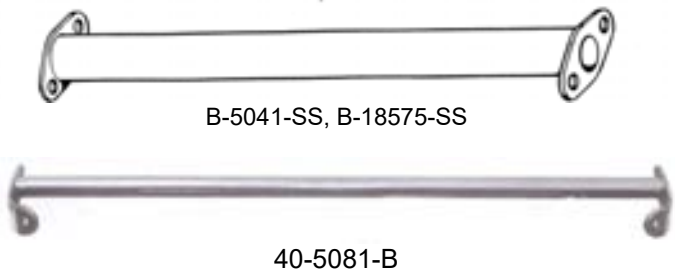

REAR FRAME HORN COVER & APRON CHANNEL

B-16399	Rear frame horn cover, gas tank apron, die stamped, includes rubber channel & plugs 1932	160.00 pr
B-16398	Rubber channel & plug kit only, 6 pieces 1932	6.50 kit

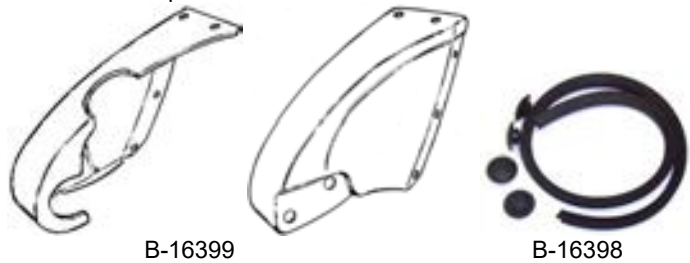

BODY TO FRAME WEBBING & ANTI-SQUEAK

Original Style

B-5010-A	1" x 1/16" x 25' roll 18.00 roll
B-5000-A1	1 1/2" x 1/16" x 20' roll 17.00 roll
B-5010-C	2" x 1/16" x 25' roll 22.50 roll
B-5000-B1	1 1/2" x 1/8" x 20' roll 20.00 roll
B-5000-AS	1 1/2" x 1/8" x 20' roll, w/self adhesive 24.00 roll
B-5000-B2	2" x 1/8" x 20' roll 21.00 roll
B-5000-BS	2" x 1/8" x 20' roll, w/self adhesive 28.00 roll
B-5010-E	2" x 1/4" x 10' roll, used for shimming 26.00 roll



BODY TO FRAME WEBBING & CUSHION PADS

Non Original Style

SHOK-LINER by Bob Drake, made using natural rubber.

BD-5010-A	1/8" thick x 2" wide x 25' long roll 50.00 ea
-----------	--------------------------------------	----------------



Back of material self adhesive

Face of material grooved to interlock with shims below

SHOK-SHIMS by Bob Drake, made using natural rubber.

BD-5001-K	Pack of 50 pieces, 2" outer diameter 3/8" hole. 10 pieces each of 1/8", 3/16" 1/4", 5/16" & 3/8" thick 50.00 ea
-----------	--	----------------



BODY TO FRAME MOUNTING PARTS

B-5000-SH	Body to frame shim	32-48	.50 ea
78-5000-MB	Body to frame bolt kit	37-40	19.50 kit
11A-5000-MB	Body to frame bolt kit	41-48	12.00 kit



B-5000-SH



78-5000-MB, 11A-5000-MB

48-5001	Pad set, 19 pieces	35-36	80.00 set
---------	--------------------------	-------	-----------



48-5001

78-5001	Pad set, 34 pieces	37-40	45.00 set
---------	--------------------------	-------	-----------



78-5001

01A-5001	Pad set, convertible, 33 pieces	1940	60.00 set
----------	--------------------------------------	------	-----------



01A-5001

BODY TO FRAME MOUNTING PARTS continued

11A-5001	Pad set, 19 pieces	1941	35.00 set
----------	--------------------------	------	-----------



11A-5001

11A-5001-B	Pad set, 15 pieces, convertible....	1941	35.00 set
------------	-------------------------------------	------	-----------



11A-5001-B

21A-5001	Pad set, 25 pieces	42-48	35.00 set
----------	--------------------------	-------	-----------



21A-5001

7C-5400-SS	Pad set, pick-up only, 14 pieces..	48-52	25.00 set
------------	------------------------------------	-------	-----------



7C-5400-SS

STEERING WORM GEAR

B-3524	13:1 ratio without shaft.....	32-34	58.00 ea
40-3524	15:1 ratio without shaft.....	32-34	58.00 ea
48-3524	15:1 ratio without shaft.....	35-36	58.00 ea
68-3524	17:1 ratio without shaft.....	35-36	64.00 ea
78-3524	18:1 ratio without shaft		
	37-48 cars & 37-52 pickups	37-48	65.00 ea
01A-3524	With shaft, cars, shaft must be drilled to adapt to steering lock	37-40	195.00 ea
11A-3524	With shaft, cars	42-48	195.00 ea

STEERING SECTOR SHAFT

B-3575-A	13:1 ratio.....	32-34	90.00 ea
B-3575-B	15:1 ratio.....	32-34	108.00 ea
48-3575	15:1 ratio.....	1935	90.00 ea
68-3575	17:1 ratio.....	1936	78.00 ea
7RC-3575-X	Sector replacement roller & pin kit. 37-48 pass & 37-52 F1pickup (To replace your used roller but use your present sector shaft)..	37-52	70.00 kit

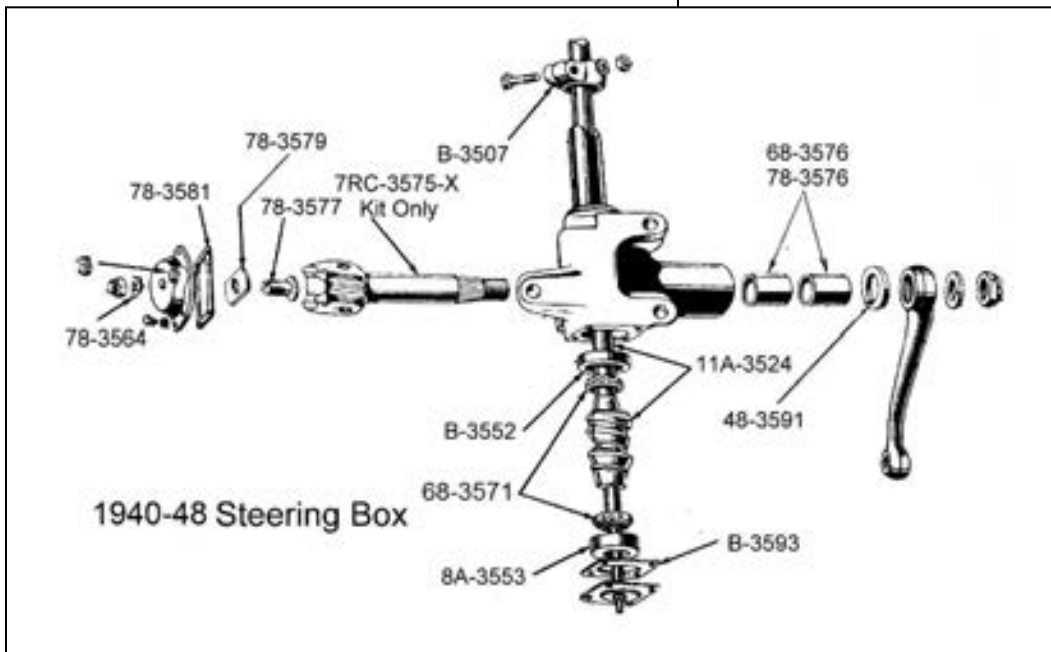
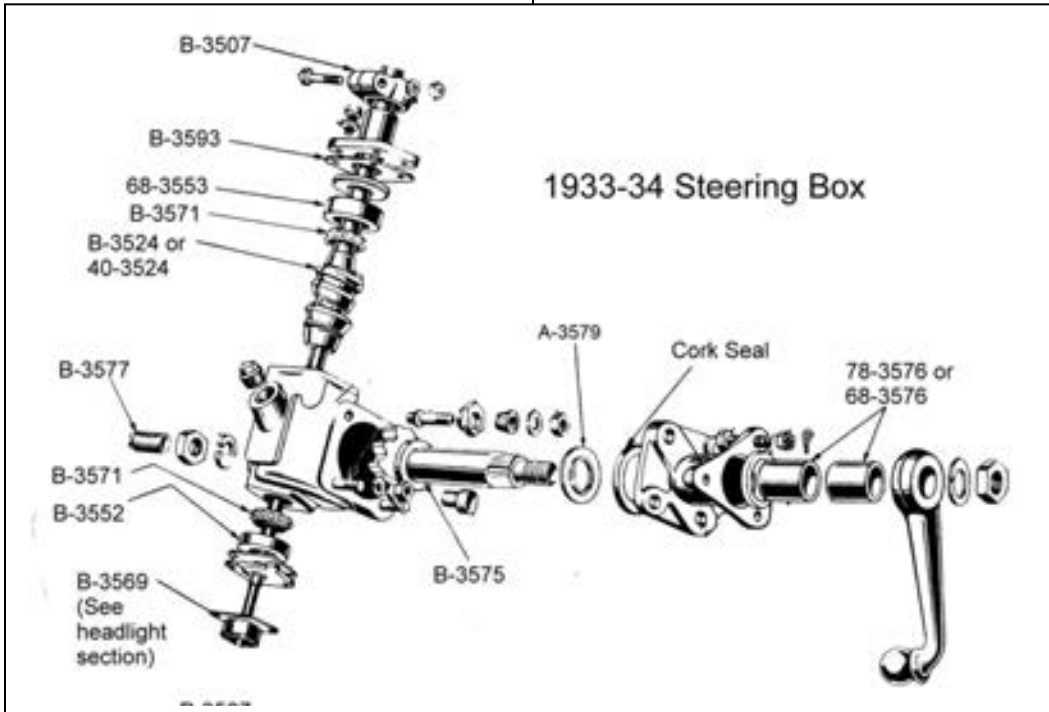

Use for proper lubrication we recommend 600W oil, 1 quart bottle. See page 151 for pricing

STEERING BOX PARTS

78-3564	Thrust screw star lock washer.....	37-48	5.00	ea
B-3569	Steering gear light switch bracket	32-37	3.25	ea
B-3577	Sector thrust screw with check nut.....	32-36	5.25	ea
78-3577	Sector thrust screw	37-48	3.00	ea
A-3579	Sector adjuster washer	32-36	2.00	ea
78-3579	Sector adjuster washer	37-48	5.00	ea
B-3581-S	Steering box gasket set, top quality, 10 pieces	32-36	12.00	set
78-3581-S	Steering box gasket set, 1937-48 pass. & 1937-47 pickup, 7 pieces	37-48	6.00	set
78-3581	Steering box housing gasket, 1937-48 pass & 1937-47 pickup	37-48	1.50	ea
7RC-3581	Steering box housing gasket, pickup only.....	48-60	1.75	ea
7RC-3581-S	Steering box gasket set, pickup....	48-60	12.00	set
48-3591	Steering box oil seal, 1935-1948 passenger & 1935-1947 pickup	35-48	2.75	ea
8A-3591	Steering box oil seal, 1948-1952 pickup & 1949- early 1956 pass.....	48-56	2.50	ea
B-3593-A	Steering shim gasket, .003 thk * ..	32-56	1.00	ea
B-3593-B	Steering shim gasket, .005 thk * ..	32-56	1.00	ea
B-3593-C	Steering shim gasket, .010 thk * ..	32-56	1.00	ea

*These gaskets included in B-3581-S & 78-3581-S

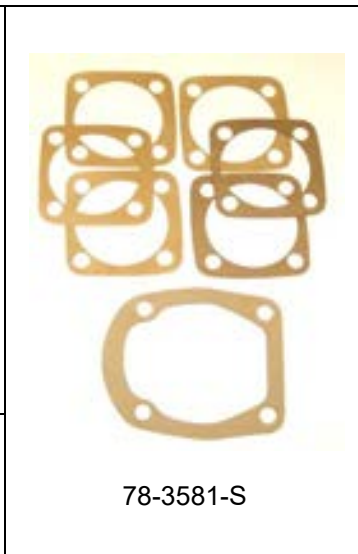
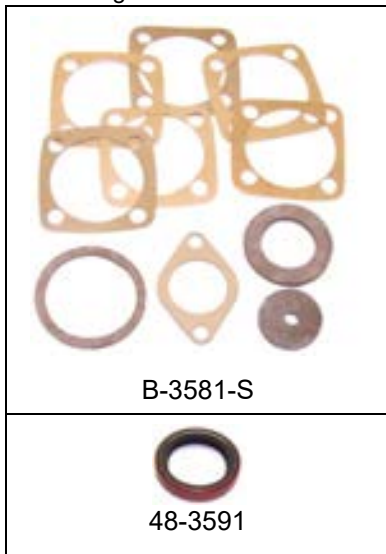

STEERING COLUMN UPPER BUSHING

51A-3517-A	Rubber bushing, modified with insert for easier turning	32-48	6.00	ea
21A-3517	Bearing *	42-70	12.00	ea

* Note: Some 42-48 cars used this bearing, not interchangeable with 51A-3517-A, check your column before ordering

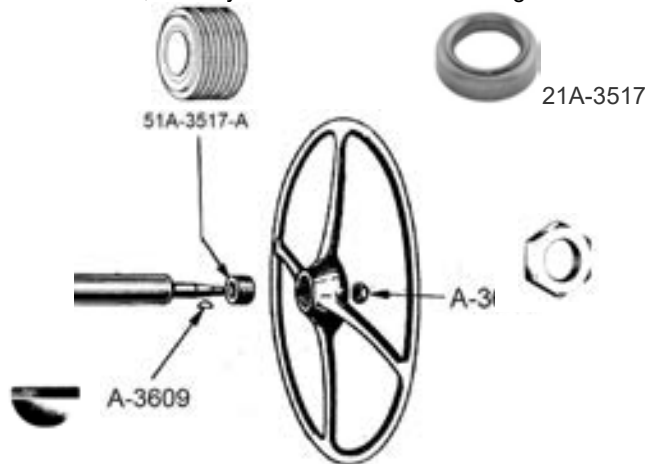

STEERING WHEEL KEY & NUT

A-3609	Key	32-48	1.25	ea
A-3610	Nut.....	32-67	.75	ea

HORN BUTTON PARTS

01A-3626	Horn button spring, 1940 cars & 1940-47 pickups	40-41	2.75	ea
21A-3626	Horn button spring, cars only.....	42-48	6.00	ea
11A-3672	Horn button insulator , cars only ..	41-48	3.00	ea
6A-3628	Horn button retainer, stainless holds plastic button horn button onto ring, cars only	41-48	12.00	ea
HR-3627	Horn switch button for universal Applications		8.00	ea



STEERING WORM BEARINGS AND RACES

B-3552	Lower bearing race (cup)	32-36	11.00	ea
68-3553	Upper bearing race .875 " thick....	32-36	65.00	ea
B-3552	Upper bearing race (cup)	37-57	7.50	ea
8A-3553	Lower bearing race (cup)	37-57	26.00	ea
B-3571	Bearing, 2 required	32-35	16.00	ea
68-3571	Bearing, 2 required	36-57	9.00	ea



HORN BUTTON WIRING

A-3616-RK	Horn rod wire repair kit	32-39	7.50	kit
01A-3671-D	Horn button wire, 40 cars, 40-47 pickups	40-47	28.00	ea
11A-14308	Horn button wire 62", Super Deluxe, cars.....	41-48	6.50	ea
21A-14308	Horn button wire 62", Deluxe & Special. Cars, less rivet & plug....	41-48	6.00	ea



SECTOR SHAFT BUSHING AND NEEDLE BEARING

2 of each required

78-3576	Bushing, car & pickup	32-48	3.00	ea
68-3576	Needle bearing, car & pickup	36-56	12.00	ea

HORN BUTTON-FORD

01A-3627-A	Brown, standard car.....	1940	18.50	ea
01A-3627-B	Red-Brown, "FORD DE LUXE"	1940	18.50	ea
01C-3627	Black, pickup.....	40-41	37.00	ea
01A-3627-P	Gloss Black, plain, no emblem.....	1940	18.50	ea
11C-3627	Black, pickup (Also fits 1940-41)..	42-47	18.50	ea



01A-3627
01C-3627



01A-3627-B



01A-3627-P



11C-3627

51A-3627-B	Blue background, red "FORD" Super Deluxe, car	1946	50.00	ea
51A-3627-C	Tan background, red "FORD" Convertible, wagon, car	1946	50.00	ea
6A-3627	Gold background, silver "FORD" ..	42-48	35.00	ea
6A-3627-B	Silver/gold background, red "FORD", car	42-48	35.00	ea



51A-3627-B



51A-3627-C



6A-3627



6A-3627-B

HORN BUTTON-MERCURY

59A-3627-A	Red background, 46-early 47	46-47	60.00	ea
59A-3627-B	White background, late 47 to 48 ...	47-48	60.00	ea



59A-3627-A



59A-3627-B

STEERING WHEELS

68-3600-A	Passenger & pickup, molded black	35-36	N/A
78-3600-A	Standard passenger & pickup, molded black	37-39	N/A



68-3600-A



78-3600-A

91A-3600-B	"Banjo" style w/stainless steel spokes, will also fit 1937-1938.....	1939	N/A
A-1130-DSS	Center cap for above wheels, (actually a 1930-31 Model A hub cap). Not functional as horn button, polished stainless steel.....	13.00	ea



91A-3600-B



A-1130-DSS

01A-3600-D	Deluxe, molded gloss black, 1940 cars, also fits 40-47 pickups 01A-3627-P horn button & 01A-3626 button spring included ..	1940	240.00	ea
01A-3600-D15	Deluxe wheel as above except smaller 15" diameter for custom applications. Accepts taper shaft ..	1940	240.00	ea
6A-3600-B	"Big Hub" type, molded black, cars only	41-48	175.00	ea
7C-3600	Pickup truck only	48-52	200.00	ea



01A-3600-D



6A-3600-B

STEERING BOX MOUNT

Heavy gauge die stamped steel. Mounts 1937-40 steering box into original frame or into 1935-36 frame. Bolt on.				
78-5104	Steering box mount.....	37-40	40.00	ea





Light Switch & Horn Rod Assembly

Ignition Lock to Dash Pad 40-3682

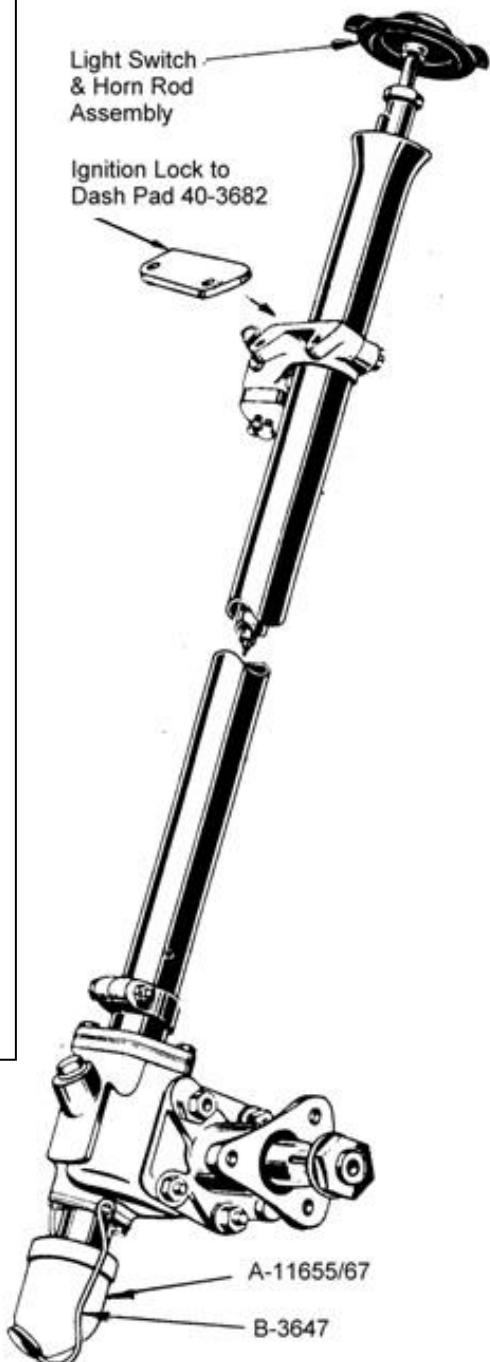

1933-34 Steering Column Assembly



1937-39 Steering Box / Light Switch Assembly

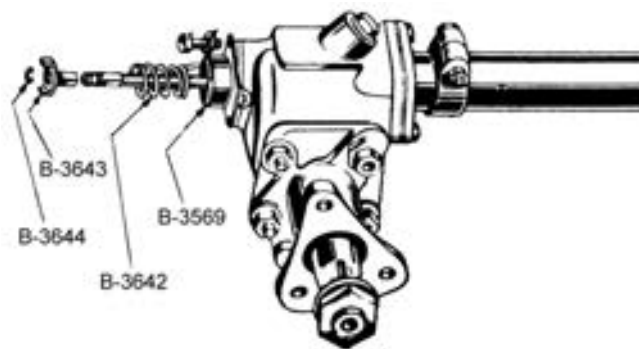

Typical Steering Box Assembly Detail (1933-34 Shown)

HEADLIGHT SWITCH & HORN ROD PARTS

A-11655/67	Light switch body housing	32-39	16.00 ea
B-3616	Light switch & horn rod assembly....	1932	65.00 ea
B-3642	Spider spring	32-39	1.00 ea
B-3643	Spider.....	32-39	6.00 ea
B-3644	Spider retainer, U-shaped	32-38	.50 ea



A-11655/67



B-3642



B-3643



B-3644

B-3647	Bail, holds switch to bottom of steering column.....	32-36	2.00 ea
78-3647	Bail, cadmium.....	37-39	4.00 ea
B-3569	Light switch bracket (This is the flange that the light switch B-11655-S fits into)	29-37	4.00 ea



B-3647



78-3647



B-3569

IGNITION LOCK ASSEMBLY TO DASH RUBBER PADS

B-3682	Passenger	1932	2.00 ea
40-3682	Passenger	33-34	2.00 ea
48-3682	Passenger & 1932-1947 pickup...	35-37	2.00 ea



B-3682



40-3682



48-3682

81A-3682	Passenger	38-39	5.00 ea
01A-3682	Passenger	1940	2.00 pr
11A-3682	Passenger	41-48	4.00 ea



81A-3682



01A-3682



11A-3682

REAR AXLE SHAFT, DRIVE SHAFT & PARTS

B-4030	Differential drain plug	32-48	1.00 ea
B-4030-M	Differential plug with magnet.....	32-48	4.00 ea
A-4235	Rear axle shaft, 24 tooth, 32.09" ..	28-32	ASK
48-4235	Rear axle shaft, 18 tooth, 32.85" ..	35-41	ASK
B-4245	Rear axle inner grease seal, also for drive shaft.....	32-48	2.25 ea
A-4246	Seal driver for B-4245 (above).....	32-48	9.50 ea
48-4605	Drive shaft, hollow for use with axles having 10 spline pinion	35-38	ASK
48-4607	Drive shaft pin 2.04" long *.....	32-38	1.50 ea
68-4607	Drive shaft pin 1.70" long **	37-48	1.50 ea
68-4684-B	Drive shaft coupling sleeve, 6 spline, 37-48 car & 37-41 pickup ...	37-48	44.00 ea
48-4684	6 x 10 spline adapter, 1935-1948 cars & 1935-1941 pickup	35-48	80.00 ea

*Use with 10 spline pinion

**Use with 6 spline pinion

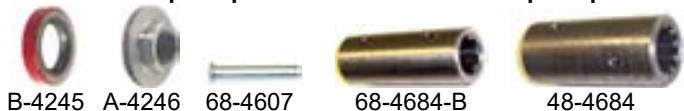

AXLE HOUSING END REPAIR SLEEVE

B-4012	Replaces worn wheel bearing surface, requires machining	32-48	32.00 ea
--------	--	-------	----------

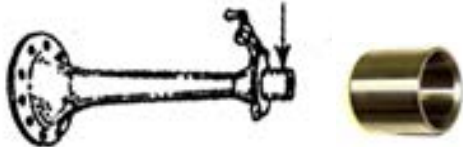

REAR AXLE HOUSING GASKETS

B-4035	.006", .010" or .016 thick, (please specify size required, 4 cylinder ..	32-34	3.50 ea
18-4035-A	.003" thick, V8	32-48	2.75 ea
18-4035-B	.005" thick, V8	32-48	2.75 ea
18-4035-C	.009" thick, V8	32-48	2.75 ea
18-4035-S	Complete set including (2) each axle housing gaskets .003", .005" .007" & .009" thick plus U joint gaskets (2) B-4515, (1) B-4516, (1) 48-4507 & (2) B-1183	35-48	27.50 set



DIFFERENTIAL HOUSING BEARINGS & RACES

B-4221	4 cylinder bearing.....	28-32	39.00 ea
B-4222	Bearing race (cup)	28-32	26.00 ea
18-4221/2	8 cylinder bearing & race (cup) (2 sets required per vehicle).....	32-36	50.00 set
18-4222	Race (cup)	32-36	20.00 ea
68-4221	Bearing	36-48	32.00 ea
68-4222	Race (cup)	36-48	20.00 ea

TORQUE TUBE & UNIVERSAL JOINT GASKETS

18-4507	Torque tube rear gasket	32-34	4.00 ea
48-4507	Torque tube rear gasket	35-48	2.00 ea
B-4515	Universal joint housing gasket	32-48	1.50 ea
B-4516	Universal joint housing cork gasket.....	32-48	2.00 ea

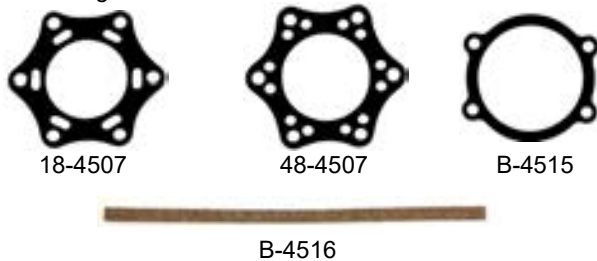

RING & PINION GEAR SETS

40-4209-E	3:54:1Ratio, cars & pickup (High speed ratio).....	33-34	495.00 set
68-4209-E	3:54:1Ratio, 1935-1948 cars & 1935-1941 pickup* (High speed ratio).....	35-48	395.00 set
68-4209-A	3:78:1Ratio, 1933-1948 cars & 1933-1941 pickup *	35-48	425.00 set
18-4200-KIT	Rear axle installation kit including bearings, races, seal & gaskets...	32-34	ASK
48-4200-KIT	Rear axle installation kit including bearings, races, seal & gaskets...	35-36	ASK
68-4200-KIT	Rear axle installation kit including bearings, races, seal & gaskets...	37-48	ASK

*Note: Above pinions are 6 spline, 39 x 11 tooth count. Pre 1938 vehicles with 10 spline/hollow drive shafts will require modification.

DRIVE PINION BEARINGS & RACES

B-4616	Double race (cup), 4 cylinder.....	28-32	53.00 ea
18-4621	Bearing, cars & pickups, 8 cyl.....	32-34	20.00 ea
18-4616-SET	Bearing/race set with (1) 18-4616 race & (2) 18-4621 bearings.....	32-34	100.00 set
48-4621	Bearing, cars & pickups.....	35-48	35.00 ea
48-4616	Double race, cars & pickups.....	35-48	55.00 ea
18-4625-A	Pinion pilot bearing	32-48	20.00 ea
18-4629	Pinion bearing retainer, cars pickups, less rivets	32-48	5.00 ea

PINION LOCKNUT, WASHER & GREASE SEAL

18-4634	Pinion locknut	32-50	5.00 ea
01Y-4636	Pinion nut lock washer.....	32-50	4.50 ea
01Y-4637	Pinion bearing thrust washer	32-50	2.00 ea
01Y-4676	Pinion grease seal, pickup only ...	42-47	6.00 ea

DRIVE SHAFT ROLLER BEARING & SLEEVE

B-4645	Drive shaft roller bearing, car & pickup.....	32-48	13.00 ea
B-4655	Drive shaft roller bearing sleeve, car & pickup.....	32-48	8.00 ea



ORDER & INFORMATION LINE 1- 508-278-3980 TOLL FREE 1-800-508-3980 Email: joesantique@charter.net

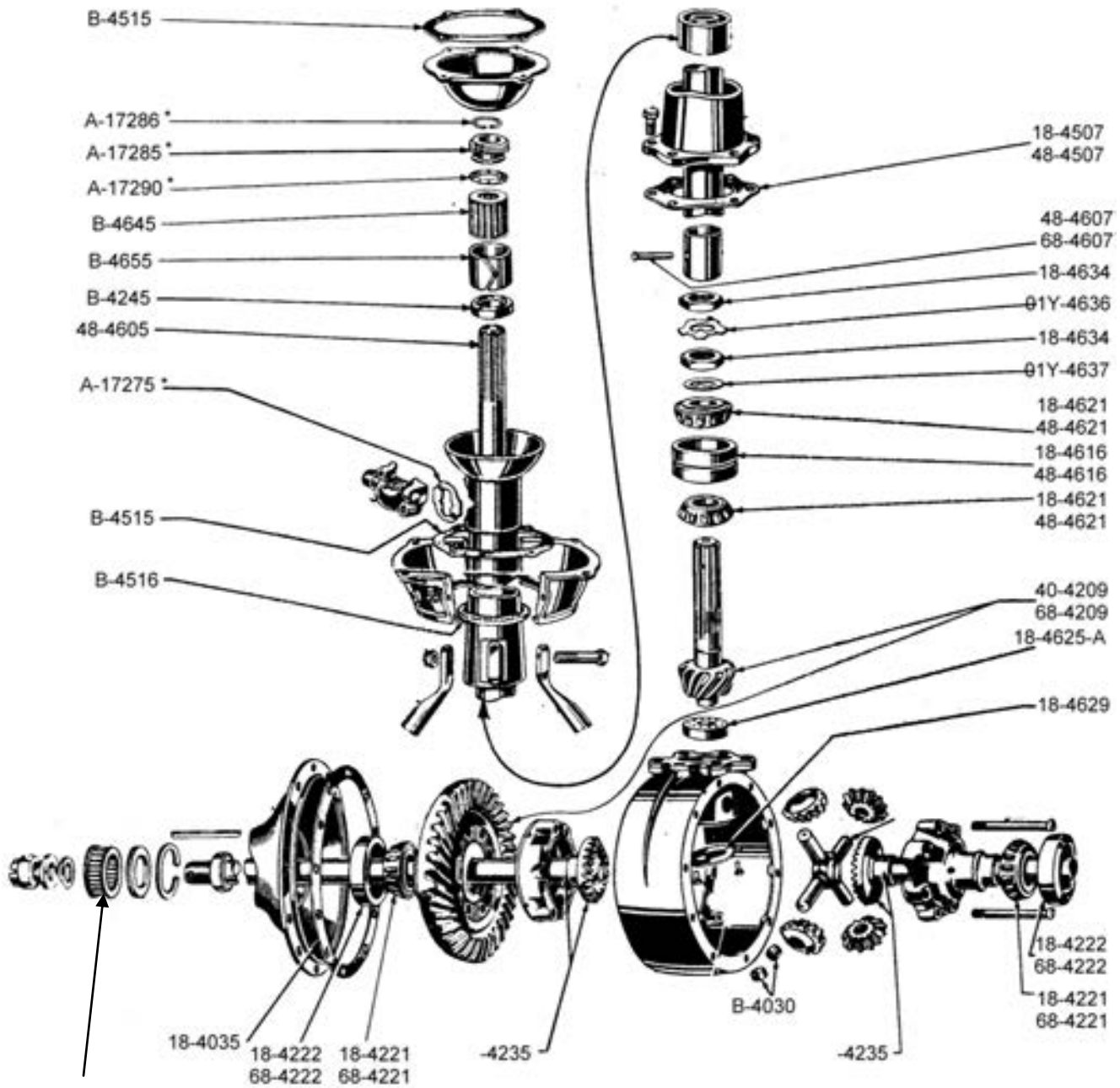

Rear Wheel Hub Parts.
See Wheel Section
For Part Numbers

TYPICAL REAR AXLE ASSEMBLY

1935-48 CAR & 1935-41 PICKUP

**WE ALSO OFFER WHEEL PULLERS,
SEE RESTORATION ITEMS IN BACK OF
PAGES OF CATALOG.**



For proper lubrication we
Recommend 600W oil, 2 3/4
pints required for rear end.
1 QT bottle.
See page 151 for pricing

EXHAUST SYSTEM BRACKETS AND CLAMPS

A-5251-E Clamp (2 piece) exhaust pipe to manifold 4 cylinder28-34 12.00 ea



48-5200-S Exhaust brackets & clamps, complete set for V835-38 30.00 set



18-5251



48-5260



48-5256



48-5259



48-5252

48-5200-S 1935-1938 EXHAUST BRACKET & CLAMP SET

Clamps not sold individually

99A-5261 Bracket, use at muffler outlet or end of tail pipe. 1 1/2"39-48 15.00 ea

99A-5261-B Bracket, NORSE, may be used at muffler outlet or end of tail pipe with possible modification39-48 N/A

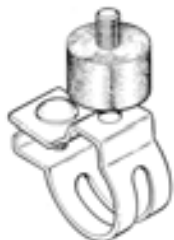

99A-5261



99A-5261-B

78-5283/4 Muffler clamp bushing kit, 3/8" inside diameter*, by Drake....37-39 15.00 kit

Each kit has (4) pair of rubber grommets, (4) have internal sleeves with inside diameter as stated.



78-5283/4

MUFFLERS

40-5230 V8, 85 HP cars & pickups 32-34 ASK
 48-5230-A V8, 85 HP cars & pickups 35-38 ASK
 52-5230 V8, 60 HP cars 37-40 ASK
 91A-5230 V8, 85 & 95 HP 1939-40 cars & 1941 pickups 39-41 ASK
 11A-5230 V8 cars1941 ASK
 2GA-5230-A 6 & 8 cylinder, cars 42-48 ASK

Above are replacement mufflers with flat ends as pictured below.



18-5230, 48-5230-A, 91A-5230

FRONT EXHAUST 'Y' PIPES

B-5250 4 Cylinder Model B 32-34 ASK
 18-5245 V8, cars & pickups 1932 ASK
 40-5245 V8, cars & pickups 33-34 ASK
 48-5245 V8, 85 HP cars & pickups 35-36 58.00 ea
 91A-5245 V8, 85 HP 1937-40 cars & 1937-1941 pickups 37-41 ASK
 11A-5245 V8-85-95 HP cars ONLY 1941 ASK
 21A-5246 V8, 85-95 HP cars 42-48 58.00 ea
 7RC-5245 V8, pickup, F-1 1/2 ton, F-2 commercial 42-52 ASK



CROSS OVER PIPES

18-5267 V8, cars & pickup 1932 ASK
 40-5267 V8, cars & pickup 33-34 ASK
 48-5267 V8, cars & pickup 35-36 34.00 ea
 78-5267 V8, cars & pickup 37-41 37.00 ea
 51A-5267 V8, cars 42-48 34.00 ea
 59C-5267 V8, pickup 42-53 ASK



TAIL PIPES

B-5255-S V8, 2 pieces, cars & pickup 1932 N/A
 40-5255-S V8, 2 pieces, cars & pickup 33-34 N/A
 48-5255 V8, cars & pickup 35-38 75.00 ea
 91A-5255 V8, 39-40 cars & pickup 39-41 65.00 ea
 6A-5255 V8, cars, 42-48 75.00 ea

EXHAUST DEFLECTORS & TIPS

Polished Stainless Steel

51A-18259-F "FORD" script embossed 17.50 ea
 51A-18259-V8 "V-8" embossed 17.50 ea
 51A-18259-P Plain 17.50 ea



51A-18259-F



51A-18259-V8

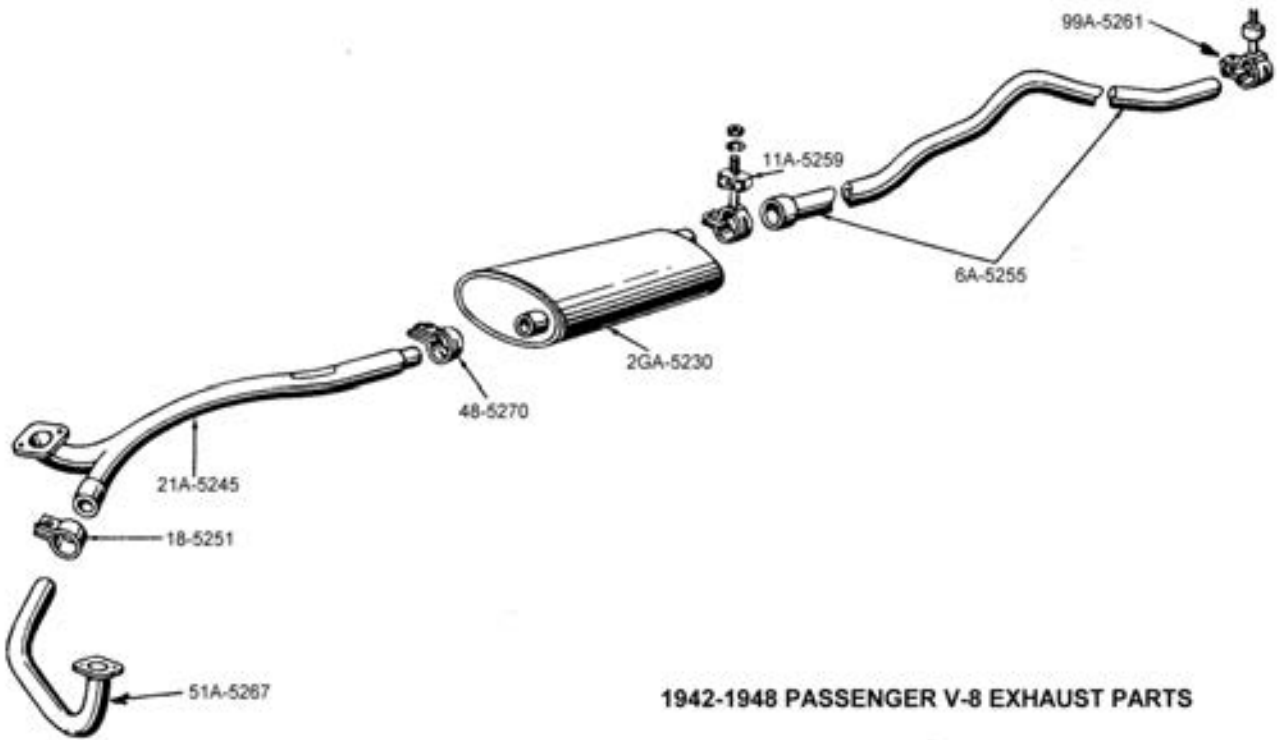
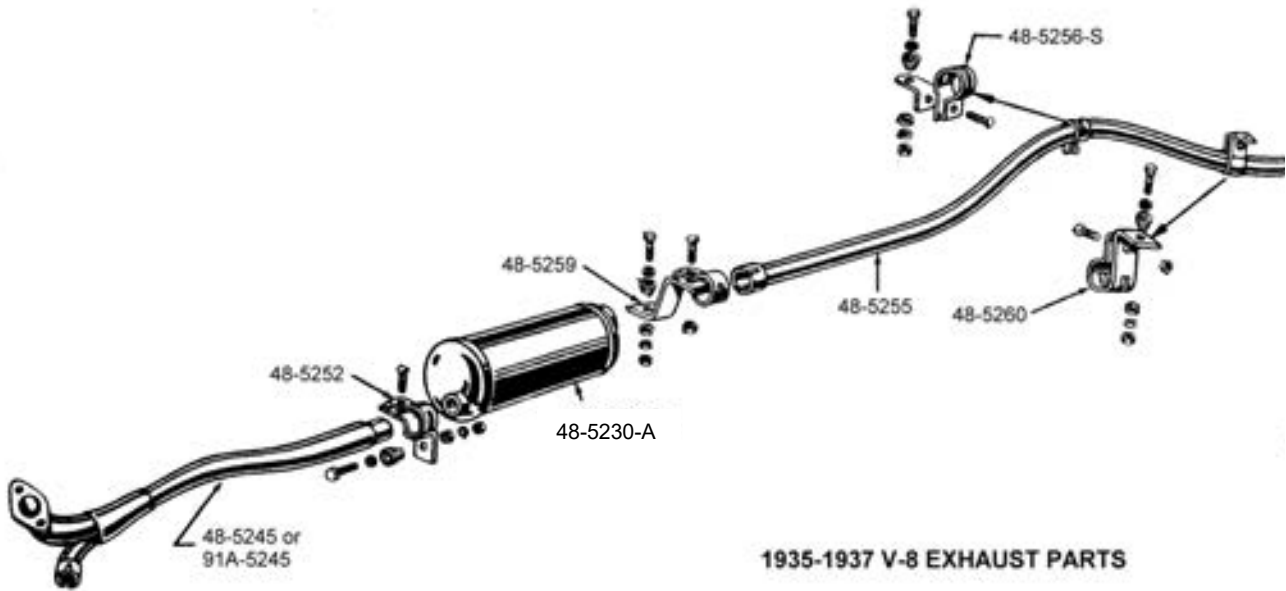

**NOTE: NOT ALL PARTS SHOWN ABOVE ARE AVAILABLE.
CHECK LISTING OF PARTS ON PREVIOUS PAGE FOR AVAILABILITY**

COMPLETE ENGINE OVERHAUL GASKET SETS

- Model B, 4 Cylinder**
- B-6008-C With copper head gaskets..... 32-34 130.00 set
 B-6008-S With steel (Felpro) head gaskets . 32-34 80.00 set
- 8 Cylinder, 21 Stud, 85 HP**
- 18-6008-C With copper head gaskets..... 32-37 175.00 set
 18-6008-S With steel clad head gaskets 32-37 125.00 set
- 8 Cylinder, 24 Stud, 90 HP**
- 91A-6008-C With copper head gaskets..... 38-42 135.00 set
 91A-6008-S With steel head gaskets *..... 38-42 100.00 set
- 8 Cylinder, 24 Stud, 90 HP, 95 & 100 HP**
- 59A-6008-C With copper head gaskets..... 39-48 135.00 set
 59A-6008-S With steel head gaskets *..... 39-48 105.00 set
- 8 Cylinder, 239 cu in, Flathead**
- 8BA-6008-C With copper head gaskets..... 48-53 150.00 set
 8BA-6008-S With steel head gaskets *..... 48-53 80.00 set
- *These gaskets are fibrous type*



Typical Engine gasket set (59A-6008-S Shown)

**INDIVIDUAL ENGINE GASKETS
 CYLINDER HEAD GASKETS**

- B-6051-C Copper head gasket, 4 cylinder, Model B..... 32-34 58.00 ea
 B-6051-S Graphite head gasket, 4 cylinder, Model B 32-34 46.00 ea

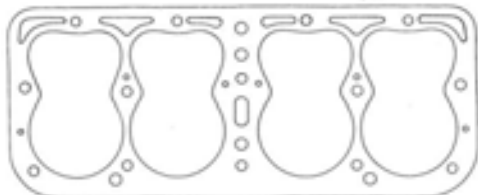

B-6051

- 40-6051-C Copper head gasket, 85 HP, 21 stud 32-37 52.00 ea
 40-6051-S Steel clad head gasket, 85 HP, 21 stud 32-37 20.00 ea
 40-6051-K Graphite head gasket, 85 HP, 21 stud 32-37 46.00 ea

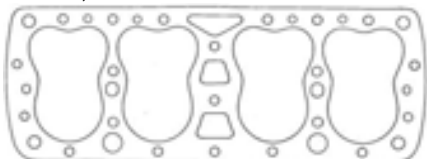

40-6051

CYLINDER HEAD GASKETS - continued

- 91A-6051-C Copper head gasket, 85-90 HP, 3 1/16" bore, 24 stud 38-42 60.00 ea
 91A-6051-S Steel (fiber style) head gasket, 85-90 HP, 3 1/16" bore, 24 stud . 38-42 30.00 ea

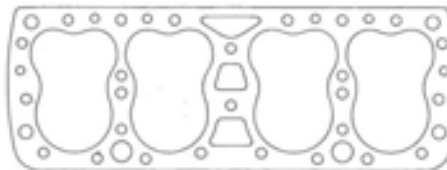

91A-6051

- 59A-6051-C Copper head gasket, 95-100 HP 3 3/16" bore, 24 stud 39-48 52.00 ea
 59A-6051-S Steel (fiber style) head gasket, 95-100 HP, 3 3/16" bore, 24 stud 39-48 25.00 ea

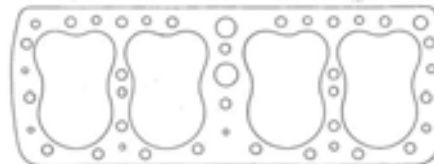

59A-6051

- EAB-6051-S RH steel head gasket * 49-53 20.00 ea
 EAB-6083-S LH steel head gasket * 49-53 20.00 ea
 EAB-6051-C RH copper head gasket..... 49-53 55.00 ea
 EAB-6083-C LH copper head gasket 49-53 55.00 ea

**These are fiber style gaskets*

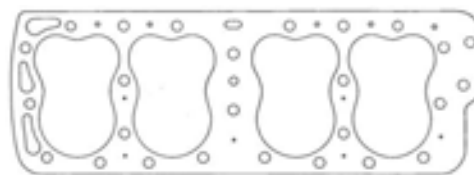

EAB-6051

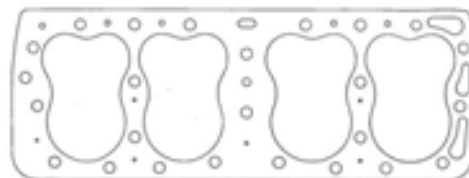

EAB-6083

INDIVIDUAL ENGINE GASKETS

TIMING COVER GASKET

- B-6018 Side gasket, 4-cyl 28-34 1.00 ea
 B-6020 Front gasket, 4-cyl 28-34 1.00 ea
 18-6020 All V8 32-53 5.00 ea



B-6018

B-6020

18-6020

NOTE: COPPER HEAD GASKETS ARE NOT RECOMMENDED FOR USE WITH ALUMINUM HEADS

INDIVIDUAL ENGINE GASKETS continued

VALVE COVER (INTAKE MANIFOLD) GASKETS

B-6521	4 cylinder, Model B & C	32-34	12.00 ea
40-6521	85 - 95 HP, V8.....	33-48	13.00 ea
8BA-6521	239 cu inch, V8	49-53	13.00 ea



B-6521



40-6521



8BA-6521

FRONT & REAR MAIN SEALS

A-6700	Front packing, original type	28-53	3.00 ea
A-6700-MR	Front crank seal, 1 piece type ..	28-53	15.00 ea
91A-6347	Upper or lower packing, rear main seal, original rope style	39-48	3.00 ea
91A-6347-KIT	Upper & lower rear main seal graphite rope style, 2 pieces.....	39-53	24.00 set
1BA-6701	Upper or lower packing, rear main seal, rope style	49-53	2.50 ea



A-6700



A-6700-MR



91A-6347-KIT

OIL PAN GASKET SETS

B-6781	4 cylinder, Model B	32-34	16.00 set
18-6781	V8	32-34	20.00 set
48-6781	V8, 85 & 95 HP	35-48	18.00 set
8BA-6781	239 cu inch, V8	49-53	19.75 set
7HA-6710	6 cylinder "H".....	47-48	25.00 set
7HT-6698	Oil pan plate clean-out gasket.....	49-53	4.75 ea



48-6781



7HT-6698

EXHAUST MANIFOLD GASKETS

A-5251-ES	Manifold to exhaust, 4 cylinder, copper.....	28-34	4.00 ea
A-9433-C	Manifold to engine, copper 4 cyl ..	28-34	15.00 set
B-9440-S	Manifold gland ring set, 4 cylinder, steel.....	28-34	4.00 set
B-9447-C	Manifold to carburetor, 4 cyl.....	28-34	2.75 ea
18-9433	Manifold to exhaust, V8	32-53	.75 ea
18-9433-S	Manifold to engine, same as above except set of 8, V8	32-53	6.00 set
C1SZ-9450	Manifold to exhaust, V8	49-64	2.00 ea



A-9433-C



A-5251-ES



18-9433



C1SZ-9450

ENGINE & TRANSMISSION MOUNTS

B-5089-B	Rear, car & pickup, 4 & 8 cylinder	1932	50.00 ea
40-5089-B	Rear, car & pickup	33-34	50.00 ea
48-5089	Rear, car & pickup	35-36	50.00 ea
41A-6023	Engine mount adaptor, to mount 1937-48 V8's into 32-36 cars & pickups	32-36	45.00 pr
21A-6068	Rear, 42-48 cars & 42-52 pickups, 6 & 8 cylinder.....	42-48	29.00 ea
B-6038-S	Front motor mount kit, small hole, 2 kits required		
	Replacement type.....	32-36	16.00 kit
	By Bob Drake *	32-36	24.00 kit
78-6038-S	Front motor mount kit, large hole, also for 1937-1941 transmission mount, 4 kits required		
	Replacement type.....	37-48	16.00 kit
	By Bob Drake *	37-48	24.00 kit

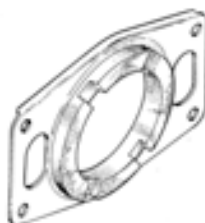

B-5089-B



40-5089-B



48-5089



41A-6023



21A-6068

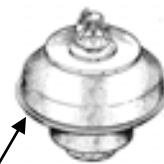

B-6038-S
78-6038-S

One kit shown in illustration

* Motor mounts by Bob Drake are designed as original with metal ring supporting OD of larger diameter rubber (B-6038-C. Although replacement style does not have this support ring it is well design for proper function. Bob Drake mounts sold only as complete kits.

Individual components of replacement mounts

B-6038-C	Upper rubber mount	32-48	7.00 ea
B-6039-A	Lower rubber mount	32-48	5.00 ea
B-6047	Motor mount bolt 3" standard length.....	32-48	4.00 ea
B-6047-B	Motor mount bolt, 3 1/4" long with nut Use for custom applications when extra length needed	32-48	10.00 ea
B-6048	Large washer, 7/8" hole.....	32-36	2.00 ea
78-6048-A	Large washer, 1 1/8" hole.....	37-48	2.00 ea
34031-S	Bolt nut, replacement.....	32-48	1.00 ea

Not available B-6038-C B-6039-A

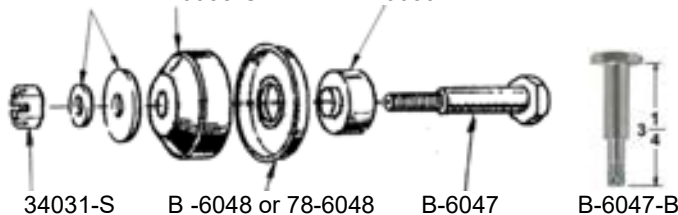

34031-S

B-6048 or 78-6048

B-6047

B-6047-B

CYLINDER HEAD NUT & WASHER

351025	Cylinder head nut, V8	32-48	.35 ea
351025-S	Cylinder head nut, V8, set of 48 ...	32-53	15.00 set
351020-S	Cylinder head washer, use with aluminum head, set of 50	32-53	13.50 set



351025



351020-S

CYLINDER HEAD STUDS - (Individual)

B-6066	3.48" long, 4 cylinder, 14 req'd.....	1932	2.50 ea
40-6065	2.34" long, (1932-1937, 10 req'd), (1938-1948, 16 req'd)	32-48	3.00 ea
40-6066	2.90" long, (1932-1936, 10 req'd), (1937, 8 req'd), (1938-1941, 4 req'd).....	32-48	2.50 ea
40-6067	3.59" long, (1932-1936, 22 req'd).	32-36	3.50 ea
48-6067	3.09" long, (28 req'd except 1937 24 req'd).....	35-48	3.50 ea



CYLINDER HEAD STUD / NUT SETS

Below sets include head nuts

B-6066-S	Includes (14) B-6066, & (14) 351025 4 cyl. Model B	1932	22.00 set
40-6066-ST	Includes (10) 40-6065, (10) 40-6066, (22) 40-6067 & (42) 351025 nuts, 21 stud engine	32-36	90.00 set
78-6066-ST	Includes (10) 40-6065, (8) 40-6066 & (24) 48-6067 & (42) 351025 nuts, 21 stud engine	1937	90.00 set
81A-6066-ST	Includes (16) 40-6065, (4) 40-6066, (28) 48-6067 & (48) 351025 nuts 24 stud engine	38-48	90.00 set

CYLINDER HEAD BOLTS- 8BA ENGINES

8BA-6065	1.94" long (20 required)	49-53	2.50 ea
8BA-6066	2.62" long (28 required)	49-53	2.50 ea



CHROME NUT COVERS

CNC-6062-7/16	7/16" across flats	32-48	1.00 ea
CNC-6062-1/2	1/2" across flats	32-48	1.00 ea
CNC-6062-9/16	9/16" across flats	32-48	1.00 ea
CNC-6062-9/16-S	9/16" set of 20 for intake	32-48	12.00 set
CNC-6062-5/8	5/8" across flats	32-48	1.00 ea
CNC-6062-11/16	11/16" across flats	32-48	1.00 ea
CNC-6062-11/16-S	11/16" set of 50 for head	32-48	35.00 set



INTAKE MANIFOLD WASHERS

351242-S	Intake manifold washer, set of 20	32-48	6.00 set
----------	--	-------	----------



FRONT TIMING COVERS & TIMING PIN

18-6019	All 85 & 95 HP, V8	32-41	26.00 ea
B-6023	Front cover timing pin, Model B ...	1932	2.75 ea

EXHAUST MANIFOLD STUDS, NUTS & WASHERS

B-9443	Manifold stud washer, heavy, cup shaped, 4-cylinder	1932	1.00 ea
88393	Manifold to muffler pipe stud, V8	37-48	1.50 ea
33816-S	Manifold to muffler pipe stud nut, brass, V8	37-48	1.00 ea
351025	Manifold nut as above except steel	37-48	.35 ea



88393



33816-S

PISTON SETS

BB-6108-S	With fitted pins, 4 cylinder, Model B, sizes: Std, .020, .030, .040, .060, .080, .100, .125	1932	ASK
<i>Use piston ring B-6149</i>			
40-6108-S	3 1/16" dia. with fitted pins, flat head, aluminum 85 HP. Sizes: Std, .020, .030, .040, .060 ..	32-37	ASK
<i>Use piston ring 40-6149</i>			
01T-6108-S	3 1/6" dia. with fitted pins, dome top, aluminum, 85 HP. Sizes: Std, .020, .030, .040, .060 ..	32-42	ASK
<i>Use piston ring 01T-6149</i>			
8BA-6108-S	3 3/16" dia. with fitted pins, dome top, aluminum, 95 HP, solid skirt, Sizes: Std, .020, .030, .040, .060, .080	39-48	235.00 set
<i>Use piston ring 8BA-6149</i>			



01T-6108

PISTON RINGS

B-6149-S	4 cylinder, Model B, 3 ring type, sizes: Std, .020, .030, .040, .060, .080	1932	ASK
<i>Ring set fits piston BB-6108</i>			
40-6149-S	85 HP, V8, 3 ring type, sizes: Std, .020, .030, .040, .060, .080 ..	32-36	
<i>Not available changed to 01T-6149 ring set</i>			
01T-6149-S	85 HP, V8, 4 ring type, sizes: Std, .020, .030, .040, .060, .080 ..	32-42	75.00 set
<i>Ring set fits piston 40-6108 & 01T-6108</i>			
8BA-6149-S	95 HP, V8, 4 ring type, solid skirt piston, sizes: Std, .020, .030, .040, .060, .080	39-53	75.00 set
<i>Ring set fits piston 8BA-6108</i>			



8BA-6149-S

PISTON PINS & CLIPS

01A-6135-S	Piston wrist pin, standard, 85 HP, 3 1/16" bore.....	38-42	ASK
48-6135	Piston wrist pin 3 1/16" bore.....	38-42	ASK
49T-6135	Piston wrist pin, standard, 95 HP, 3 3/16" bore.....	39-48	ASK
78-6140	Piston pin snap ring, all V8's except 60 HP	32-48	1.00 ea

01A-6135 78-6140 Rod Bushing Rod Bearing



CONNECTING RODS, NUTS & BEARINGS

18-6212	Connecting rod nut.....	32-48	1.00 ea
---------	-------------------------	-------	---------



Note: Not all of the rod bearings listed in this section may be available. Please call to check availability prior to order!

B-6200	Rod, 4 cylinder, exchange only , sizes: Std, .010, .020, .030, .040.....	32-34	ASK
--------	---	-------	-----

***Above connecting rods are exchange only and do not include bearings. (See below for rod bearings)**

Your exchange must be acceptable and complete with the cap, bolts, and nuts. If we do not have your exchange prior to shipping, an exchange fee of \$25.00 per rod will be billed. This core charge will be refunded upon receipt of your acceptable exchange.

B-6207	Rod bushing, 4 cylinder	32-34	2.00 ea
18-6207	Rod bushing, 85 HP, V8, 1.34"	32-42	4.00 ea
21A-6207	Rod bushing, 85 & 95 HP, V8	42-53	2.75 ea
21A-6207-0	Rod bushing, 85 & 95 HP, V8, oversize.....	42-53	ASK
48-6211-S	Rod bearing, standard, .003, .010 .020 OR .030 w/lips, V8, 1.999	32-38	ASK
81A-6211-S	Rod bearing, 85 HP, V8, standard without lips, 1.999" *	39-41	ASK
81A-6211-10	Rod bearing, 85 HP, V8, .010 undersize, without lips *	39-41	ASK
81A-6211-20	Rod bearing, 85 HP, V8, .020 undersize, without lips *	39-41	ASK
81A-6211-30	Rod bearing, 85 HP, V8, .030 undersize, without lips *	39-41	ASK
99T-6211-S	Rod bearing, 95 HP, V8, standard, 2.139" *	39-48	ASK
99T-6211-02	Rod bearing, 95 HP, V8, .002 undersize *	39-48	ASK
99T-6211-10	Rod bearing, 95 HP, V8, .010 undersize *	39-48	ASK
99T-6211-20	Rod bearing, 95 HP, V8, .020 undersize *	39-48	ASK

CONNECTING ROD BEARINGS continued

99T-6211-30	Rod bearing, 95 HP, V8, .030 undersize *	39-48	ASK
99T-6211-40	Rod bearing, 95 HP, V8, .040 undersize *	39-48	ASK
0BA-6211-10	Rod bearing, 8BA engine .010 * ..	49-53	25.00 pr
0BA-6211-20	Rod bearing, 8BA engine .020 * ..	49-53	25.00 pr
0BA-6211-30	Rod bearing, 8BA engine .030 * ..	49-53	25.00 pr
0BA-6211-40	Rod bearing, 8BA engine .040 * ..	49-53	25.00 pr

*** These engine requires 4 pair of bearings**

CAMSHAFT REAR SMALL GEARS

18-6254-A	85 & 95 HP, round ID	32-41	12.00 ea
18-6254-B	85 & 95 HP, 3/8", flat spot on ID	32-53	33.00 ea

CAMSHAFT TIMING GEARS

B-6256-A	4 cylinder, standard, fiber*	1932	49.00 ea
----------	------------------------------------	------	----------

**Above gear is heavy duty laminated & stronger than fiber*

18-6256	56 teeth, fiber, press-on	32-34	40.00 ea
48-6256-A	44 teeth, fiber, press-on	35-40	20.00 ea
91A-6256	44 teeth, aluminum, bolt-on	39-48	48.00 ea
8BA-6256-ALUM	Aluminum	49-53	55.00 ea
52-6256	60 HP, V8, fiber, press-on	37-40	30.00 ea

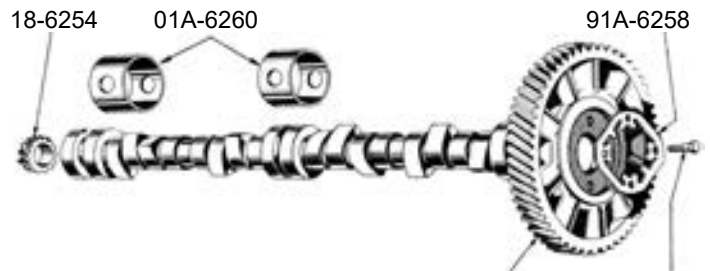

Camshaft Timing Gear 350400-S

CAMSHAFT BOLTS & WASHERS

350400-S	Camshaft gear lock ring washer bolt.....	39-48	2.00 ea
91A-6258	Camshaft gear lock ring washer ..	39-48	4.00 ea

CAMSHAFT LOCK NUTS & BEARINGS

B-6259	Gear lock nut, 4 cylinder	1932	5.00 ea
01A-6260-S	Bearings, 3 pieces, standard, V8	32-53	37.00 set
01A-6260-010	Bearings, 3 pieces, .010 oversize OD, V8.....	32-53	50.00 set
B-6275-S	Camshaft thrust plunger and spring.....	1932	3.50 set
11A-6280	Distributor to camshaft adapter, (extension that fits onto early camshaft to use with 1942-1948 distributor).....	32-41	12.00 ea



11A-6280

CRANKSHAFT GEARS & KEYS

B-6306	4 cylinder, steel.....	1932	11.25 ea
18-6306	28 tooth, V8, steel.....	32-35	25.00 ea
48-6306	22 tooth, V8, steel.....	35-48	29.00 ea
8BA-6306	V8 steel.....	49-53	25.00ea
52-6306	60 HP, V8, steel.....	37-40	26.00 ea
74153-S	Woodruff key, 85 or 95 HP.....	38-53	2.00 ea
74156-S	Woodruff key, 85 HP.....	32-37	1.00 ea

CRANKSHAFT OIL SLINGER

Fits front of crankshaft

B-6310	4 cylinder.....	1932	4.00 ea
40-6310-A	85 HP, V8.....	33-37	2.50 ea
81A-6310	85 & 95 HP, V8.....	38-48	2.50 ea

CRANKSHAFT PULLEYS

B-6312-A1	1 piece, 4 cylinder *.....	1932	23.00 ea
B-6312-B2	2 piece, 4 cylinder *.....	1932	31.00 ea

* Note: Use A1 if engine out of car, B2 if engine in car

CRANKSHAFT RATCHETS

B-6319	All engines.....	32-36	16.00 ea
52-6319	60 HP engines.....	37-40	5.00 ea
81A-6319	85 & 95 Hp engines NOS.....	38-48	10.00 ea

CRANKSHAFT MAIN BEARING SET

68-6330	85 HP, V8, 21 stud engine, 2.39" journal, sizes: Std, .010, .020, .030, .040.....	36-38	ASK
81A-6330	85 & 95 HP, V8, 24 stud engine, 2.498" journal, sizes: Std, .002, .010, .020, .030, .040.....	38-48	95.00 set

REAR MAIN BEARING OIL SLINGERS

78-6335	Upper, 85 HP, V8, with rear single slinger, V shaped groove... 37-42	40.00 ea
78-6336	Lower, 85 HP, V8, with rear single slinger, V shaped groove... 37-42	15.00 ea
91A-6335	Upper, V8, with U shaped groove for seal..... 39-48	45.00 ea
19B-6336	Lower, V8, U shaped groove for seal..... 39-48	33.00 ea

MAIN BEARING CAP BOLTS, STUDS & NUTS

48-6345	Stud, 3.07".....	32-36	Disc
18-6345	Bolt, 4.59".....	32-36	Disc
68-6345	Stud, 3.30".....	37-48	Disc
B-6340/46-S	Shim set, Model B, 6 pieces.....	32-34	10.00 set
B-6700	Oil pan front packing.....	32-53	1.25 ea
B-6347	Front & center bolt, 4 cylinder.....	32-36	2.50 ea
B-6348	Bearing cap bolt nut.....	32-48	1.00 ea

FLYWHEEL RING GEAR & PARTS

B-6376-S	Flywheel mounting bolt, hole in head, set of 4.....	32-48	14.00 set
B-6384	Flywheel ring gear, 85 & 95 HP engines.....	32-48	25.00 ea
8BA-6384	Flywheel ring gear, USA made....	49-53	27.00 ea
B-6387	Dowel, flywheel to crankshaft.....	32-48	4.00 ea
18-6397	Dowel, flywheel housing to transmission.....	32-48	2.50 ea



Engine enamel offered in "Restoration Items" section of catalog in back pages

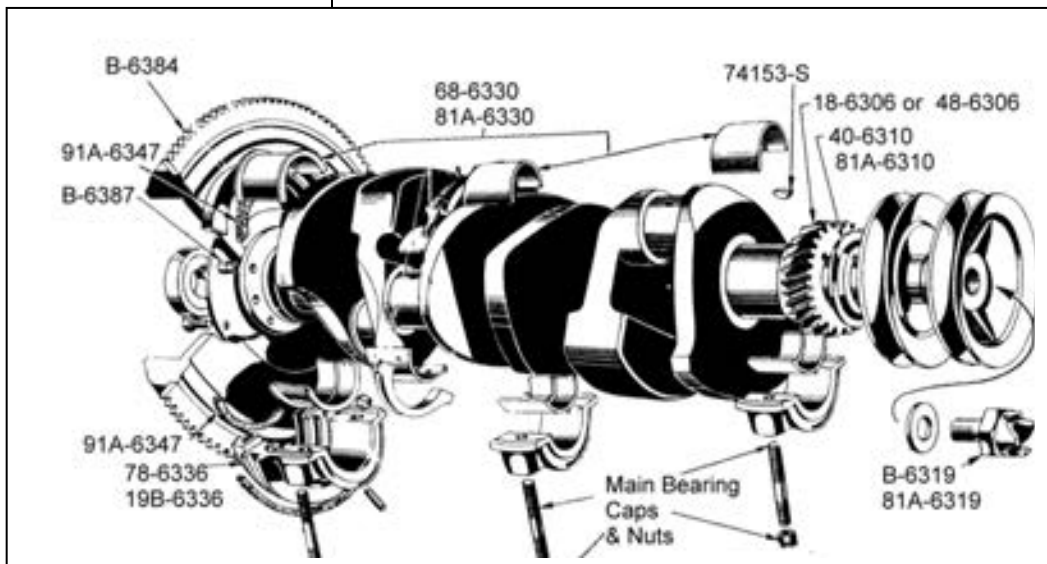

CRANKSHAFT MAIN BEARING SET continued

1BA-6330	85 & 95 HP, 8BA engine, 2.498" journal, sizes: Std, .010, .020, .030, .040.....	49-53	90.00 set
----------	---	-------	-----------

OIL PRESSURE SENDING UNITS

48-9278	50 lbs V8 & 6 cylinder.....	35-42	50.00 ea
41A-9278	80 lbs.....	35-53	40.00 ea



OIL PAN DRAIN PLUGS & GASKETS

B-6730	Drain plug, 3/4-24 x 5/8.....	32-38	2.50 ea
B-6730-M	Drain plug as above except with magnet, 3/4-24 x 5/8.....	32-38	5.75 ea
52-6730	Drain plug 1 1/2-30 x 5/8.....	39-48	10.00 ea
8HA-6730	Drain plug w nylon gasket, 7/8-16.....	49-56	6.00 ea
B-6734	Gasket, fiber, use with B-6730.....	32-38	1.00 ea
A-6734-C	Gasket as above except copper..	32-38	4.00 ea
52-6734	Gasket, fiber, 1 1/2" ID.....	35-48	1.75 ea
8HA-6734	Gasket, fiber, use with 8HA-6730.....	49-53	1.50 ea



B-6730



52-6730



Typical drain plug gasket

TAPPETS

A-6500-DL	Adjustable, 4 cyl, single lock....	1932	72.00 set
91A-6500-AJ	Adjustable, V8, solid	32-53	14.00 ea
91A-6500-AJST	As above but set of 16	32-53	195.00 set
91A-6500-AJJB	Adjustable, V8, hollow "Johnson style"	32-53	15.00 ea
91A-6500-AJJBST	As above but set of 16	32-53	240.00 set
91A-6500-AJW	Adjustable tappet wrench	32-53	10.00 set



Valve With Split Guides

91A-6500-AJW



Valve With Solid Guides

COMPLETE VALVE OVERHAUL KIT

8BA-6505/10-KIT	32-53	219.00 kit
-----------------	-------	-------	------------

Above kit, includes (16) each of 8BA-6510 solid guides, 8BA-6505 valves, 40-6512 guide retainers, 78-6513 valve springs, 8BA-6514 spring keepers, 7HA-6518 valve lock key, & (8) 8BA-6571 O-ring seals. Above components also sold separately below

VALVES

B-6505	Exhaust & intake, stainless steel, Model B, 4 cylinder	1932	10.00 ea
11T-6505	Exhaust, & intake 85 & 95 HP, V8, use with split valve guides	32-48	17.50 ea
8BA-6505	Exhaust & intake, 85 & 95 HP, use with solid valve guides *	32-50	7.00 ea

VALVE GUIDES & RETAINER

B-6510	Guide, split type, cast iron, Model B, 4 cylinder, 8 pair req'd... ..	1932	8.50 pr
40-6510	Guide, split type, 85 & 95 HP, V8, 16 pair required	33-53	9.75 pr
8BA-6510	Guide, solid, 85 & 95 HP, V8, 16 required.....	33-53	4.50 ea
40-6512	Retainer, 85 & 95 HP, horseshoe shape	32-53	1.50 ea

VALVE SEAL

8BA-6571-S8	Valve guide seal, set of 8 (used on intake valves & with 8BA 6505 valve guides only).....	48-53	4.00 set
-------------	---	-------	----------

VALVE SPRINGS & RETAINERS

B-6513	Spring, Model B, 4 cylinder	1932	.75 ea
78-6513	Spring, 85 & 95 HP	32-53	2.50 ea
40-6514-B	Retainer, 85 & 95 HP, for split valve guides	32-48	.75 ea
8BA-6514	Retainer, for solid valve guides*....	33-50	1.50 ea
7HA-6518	Valve locks for 8BA-6505 straight valves *.....	33-50	.75 pr

* Note: these items will also fit 51-53 if above valves & guides if purchased as set

VALVE COVER OIL BAFFLE

48-6524	85 & 95 HP, V8.....	35-48	8.00 ea
---------	---------------------	-------	---------



OIL DIP STICK & TUBE

48-6750	Dip stick, V8, all	35-48	14.00 ea
48-6754-B	Dip stick tube, 8 1/4" long	35-48	11.00 ea

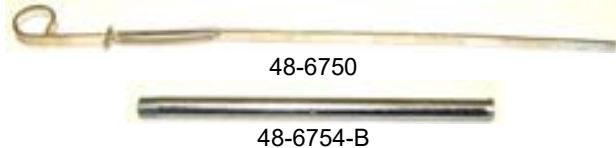

48-6750

48-6754-B

DIP STICK TUBE BOSS & GASKET KITS

48-6751	Die cast zinc boss with gasket & rivets for installation	35-46	32.75 kit
59A-6751	Die cast zinc boss with oil return hole, gasket & rivets for install	47-48	32.75 kit
48-6753-KT	Gasket ONLY & (3) threaded rivets with lock nuts for boss installation	35-48	5.00 set
8BA-6753-KT	Gasket ONLY & rivets set as above except for 8BA engine.....	49-53	5.00 set



48-6751-KT



59A-6751-KT



48-6753-KT

OIL FILTER & ZINC ADDITIVE

7HA-6731	Oil filter element (cartridge) with gasket.....	40-53	14.00 ea
ZDDPLUS	Oil additive to add zinc to correct level in "Flathead" motors as required per original specs. 4 oz bottle which can be added at each oil change	28-53	11.00 ea



7HA-6731



ZDDPLUS

OIL PAN VENTILATOR TUBES

48-6756-A	4.98" long located at rear of cast iron valve cover	35-48	6.00 ea
48-6759	Front oil pan tube.....	35-48	4.75 ea

OIL BREATHER/FILLER CAP

48-6766-B	Oil breather/filler cap, black	35-48	20.00 ea
48-6766-C	Cap as above but chrome	35-48	24.00 ea
8BA-6766	Oil filler cap, 8BA engines	49-53	20.00 ea

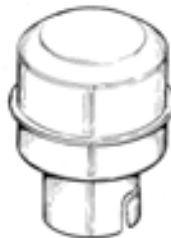

48-6766-B
48-6766-C



8BA-6766

ORDER & INFORMATION LINE 1- 508-278-3980 TOLL FREE 1-800-508-3980 Email: joesantique@charter.net

OIL PUMP ASSEMBLIES

- 8BA-6621-USA **New** oil pump assembly, short 80 lb pump body. USA 32-53 175.00 ea
 - 8BA-6600-HO **New** oil pump assembly, short body, 80 lb, Hi volume USA 32-53 ASK
 - HR-6600-A 80 lb pump as above by Drake 32-53 125.00 ea
- NOTE: To convert and use these pumps to replace a long body pump you will need oil pickup assembly 8RT-6615 and screen 68-6623 which are listed in next section**



8BA-6621-USA



HR-6600-A
8BA-6600-HO

OIL PUMP REBUILD PARTS

- B-6600-RKT Rebuild kit, 4 cylinder, Model B.... 1932 N/A
 - 18-6600-RKT Rebuild kit, 85 HP, for 50 lb "long body" pressure pump..... 32-40 N/A
- 18-6600-RKT above includes individual components below**
- 18-6608 Gear with long shaft, 50 lb pressure pump 32-42 N/A
 - 18-6610 Small gear, 50 lb pressure pump 32-42 19.00 ea
 - A-6612 Bushing, 85 & 95 HP, 4 cylinder, Model B, 2 required..... 32-48 3.50 ea
 - 18-6652 Gear, upper shaft end, 85 & 95 HP 32-48 6.25 ea
 - 18-6661 Retaining pin 32-48 N/A
 - 68-6626 Pickup tube gasket..... 32-42 N/A
 - 68-6628 Screen clip 32-48 2.50 ea

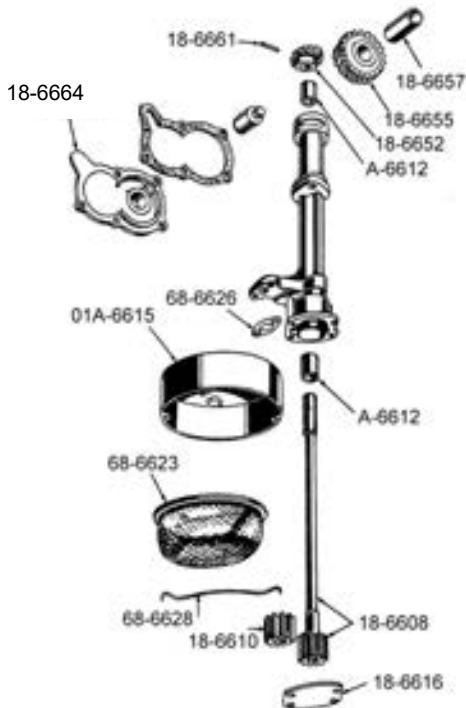

50# Pressure Oil Pump

OIL PUMP REBUILD PARTS continued

- 41A-6600-RKT Rebuild kit for 80 lb pressure pump with long body 35-48 ASK
- 41A-6600-RKT above includes individual components below**
- 41A-6608 Gear with long shaft, 80 lb pressure pump..... 35-48 N/A
 - 41A-6610 Small gear, 80 lb pressure pump 35-48 N/A
 - A-6612 Bushing, 85 & 95 HP, 4 cylinder, Model B, 2 required 32-48 3.50 ea
 - 18-6652 Gear, upper shaft end, 85 & 95 HP 32-48 6.25 ea
 - 41A-6626 Pickup tube gasket 32-42 1.50 ea
 - 18-6661 Retaining pin..... 32-48 N/A

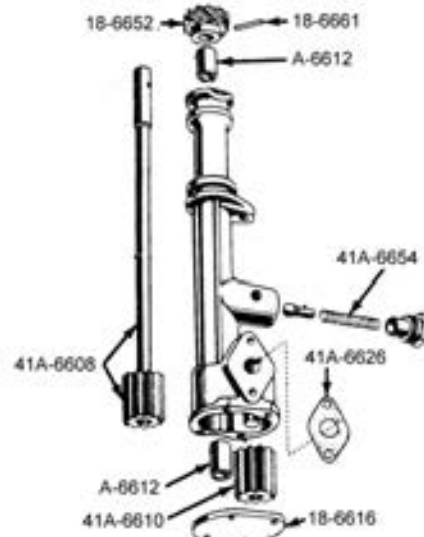

80# Pressure Oil Pump

- 8BA-6600-RKT Rebuild kit short body pump 49-53 95.00 kit

MORE OIL PUMP PARTS

- 01A-6615 Screen cover only 36-48 7.00 ea
- 8RT-6615 Oil pump pickup assembly, use with 8BA-6621 or 8BA-6600-HO oil pumps, includes screen clip 32-53 28.00 ea
- 41A-6623 Screen, 85 & 95 HP engines 35-53 15.00 ea
- 8BA-6628 Screen clip, fits 8RT-6615 pickup 32-53 2.50 ea



8RT-6615 & 8BA-6628



41A-6623

- 18-6616 Lower gear cover plate, 85 & 95 HP 32-48 8.00 ea
- B-6620 Retaining spring, 4 cylinder, Model B 1932 1.00 ea
- 01A-6654 Oil relief valve spring, 50 lb pressure pump (in block) 32-43 1.00 ea
- 41A-6654 Oil relief valve spring, 80 lb pressure pump (in block or pump) .. 32-48 2.00 ea
- 01A-6663 Oil relief valve plunger (in block).... 32-48 10.00 ea
- 18-6655 Idler gear with bushing 32-48 25.00 ea
- 18-6657 Idler gear bushing only 32-48 2.00 ea
- 18-6664 Drive cover with shaft 32-48 ASK
- 68-6666 Relief valve plug (in block)..... 35-48 7.00 ea

FLOOR SHIFT PARTS

B-7221	Shifter housing pin	32-47	1.50 ea
B-7223	Floor shift cover gasket only	32-48	3.00 ea
91A-7223-K	Floor shift gasket set, 3 spd, 3 pcs	32-52	7.00 set
B-7227	Floor shift lever spring.....	32-48	2.50 ea
A-7233/34	Tower plungers & spring set	28-37	6.00 ea
B-7248	Leather seal, 3 speed trans.....	32-47	4.00 ea
B-7249	Washer for above seal	32-47	2.50 ea

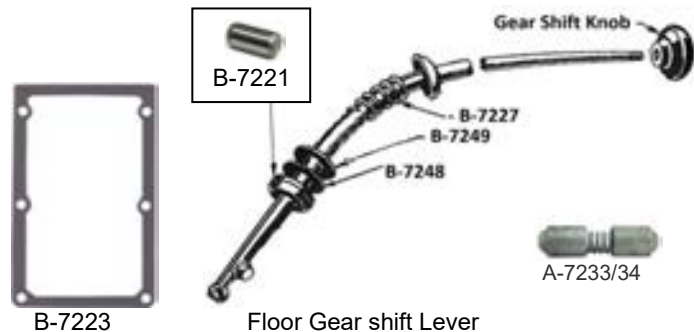

COLUMN SHIFT PARTS

01A-7223-K	Column shift gasket set, 3 pcs	40-48	6.50 set
01A-7223	Side cover gasket only	40-48	2.75 ea
01A-7219	Column shift fulcrum pin	40-48	3.00 ea



01A-7221	Gear shift lever pin only	40-48	6.00 ea
01A-7208	Shift lever spring only.....	40-48	1.25 ea
01A-7246	Shift lever grommet only	40-48	4.00 ea
01A-7221-K	Column shift lever kit. Includes (2) 01A-7221, (1) 01A-7208 & (1) 01A-7246 listed above.....	40-62	17.00 kit



01A-7288	Column shift cover oil seal	40-48	3.50 ea
01A-7302	Column shift lever assembly, second and high.....	40-48	24.00 ea
01A-7303	Column shift lever assembly, low and reverse.....	40-48	24.00 ea

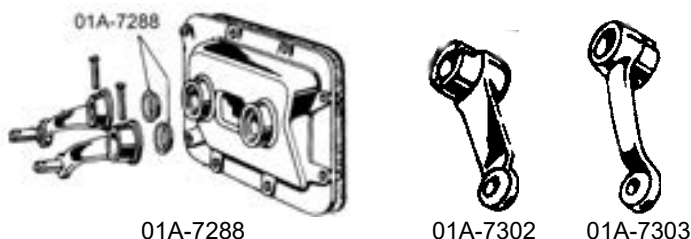

01A-7354-RK	Shift linkage repair kit including bushing, grommet & washer, 4 kits required per vehicle	40-48	4.75 kit
01A-7354-RK-D	Set of (4) 01A-7354-RK kits above with setting tool	40-48	28.50 kit



GEAR SHIFT KNOBS

Floor Shifts

A-7213-A	Black.....	32-36	4.00 ea
A-7213-B	Brown	32-36	5.00 ea
91C-7213	Black, pickups.....	35-48	15.00 ea
78-7213	Brown, embossed "V8"	37-38	12.00 ea
91A-7213	Yellow brown	1939	15.00 ea
99A-7213	Mercury, light peach	1939	15.00 ea



GEAR SHIFT KNOBS

Column Shifts

01A-7213-A	Sand, Standard	1940	10.00 ea
01A-7213-B	Maroon, Deluxe	1940	10.00 ea
09A-7213-B	Mercury, dark blue.....	1940	15.00 ea
11A-7213-A	Light tan *	1941	15.00 ea
21A-7213-A	Maroon *	1942	15.00 ea
21A-7213-B	Butterscotch - Deluxe & Super Deluxe *	1942	15.00 ea
51A-7213-A	Chocolate, Deluxe *	1946	15.00 ea
51A-7213-B	Metalic Blue-Gray *	1946	15.00 ea
51A-7213-C	Gray-Tan, 1946 Convertible, Wagon & Sportsman and 1947-1948 all styles *	46-48	15.00 ea
21C-7213	Black, pickups.....	42-47	10.00 ea

* Also used as cowl vent knob



Typical Column Shift Knob

GEAR SHIFT BOOTS & TRIM PLATE

GB-7000	Gear shift boot, black, 4 cylinder .	1932	4.00 ea
A-7001-GB	Boot trim plate, polished stainless steel, fits GB-7000 only	1932	12.00 ea
99A-7242-B	Gear shift boot, black, V8 32-39 cars & 32-47 pickups.....	32-47	12.00 ea
99A-7242-T	Gear shift boot, tan, V8 32-39 cars & 32-47 pickups.....	32-47	12.00 ea



UNIVERSAL JOINT & PARTS

B-7090	Universal joint assembly, 85-95 HP, original style with bushings.....	28-48	ASK
HB-7090	Universal joint as above except with needle bearings.....	28-48	99.00 ea
B-7095	Universal joint to main shaft bolt & washer set.....	28-48	2.00 ea
B-7084	Universal joint cross & bearing kit all cars and 32-41 pickups.....	32-48	44.00 kit
B7AZ-4635-A	Universal joint cross & bearing kit all pickups only.....	42-48	15.00 kit

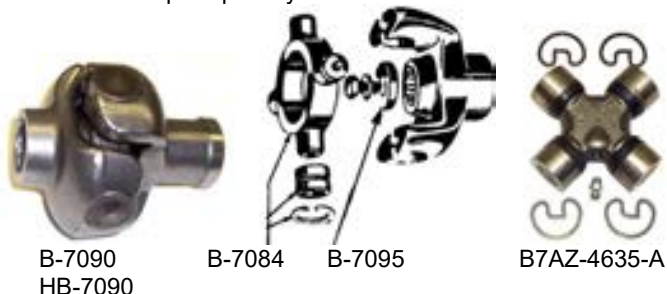

TRANSMISSION MAIN DRIVE GEAR

48-7017	Main drive gear, 16 teeth, 85 HP*.....	32-37	ASK
67-7017	Main drive gear, 14 teeth, 85 HP*.....	36-39	ASK
*Use with spur/helical cut clusters			
81A-7017	Main drive gear, 16 teeth, 85-95 HP**.....	38-48	185.00 ea
022A-7017	Main drive gear, 15 teeth, 85-95 HP**.....	40-48	185.00 ea
**Use with helical cut clusters			



TRANSMISSION MAINSHAFT (Output shaft)

B-7061	Main shaft, straight spline.....	32-38	139.00 ea
68-7061-A	Main shaft, 6 helical spline, 85 HP.....	1936	85.00 ea
68-7061-B	Main shaft, 16 helical spline, 85-95 HP.....	36-39	110.00 ea
51A-7061	Main shaft, without pin hole.....	39-48	ASK



TRANSMISSION LOW & REVERSE SLIDING GEARS

B-7100	Straight teeth.....	32-35	117.00 ea
67-7100	Straight teeth, pickups.....	36-38	115.00 ea
01A-7100	16 spline, 29 helical teeth.....	36-48	99.00 ea



01A-7100

TRANSMISSION SECOND SPEED GEAR & SLEEVE BUSHING

51A-7102	85-95 HP.....	39-50	150.00 ea
68-7104	Sleeve, bushing for original 81A-7102 gears.....	32-39	25.00 ea



81A-7102



68-7104

TRANSMISSION REVERSE IDLER GEARS & SHAFT

B-7140	Idler gear shaft.....	32-48	16.50 ea
B-7141	Idler gear, 85 HP, spur cut gear...	32-35	ASK
68-7141	Idler gear, 85-95 HP, helical gear.....	36-48	100.00 ea
B-7155	Idler gear lock pin.....	32-48	7.50 ea



B-7140



68-7141



B-7155

TRANSMISSION CLUSTER GEARS

67-7113	85 HP, 29 teeth, spur-helical.....	36-38	70.00 ea
68-7113	85-95 HP, 28-24-18-14.....	35-48	425.00 ea
022A-7113	95-110 HP, 29-24-18-14.....	39-48	425.00 ea



TRANSMISSION CLUSTER GEAR THRUST WASHERS

B-7119	Front cluster washer.....	32-48	5.50 ea
B-7129	Rear thrust washer, 5 prongs on OD **.....	32-35	8.50 ea
68-7129-A	Rear thrust washer, 4 prongs on OD **.....	32-35	5.00 ea
** For use with B, 48 & 67-7113 cluster gears			
68-7129-B	Rear thrust washer, 4 raised prongs on face of washer ***.....	36-48	15.00 ea
*** For use with 68 & 022A-7113 cluster gears			
8M-7129	Rear thrust washer, thick.....	40-48	10.50 ea
8M-7128	Rear thin washer, used with 8M-7129 washer above.....	40-48	5.50 ea



B-7119



B-7129



68-7129-A



68-7129-B



8M-7129



8M-7128

TRANSMISSION FILLER PLUG

353051-S	Plug as original (no magnet).....	32-48	1.75 ea
357993-S	Plug with magnet.....	32-48	8.00 ea



MAGNET

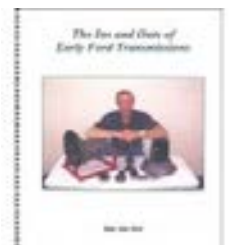
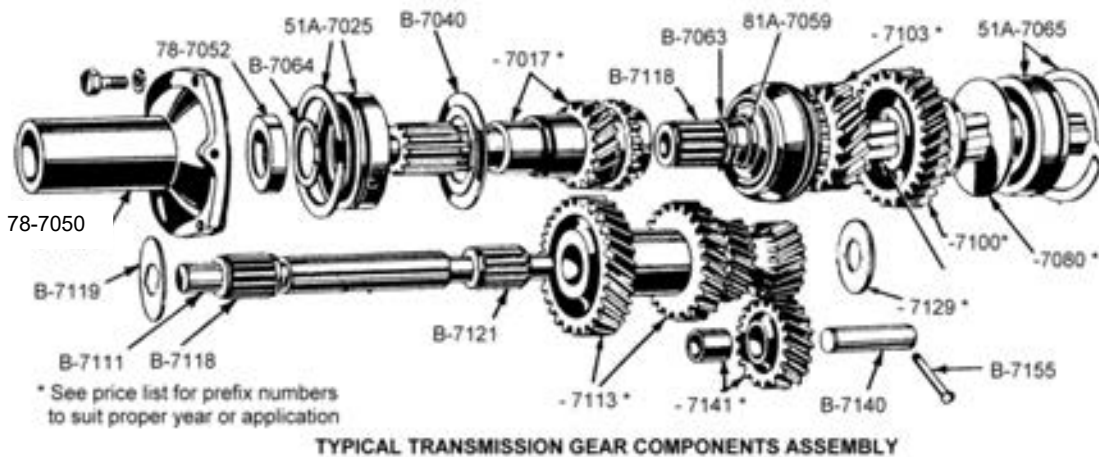

The Ins & Outs of Early Ford Transmissions
 Helpful illustrated manual to aid in the rebuilding of 32-48 car & 32-52 light truck transmissions
Part no. VB12 \$35.00

TRANSMISSION SYNCHRONIZER & PARTS

8M-7124	Complete synchronizer assembly, rebuilt original, includes 3 clips & brass blocking rings	40-48	115.00 ea
81A-7105	Interior hub, 85-95 HP	39-48	ASK
01A-7106	Outer sleeve, 1.25" wide	40-48	ASK
81A-7107	Brass synchronizer blocking rings	38-48	12.00 ea
51A-7109-S	Synchronizer hardware, 3 clips and 2 springs	39-48	10.00 set
81A-7109-S	Synchronizer, ball & spring set.....	40-48	13.00 set
81A-7059	Snap ring.....	38-48	3.50 ea
B-7069	Second gear front thrust washer ..	32-40	5.50 ea
81A-7069-A	Synchronizer hub spacer .0630-.0655" thick x 1.81" OD *....	38-48	5.50 ea
81A-7069-B	Synchronizer hub spacer .0680-.0710" thick x 1.81" OD *....	38-48	5.50 ea
* Note: Not required with 8M-7124 Synchronizer			
81A-7071	Intermediate gear rear washer, 8 slots, 2" OD	38-48	6.25 ea
68-7071	Second gear rear thrust washer...	32-39	6.75 ea

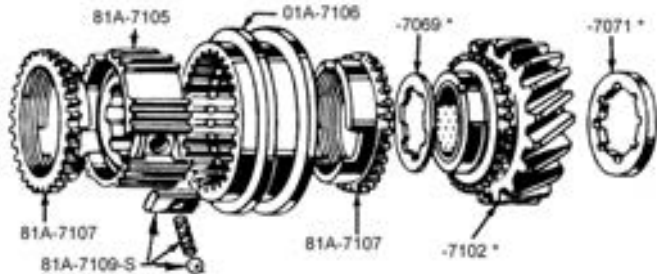

* See price list for prefix number to suit proper year or application



8M-7124



51A-7109-S



81A-7109-S

TRANSMISSION COUNTERSHAFT

B-7111	All 85-95 HP, 8 1/4" long	32-48	13.50 ea
--------	---------------------------------	-------	----------



B-7111

TRANSMISSION BEARINGS

B-7118	Cluster gear bearing, short, 2 required per transmission	32-48	6.00 ea
B-7121	Cluster gear bearing, long	32-48	6.00 ea
51A-7025	Front main drive gear bearing, includes snap ring	32-48	17.50 ea
51A-7065	Rear main shaft bearing, includes snap ring	32-48	17.00 ea

TRANSMISSION MAIN SHAFT PARTS & SEALS

B-7040	Oil baffle for main drive gear.....	32-48	3.00 ea
78-7050	Front bearing retainer, 85-95 HP, also can be added to install 78-7052 seal on 1932-1936 transmissions.....	37-48	42.00 ea
78-7051	Gasket only for above 78-7050 (included in B-7153 below)	37-48	1.75 ea
78-7052	Grease seal, front, 85-95 HP, use with 78-7050	37-48	4.00 ea
21C-7052	Grease seal, rear, pickup (open drive shaft only).....	42-56	5.00 ea
B-7064	Snap ring, main drive gear bearing to shaft.....	32-48	2.50 ea
B-7063	Main shaft spacer	32-48	1.50 ea
B-7080	Main shaft oil baffle.....	32-35	1.75 ea
68-7080	Main shaft oil baffle.....	36-48	2.00 ea

TRANSMISSION & U-JOINT GASKETS / DRAIN PLUG

B-7153	Complete set, fits car & pickup transmission. Both floor & column shift models. Includes universal joint gaskets	32-48	11.75 set
BB-7153	Complete set as above except for 4 speed transmission	32-47	20.00 set



B-7153



For proper lubrication we suggest 600W oil. See page 151 for pricing

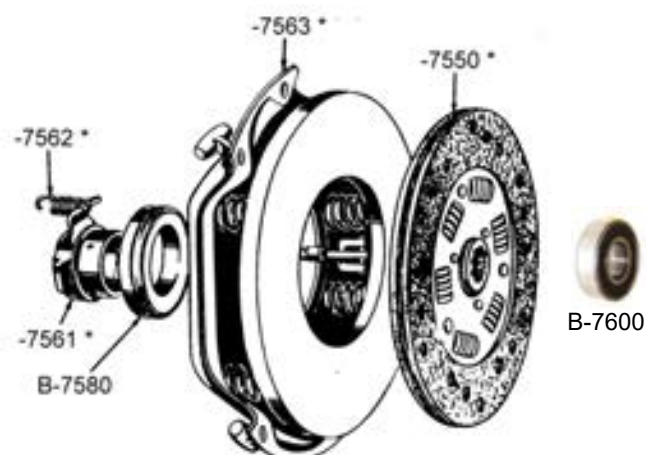

Typical Clutch & Pressure Plate Components

* See price list below for prefix numbers for year & application

CLUTCH THROWOUT BEARINGS, HUBS & RETURN SPRINGS

B-7580	Throwout bearing, 85- 100HP, top quality Timken brand.....	32-48	25.00 ea
48-7561	Throwout bearing hub	35-48	16.00 ea
B-7562	Spring	32-34	1.25 ea
48-7562	Spring, except 60 HP	35-48	1.25 ea

CLUTCH DISCS

91A-7550	9" diameter, cars & pickup	32-40	34.00 ea
81T-7550	11" diameter, 1935-1960 trucks with 4 speed transmission.....	35-60	42.00 ea
74-7550	8.5" diameter, 60 HP	37-39	77.00 ea
29A-7550	10" diameter, cars & pickup	41-48	45.00 ea
A-7550-T	Clutch disc aligning tool	28-48	5.00 ea

Note: No core charge for the above clutch discs.



A-7550-T

CLUTCH PRESSURE PLATES

All pressure plates are sold NEW and require NO core charge or exchange

BB-7563	9" diameter, cars & pickups, no core required, 6 finger style.....	32-34	115.00 ea
09A-7563	9" diameter, cars & pickups, no core required, 3 finger style.....	35-40	110.00 ea
19A-7563	10" diameter, cars & pickup,	41-48	110.00 ea
51-7563	11" diameter, 1935-1964 trucks with 4 speed transmission, NEW, no core required	35-64	125.00 ea
350433-S	Pressure plate mounting bolt kit, Set of 6 bolts with shoulder	32-53	10.00 kit
74-7563	8.5" diameter, 60 HP only, rebuilt, exchange only*	37-39	96.00 ea

CLUTCH PILOT BEARING & BUSHING

B-7600	Clutch pilot ball bearing.....	32-48	5.00 ea
70-7600	Clutch pilot bronze bushing.....	35-48	7.50 ea

CLUTCH PEDAL SHAFTS

B-7506	1932-34 cars & 1932-39 pickup...	32-39	19.00 ea
48-7506	Cars, 6" long.....	35-38	30.00 ea



B-7506

48-7506

01A-7506	5.50" long, cars & 1940-41 pickup..	40-48	12.50 ea
01T-7506	Pickup, 5.42" long.....	42-48	ASK



01A-7506

01T-7506

CLUTCH & BRAKE PEDAL BUSHINGS

B-7526	1932-1934 car & pickup, 1940-1947 pickup	32-47	4.00 ea
48-7526	Car & pickup, 1.80" long	35-38	4.00 ea
01A-7526	Car only .68" long, 1 set required per pedal	40-48	4.00 set
B-7512	Washer "wavy" between pedals...	29-37	1.25 ea



Pedal bushing



B-7512

CLUTCH PEDAL RETRACTING SPRINGS

B-7523	Passenger & pickup 3 3/16".....	1932	10.75 ea
78-7523	Passenger & pickup, 2.81"	33-34	4.00 ea
78-7523	Passenger & pickup, 2.81"	37-38	4.00 ea



B-7523



78-7523

48-7523	Passenger & pickup, 3.44" *	35-36	5.50 ea
91A-7523	Passenger & pickup, 5.40" *	1939	4.00 ea



48-7523



91A-7523

01A-7523	Passenger & pickup, 17.30.....	1940	4.00 ea
----------	--------------------------------	------	---------



01A-7523

11A-7523	Passenger & commercial, 7.30"...	1941	ASK
----------	----------------------------------	------	-----



11A-7523

99A-7523	Passenger & commercial, 7.6" * ..	41-48	4.00 ea
----------	-----------------------------------	-------	---------



99A-7523

*These springs also used for brake pedal.

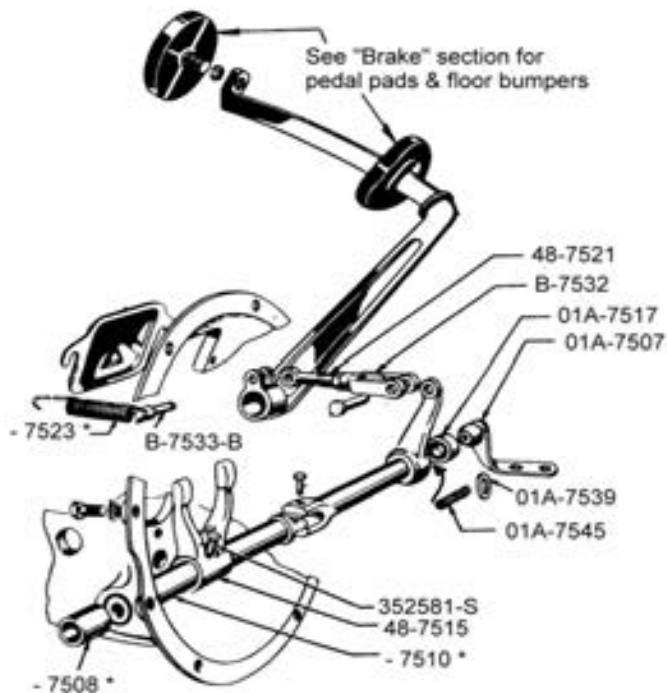

1940-48 Passenger Clutch Pedal & Parts

* See price list below for prefix numbers for year & application

CLUTCH BALL BRACKET PARTS

01A-7507	Passenger & 1940-1941 pickup...	40-48	18.00 ea
01Y-7507	Pickup	42-47	14.00 ea
01A-7517	Ball & bracket bushing, half moon	40-48	5.00 pr
01A-7539	O ring washer.....	40-48	1.00 ea
01A-7545	Equalizer shaft spring	40-48	1.75 ea



CLUTCH PEDAL RELEASE SHAFTS & BUSHINGS

B-7508	Clutch pedal shaft bushing.....	32-34	3.00 ea
40-7508	Clutch pedal shaft bushing, thin wall (Typically used on floor shift trans)	35-48	3.00 ea
51A-7508	Clutch release shaft bushing, thick wall (Typically used on column shift trans) .87" ID x 1.0" OD x 1.25" long.	40-48	7.00 ea
B-7510	Clutch release shaft	32-39	15.00 ea
01A-7510	Clutch release shaft	40-48	38.00 ea

CLUTCH RELEASE FORK & PIN

48-7515	Fork, all 85 & 95 HP.....	32-48	17.00 ea
352581-S	Pin, 1 1/2" long.....	36-48	1.00 ea

CLUTCH ADJUSTING ROD CLEVIS & PIN

48-7521	Clutch pedal adjusting rod 4.75" ..	32-48	10.75 ea
B-7532	Clutch adjusting rod clevis, all styles	32-48	12.00 ea
B-7533-B	Clevis pin for above clevis, grooved head	32-48	3.00 ea



1939 HYDRAULIC BRAKE & CLUTCH PEDAL ASSEMBLY

Use to add hydraulic brakes to 1935-38 cars & pickups. Accepts either original style 3 bolt master cylinder or later 2 bolt Ford unit with dual reservoirs.

91A-2473-K	Pedal assembly	1939	265.00 ea
------------	----------------------	------	-----------



91A-2473-K

1939 CLUTCH RELEASE SHAFT ARM

Shaft & fork available on previous page

91A-7511	Release shaft arm (less shaft).....	1939	20.00 ea
----------	-------------------------------------	------	----------



91A-7511

SPEEDOMETER CABLES & BRACKET

1932-48 Cars & 1932-47 pickups

A-17260-B	Cable with vinyl covered steel casing, 69-1/2" long	30-48	16.00 ea
B-17260-S	Cable with steel casing as original, 71" long	30-48	20.00 ea
A-17260-L	Speedometer cable lube.....	ALL	4.00 ea
99A-17263	Cable bracket, mounts on bottom of cross member, 39-40 car & 39-41 pickup.....	39-41	10.00 ea
01A-17264	Speedometer & Brake cable clip 1940-48 car	40-48	2.50



Speedometer Cable



A-17260-L

01A-17264

99A-17263

SPEEDOMETER GEAR CASE PARTS

B-17275	Gasket for speedometer gear case.....	32-48	.75 ea
A-17286	Snap ring for speedometer gear ..	32-48	1.00 ea
A-17290	Speedometer gear thrust washer.....	32-48	2.00 ea



B-17275



A-17286



A-17290

ORDER & INFORMATION LINE 1-508-278-3980

TOLL FREE 1-800-508-3980

Email: joesantique@charter.net

V-8 WATER PUMPS-NEW

New water pumps have NEW housings, ceramic seals, sealed ball bearings and new helical impellers for improved cooling. *Includes gasket.*

- 68-8502-N NEW. Mounts on cylinder head, RH or LH will work for 1932.32-36 75.00 ea
- 40-8501/2 Pair of RH & LH pumps.....33-34 125.00 pr
- 68-8501/2 Pair of RH & LH pumps.....35-36 ASK



68-8502-N



40-8501/2



68-8501/2

- 78-8501-N NEW, Right hand, cars & pickups...37-48 75.00 ea
- 78-8502-N NEW, Left hand, cars & pickups.....37-48 75.00 ea
- 78-8501-PR Pair of RH & LH pumps, SAVE37-48 125.00 pr
- 78-8501-MT-2 Set of (2) mounting zinc plated bolts with lock washers to install into water outlet, correct 1 1/4" length.....37-48 4.00 set
- 78-8501-MT-8 Set of (8) bolt & washers as above to replace all mounting hardware.....37-48 15.75 set



78-8501-N (RH shown)



78-8501-MT

V-8 WATER PUMPS-NEW-continued

8RT-8501 & 8RT-8502 pumps below were originally used on 1949-53 pickups but later used when installing 8BA engine into 1932-1948 passenger and 1932-1947 pickups.

- 8RT-8501-N Right hand, pickup 49-53 75.00 ea
- 8RT-8502-N Left hand, pickup..... 49-53 75.00 ea
- 8RT-8501-PR Pair of RH & LH pumps, SAVE . 49-53 125.00 pr



8RT-8501-N (RH shown)

V-8 WATER PUMP REBUILD KITS

- 68-8591 V8, 85HP 32-36 30.00 kit
- 78-8591 V8, 85,90 & 100HP..... 3748 30.00 kit
- 52-8591-C V8 60 HP 37-41 50.00 kit



68-8591



78-8591

V-8 WATER PUMP PARTS & GASKETS

- 18-8507 Water pump to block gasket 32-36 2.00 ea
- 78-8507 Water pump to block gasket 37-48 2.00 ea
- 8BA-8507 Water pump to block gasket 49-53 2.00 ea



18-8507



78-8507



8BA-8507

- 18-8509 Water pump pulley, single belt..... 32-36 32.00 ea
- 78-8509 Water pump pulley, single belt..... 37-48 13.00 ea
- 79-8509 Water pump pulley, double belt ... 37-41 13.00 ea
- 68-8520 Water pump shaft bushing, oil lite 32-36 2.50 ea
- 78-8520 Water pump shaft bushing, oil lite 37-48 2.50 ea
- 358010 Water pump grease fitting with cap, brass, 32-34 4 cylinder, 32-36 V-8..... 32-36 3.00 ea



78-8509



68-8520



78-8520



358010

ORDER & INFORMATION LINE 1- 508-278-3980

TOLL FREE 1-800-508-3980

Email: joesantique@charter.net

4 CYLINDER MODEL B WATER PUMP PARTS

B-8507	Water pump gasket.....	32-34	1.50 ea
A-8520-S	Water pump bushing with neoprene seal	28-34	21.00 ea
A-8523-Z	Water pump packing nut, like original	28-34	13.00 ea
A-8524	Water pump lead packing, original style.....	28-34	3.00 kit
A-8523-L	Water pump packing with neoprene seals, use with A-8520-Z, 3 piece	28-34	7.00 kit



B-8507



A-8520-S



A-8523-Z



A-8523-L

FAN BELTS

B-8620-S	4 cylinder, printed "Ford" script	32-34	15.00 ea
40-8620	Fan belt, V-8, NO script	33-36	15.00 ea
40-8620-S	Fan Belt, V-8, with printed "Ford" script	33-36	18.00 ea
78-8620-B	Generator & water pump belt 85 & 95 hp molded "Ford" script..	37-48	24.00 ea
78-8620-C	Belt as above but NO script	42-48	13.00 ea
21A-8577-A	Fan belt, 8 cylinder, 85 & 95 HP, 5/8" wide belt, molded Ford script also 1948-52 pickup (8BA engine) ..	42-48	22.50 ea
7RA-8620	Generator & water pump belt 5/8" wide belt, 1948-52 pickup (8BA engine) NO script	48-52	26.00 ea



PRINTED SCRIPT



MOLDED SCRIPT

1933-36 V8 ENGINE

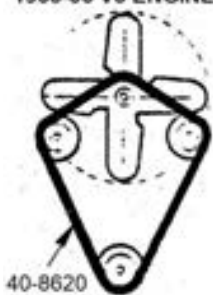

40-8620

1937-41 V8 ENGINE

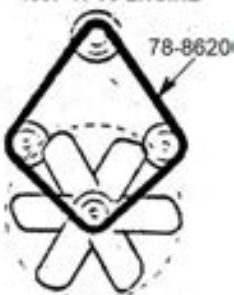

78-8620

1942-48 V8 ENGINE

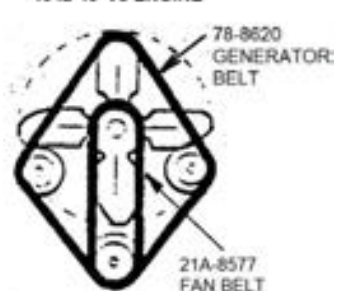

78-8620 GENERATOR BELT

21A-8577 FAN BELT

1949-52 8BA PICKUP ENGINE

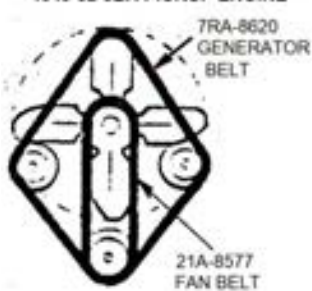

7RA-8620 GENERATOR BELT

21A-8577 FAN BELT

V-8 WATER INLET CONNECTION GASKET

18-8280	Used on 1932 V8's only.....	1932	2.00 ea
40-8280	Used on 1933-1936 V8's only.....	33-36	2.00 ea



40-8280

V-8 THERMOSTATS

11A-8575-A	160 degree, 85 & 95 HP	37-48	9.50 ea
11A-8575-BHT	180 degree, 85 & 95 HP	37-48	9.50 ea
1BA-8575-A	160 degree, 1948-1953 pickup * ..	49-53	7.00 ea
1BA-8575-BHT	180 degree, 1948-1953 pickup * ..	49-53	7.00 ea

* Held in place with 1BA-8592 listed below on 8BA motors only



11A-8575



1BA-8575

WATER OUTLET & GASKET

Used with 8BA motor

8BA-8592	Water outlet, cast steel	49-53	25.00 ea
1BA-8592-A	Water outlet as above except stainless steel for 1 1/4" hose	49-53	25.00 ea
HR-8592-A	Water outlet for 1 7/8" hose, used with 8BA engine in 32-48 chassis.....		20.00 ea
8BA-8255	Gasket (thermostat gasket)	49-53	1.50 ea



1BA-8592



8BA-8255

FAN HUB INTERNAL PARTS 1942-48

Also fits 1942-52 pickup

21A-8626	Spindle bearing USA	42-53	90.00ea
21A-8632	Mounting bracket.....	42-53	13.00 ea
21A-8638	Fan spindle gasket , front	42-53	1.50 ea
21A-8639	Fan impeller & shaft.....	42-52	ASK
21A-8646	Fan spindle gasket, rear	42-53	1.00 ea

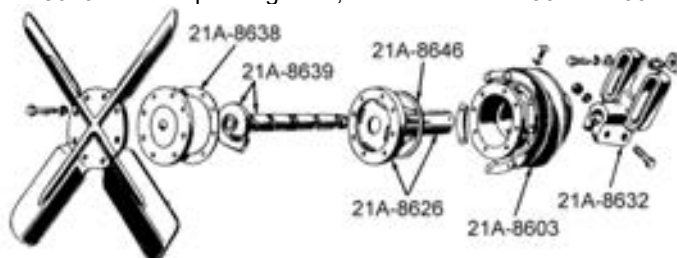

1942-53 8 CYLINDER FAN AND HUB COMPONENTS

FAN HUB ASSEMBLY 1942-48

Also fits 1942-52 pickup

21A-8600-K	Modern updated version by Drake	42-52	165.00 ea
------------	---------------------------------------	-------	-----------



21A-8600-K

UPPER RADIATOR HOSES

- 18-8260 V8, water pump in head, cars & pickups, **(uses B-8287 clamps)** 32-36 8.50 ea
- 46-8260 4 cylinder, cars & pickups, 2" ID x 12" long **NOT AVAILABLE** 32-34



18-8260



46-8260

Note: Above hoses also available in kits in next section.

- 78-8260-S Like original but no metal support, has "Ford" script, 1937-1938 & 1939 standard, cars .. 37-39 24.00 ea
- 78-8260 As above, but no script 37-39 20.00 ea



78-8260 (uses B-8287 clamps)



Detail of script on 78-8260-S

- 91A-8260-S With metal support, "Ford" script, 1939 deluxe cars & 1940-1941 cars & pickups..... 39-41 24.00 ea
- 91A-8260 As above, no script 39-41 20.00 ea



91A-8260 (uses B-8287 clamps)



Detail of script on 91A-8260-S

- 21A-8260-S With metal support, "Ford" script, cars 42-48 20.00 ea
- 21A-8260 As above, no script 42-48 10 ea



21A-8260 (uses B-8287 clamps)



Detail of script on 21A-8260-S

- 91C-8260 Pickups 1 3/4" ID x 2 1/4" long * .. 38-47 4.50 ea
- 91C-8286 Pickups 1 3/4" ID x 3 1/2" long* ... 38-47 5.50 ea

*** Used with radiator pipes & B-8287 clamps**



LOWER RADIATOR HOSES

- B-8286 4 cylinder, 1 3/4" ID x 3 3/4" long 28-34 3.00 ea
- 78-8286 1932-1938, 1939 standard and all 1942-1948, 85 HP only, no script, 1 3/4" x 6" long, V8 32-48 7.50 ea
- 91A-8286-S 1939 deluxe & 1940-1941 all, "Ford" script, V8 39-41 17.50 ea
- 91A-8286 As above, no script, V8 39-41 12.50 ea



78-8286



91A-8286



Detail of script on 91A-8286-S

(Note: These hoses use B-8287 clamps)

RADIATOR HOSE CLAMPS

- B-8261 Use for 2" ID hose (4 Cylinder) 32-34 1.75 ea
- B-8287 Use for 1 3/4" ID hose (V8)..... 32-48 1.75 ea



RADIATOR HOSE & CLAMP SETS-STOCK

- B-8260-K Set of 3 hoses with red line & 6 clamps, 4 cylinder 32-34 35.00 set
- 18-8260-K Set 4 hoses with red line, & 8 clamps, V8, top quality hoses as original 32-36 50.00 set
- 40-8260-S Same as 18-8260-K except with FORD SCRIPT, V8, not original but nice accessory 32-36 60.00 set



18-8260-K



Detail of script on 40-8260-NS

RADIATOR HOSE & CLAMP SETS-CUSTOM

Kits connect later Flathead V8 motor to early stock V8 radiator. All kits include (2) upper hoses, (2) lower hoses & (8) stainless steel Ford script clamps. (Will not fit 4 cylinder stock radiator.)

- HR-8262-AK 1932 V8 Car with 1937-48 V8 & stock fan 60.00 set
- HR-8262-BK 1933-34 V8 Car with 1937-48 V8 60.00 set
- HR-8262-CK 1935-36 V8 Car with 1937-48 V8 60.00 set



HR-8262-BK



HR-8262-CK

HEATER HOSE NIPPLE

- 91A-15160 Installs in lower hose 39-48 21.00 ea



91A-15160

TEMPERATURE SENDING UNITS, GAUGES & PARTS

- 48-10882 Clip (temperature gauge wire and ignition coil wire to spark plug wire conduit) 35-44 1.25 ea
- 8A-10990 Temperature sending bulb, inset into head, double prong, 6 volt 40-48 45.00 ea
- 8A-10884 Temperature sending bulb, single prong, 6 volt 39-48 45.00 ea
- B6C-10884 Temperature sending bulb, single prong as above except 12 volt..... 39-56 50.00 ea



48-10882



8A-10884



8A-10990
B6C-10884

RADIATOR

Dual core-Original design

91A-8005-B 1939 Deluxe, 1940 car,
1940-41 pickup 1940 850.00 ea



RADIATOR CAPS

B-8100 Passenger* 1932 30.00 ea
 B-8100-Q With quail ornament top 1932 55.00 ea
 40-8100-AR Passenger by Drake 1933 50.00 ea
 46-8100-A Pickup* 1933 20.00 ea
 40-8100 Passenger* 1934 20.00 ea
 46-8100-B Pickup* 34-36 20.00 ea

***Note: These caps are by Vintique. Also available by Bob Drake for \$50.00 each.**

48-8100 Car 35-36 50.00 ea
 77-8100 Pickup, use with 78-8100-B 1937 50.00 ea
 78-8100-B Passenger & 1937-1951 pickup,
pressure rated 4 lbs. Nice reproduction
with better sealing to radiator neck 37-51 25.00 ea
 41A-8100-A Pressure cap as above but
replacement type 37-51 8.00 ea
 78-8100 Passenger & 1937-1947 pickup,
non pressure style 37-48 9.75ea
 B-8100-RK Cap repair kit, includes brass
washers & locking cup, 1932-1934
passenger & 1932-1936 pickup,
also use with 1932-1934
greyhound caps listed below 32-36 10.00 kit

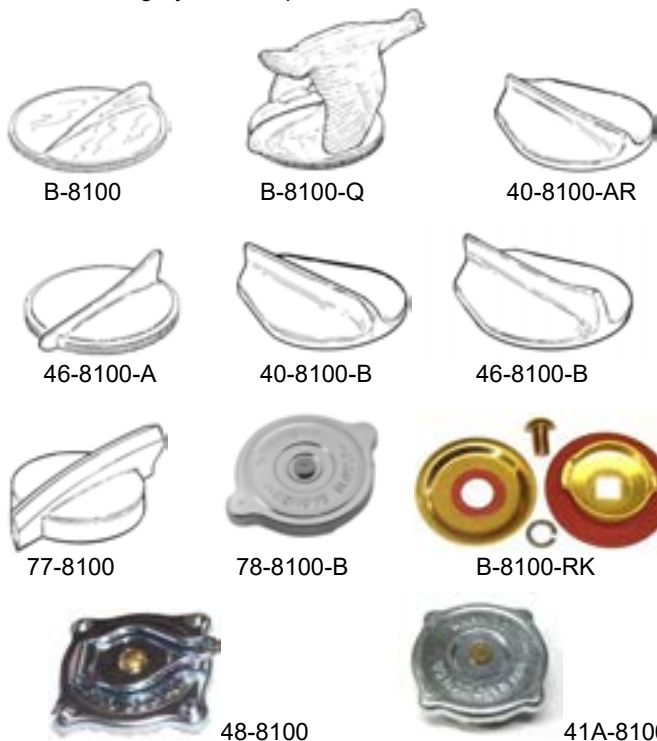

RADIATOR MOUNTING KITS

B-8130-S Radiator pad, bolt & spring kit,
1928-1948 passenger and
1928-1947 commercial 28-48 6.00 kit
 B-8130-SS Radiator mounting kit as above,
stainless steel 28-48 10.00 kit
 B-8125 Radiator to frame pad only 28-48 .75 ea



RADIATOR SUPPORT RODS & BRACKETS

A-8133-SS Support rods, 26" long** 28-31 31.00 pr
 B-8133-SS Support rods, 31-1/2" long** 32-34 31.00 pr
 B-8133-SS-L Support rods, 32-1/2" long** 35-39 35.00 pr
 U-8133-SS support rods, 35" long** 40.00 pr



****Note: Above rods are polished stainless steel with hardware. Can be cut down up to 2" if needed. Measure your old rods prior to ordering.**

B-8140/41-SS Support rod brackets on firewall,
stainless steel, & 1932-34 pickup 1932 12.50 pr
 40-8140/41-SS Support rod brackets on firewall,
stainless steel, & 1939 Standard ... 33-38 22.00 pr
 40-5283/4-2 Bushings (rubber) for radiator
support rods, 1 pair (4 pieces) 35-36 10.00 pr

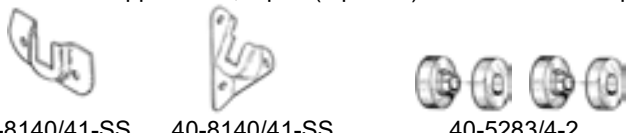

RADIATOR OVERFLOW TANKS

B-8005-W013 13" long, 1 1/4 pint capacity 09-27 52.00 ea
 B-8005-W015 15" long, 1 1/2 pint capacity 28-29 52.00 ea
 B-8005-W017 17" long, 1 3/4 pint capacity 30-34 52.00 ea
 B-8005-W019 19" long, 2 pint capacity 35-48 52.00 ea

Tanks are polished stainless steel with aluminum cap and include mounting hardware. Length measurement is from bottom of tank to top of cap.

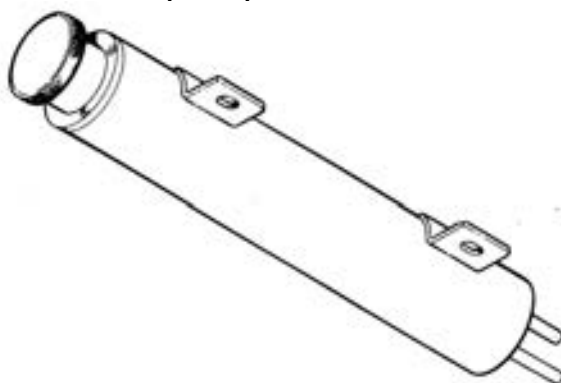

RADIATOR DRAIN COCKS

B-8115 Replacement type, brass 1932 7.00 ea
 48-8115 Offset grip 33-48 19.00 ea
 8A-8115 Wing type grip 40-48 6.00 ea



ORDER & INFORMATION LINE 1- 508-278-3980 TOLL FREE 1-800-508-3980 Email: joesantique@charter.net

GAS TANKS

Die stamped steel and similar to original.

- B-9002 Cars, accepts modern sending unit, stock 10 gallon capacity1932 375.00 ea
- B-9002-LG Cars, as above except 16 gallon capacity1932 375.00 ea



B-9002

- 40-9002-A Cars, except 34 Victoria, includes "no-spill" gas gate at filler * 11 gallon capacity as original.....33-34 300.00 ea



40-9002-A

- 67-9002 Victoria, with cast steel neck* 1934 325.00 ea
 - 67-9002 Pickup, with cast steel neck*33-37 325.00 ea
- Note: 67-9002 tanks have threaded neck & 14 gallon capacity as original.*



67-9002

- 68-9002 Cars, with cast steel neck*35-36 325.00 ea
- Note: 68-9002 tanks have threaded neck & 14 gallon capacity as original.*



68-9002

**Note: Accepts aftermarket 6 hole sending unit 99A-9275 offered on next page to work with original gauge. Original sending units will not fit into these tanks, To use original 5 hole or hydrostatic (1933-1935) units order 40-9003 adaptor below.*

- 40-9003 Hydrostatic tank adaptor kit33-35 45.00 kit



GAS TANKS continued

- 78-9002 Cars, (early 1937)1937 325.00 ea



78-9002

- 81A-9002 38-40 Cars & 38-41 Pickup 38-41 275.00 ea
- 81A-9002-SS 38-40 Cars & 38-41 Pickup, stainless steel construction 38-41 525.00 ea



81A-9002

- 11A-9002 Ford cars, also fits 39-40 Mercury... 41-48 240.00 ea



11A-9002

**Note: Accepts aftermarket 6 hole sending unit 99A-9275 offered in next section to work with original gauge. Original sending units will not fit into these tanks.*

GAS TANK MOUNTING PARTS & MISC

- B-9002-SK Gas tank to frame mounting kit, 8 pieces 32-48 6.50 kit
- B-9002-MBSS Gas tank to frame mounting kit, 8 pieces, stainless steel..... 32-48 12.00 kit
- 21A-9046-K Gas tank mounting bracket kit, 3 brackets & 3 pads, cars 42-48 49.00 kit

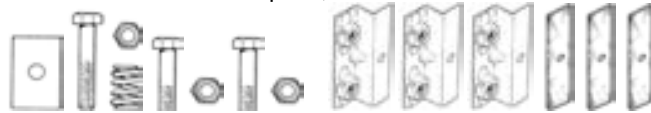

B-9002-SK & B-9002-MBSS

21A-9046-K

- 48-9299 Gas tank to frame pads, rubber ... 35-36 6.00 pr
- 78-9299 Gas tank to frame pads, rubber ... 37-40 6.00 pr



- 40-16396-SK Gas tank cover screws set, car.... 33-34 3.00 set

FUEL SHUT-OFF VALVE

- BB-9189-U Brass, pickups & trucks only..... 28-47 33.00 ea
- A-9189-FS Gas tank filter, fits in above valve 32-47 5.00 ea



BB-9189-U



A-9189-FS

GAS TANK FILLER PIPE & TANK WASHER

- 48-9034 Cars, threaded sleeve 1935 47.50 ea
- 67-9034 Pickup, threaded sleeve 33-36 47.50 ea
- 68-9034 Cars, threaded sleeve A= 9" B=4 1/2" 1936 47.50 ea
- 78-9034-A 1936 to early 1937 cars with threaded sleeve A= 9 3/4" B= 5 3/4" ... 36-37 47.50 ea

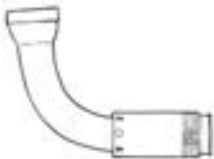

48-9034

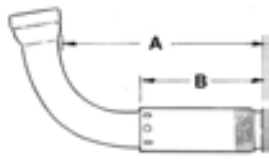

68-9034 & 78-9034-A

- 77-9034-A Pickup, threaded sleeve 1937 47.50 ea
- 46-9051 Tank washer, lead, for above pipes with threaded sleeve, 35-37 pass, 34 Victoria, 33-36 pickup 33-37 9.50 ea
- 78-9034-B Late 1937 cars, clamp on hose 1937 42.50 ea

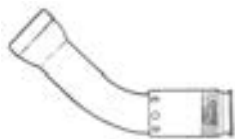

77-9034-A



46-9051



78-9034-B

- 91A-9034-B Cars, clamp on hose 38-40 42.50 ea
- 81C-9034-B Pickups, clamp on hose 38-41 42.50 ea



91A-9034-B



81C-9034-B

- 21A-9034-A Cars, clamp on hose 41-48 47.50 ea
- HR-9047 Flexible for custom applications 12" long with 2" - 2 1/4" inside diameter ... 35.00 ea



21A-9034-A



HR-9047

GAS TANK CONNECTION HOSES & CLAMPS

- 78-9047 Connector hose 1937-1940 passenger, 1937-1941 pickup and 1940-1947 panel truck 37-41 10.00 ea
- 21A-9047 Connector hose 2 1/4" ID 1941-1948 cars (except station wagon) & 1942-1947 pickup 41-51 10.00 ea
- 11A-9047-B Connection hose station wagon ... 41-48 10.00 ea
- B-8261 Hose clamps 37-40 1.75 ea
- 11A-8287 Hose clamps 41-48 2.00 ea



Gas Connection Hose



Hose Clamp

GAS TANK DOOR BUMPERS & HINGE SPRING

- 11A-16378-A Rubber bumpers, passenger 41-48 2.00 pr
- 11A-16377-C Hinge spring, passenger 41-48 7.00 ea



11A-16378



11A-16377-C

GAS TANK SENDING UNITS, FLOAT & GASKETS

- 99A-9275 Sending unit, includes gasket & installation screws. Use with 6 or 12 volt, stainless steel with adjustable arm and float 36-56 35.00 ea
- 68-9275-F Float, brass as original 36-48 9.50 ea
- 68-9275-S Float, solid modern type 36-48 5.00 ea
- B-9276 Gauge to tank gasket 32-35 2.75 ea
- 68-9276 Sending unit to tank gasket 36-56 1.50 ea
- 48-700262 Send unit hole cover in floor, cars 35-36 16.00 ea
- 78-700262 Send unit hole cover in floor, cars 37-41 16.00 ea

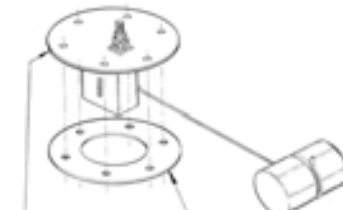

99A-9275



68-9276



68-9275-F



78-700262



48-700262

FUEL LINES & PARTS

- 18-9282 Fuel line, tank to firewall, copper plated steel as original, includes nuts & ferrules, 1/4" x 12' long 32-48 20.00 ea
- B-9243-A Fuel line nut & ferrule set only, use with 1/4" line 32-48 3.00 set
- 18-9296 Clip, fuel line to firewall 32-48 9.50 ea



18-9282



B-9243-A

18-9296

- B-9369 Steel fuel line, copper plated steel with fittings, 4 cylinder 32-34 23.00 ea
- 18-9288 Flexible fuel line, firewall to fuel pump, 9" long, V-8 & 6 cylinder ... 32-48 9.50 ea

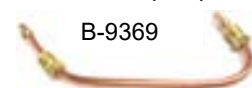

B-9369



18-9288

- 91A-9369-A Fuel line, fuel pump to carburetor, copper plated steel, includes nuts & ferrules, 1/4" dia. x 17" long 32-48 6.75 ea



91A-9369-A

FUEL GAUGE AIR LINE & LIQUID

- 40-9324 Replacement air line kit with red liquid 32-35 29.00 ea
- M-9280 Red fuel gauge liquid only 32-35 ASK



ORDER & INFORMATION LINE 1- 508-278-3980

TOLL FREE 1-800-508-3980

Email: joesantique@charter.net

GAS CAPS

11C-9030-A	Non-locking replacement type, stainless steel, smooth OD	32-48	8.00 ea
18-9030-DC	Non-locking, serrated OD plain face (as original) by Carpenter.....	32-48	16.50 ea
18-9030	Serrated cap as above by Drake..	32-48	28.50 ea
B-9030-V8	Same as 18-9030 except has V-8 by Drake.....	32-48	28.50 ea



18-9030-DC



B-9030-V8

Note: Above caps also fit 1949-1950 pickup

48-18416	Locking cap with "Ford" script, also fits 1949-1950 pickup	32-48	25.00 ea
01A-18416-A	Locking cap, passenger, also fits 1951-1970 pickup	49-56	ASK
01A-18416-B	Locking cap, passenger, also fits 1932-1950 pickup	32-48	42.00 ea



48-18416



01A-18416-A/B

GAS TANK FILLER RUBBER GROMMETS

40-9080	Black	33-34	8.00 ea
40-9080-B	Black, Victoria	1934	25.00 ea
48-9080	Black	35-36	5.00 ea



40-9080



40-9080-B



48-9080

48-9080-B	Black, station wagon	35-37	20.00 ea
68-9080	Black, convertible sedan	1936	23.00 ea
91A-9080	Black, also 1937-1941 pickup	37-40	6.00 ea



48-9080-B



68-9080



91A-9080

78-9080	Black, high neck style	37-40	14.75 ea
21C-9080	Black, pickup	42-47	12.00 ea
7C-9080	Black, pickup	48-52	11.00 ea



78-9080



21C-9080



7C-9080

CHOKE & THROTTLE ROD SETS

B-9700/75-S	Cars & pickups	32-38	14.00 pr
91A-9700	Cars	39-40	60.00 pr
01A-9700	Cars *	1940	50.00 pr

*Can be used for 1940-41 pickups but must be shortened.
Knobs also available, see Dash Knob Sets section.



B-9700/75-S

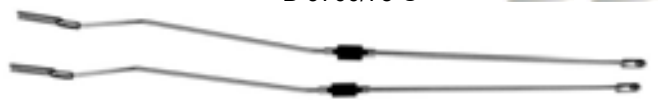

91A-9700



01A-9700

CHOKE & THROTTLE ROD PARTS

B-9702	Connector sleeve joint	32-39	2.00 ea
91A-9702	Rubber rod joint	39-48	5.00 ea
91A-9714-A	Carburetor & accelerator rod rubber insulator	39-48	.75 ea



B-9702



91A-9702



91A-9714-A

UNIVERSAL CHOKE OR THROTTLE CABLES

7C-9700-U	Cable only		10.00 ea
7C-9703	Choke knob, black with red letter "C"		7.00 ea
7C-9778	Throttle knob, black with red letter "T"		7.00 ea
1C-9703-A	Choke knob, black with white letter "C"		7.00 ea
1C-9778-A	Throttle knob, black with white letter "T"		7.00 ea
7C-9700	Choke/throttle knob, black with NO letter ...		7.00 ea



7C-9700-U



7C-9703



7C-9778



1C-9703-A



1A-9778-A



7C-9700

CHOKE & THROTTLE DASH GROMMETS

B-9719	Black, rubber	32-37	1.50 ea
40-9719	Brown, rubber	32-37	1.50 ea
48-9719	Gray, rubber	35-36	1.50 ea
81A-9719	Replacement type	38-48	5.00 pr
91A-9719	Original style, set of (2) grommets & (2) clips. 1939-40 car & 1940-47 pickup	39-47	24.50 set
91A-9718-B	Grommet clip only	39-48	10.00 pr



B-, 40- & 48-9719



40-9719



48-9719

FUEL PUMPS

11A-9350	With steel bowl, V-8, 85 HP, similar to original for 1934-1942...33-48	63.00 ea
59A-9350	With glass bowl, V8.....33-48	63.00 ea
7HA-9350	Glass bowl, 6 cylinder, H motor ...47-51	ASK
7RA-9350-C	Single action pump, 7/16 fitting...49-50	ASK
1BA-9350-A	Single action pump51-53	ASK

Note: Above pumps include mounting gasket

EFP-9350-6	Electric, 6 volt, 4-6 lbs pressure, includes mounting parts, used with mechanical pump32-53	ASK
EFP-9350-12	Electric, as above except 12 V.....32-53	60.00 ea
EFP-9350-LP-6	Electric, 6 volt, 2-4 lbs pressure, includes mounting parts, used without mechanical pump...32-53	60.00 ea
EFP-9350-LP-12	Electric, as above except 12 V .32-53	60.00 ea

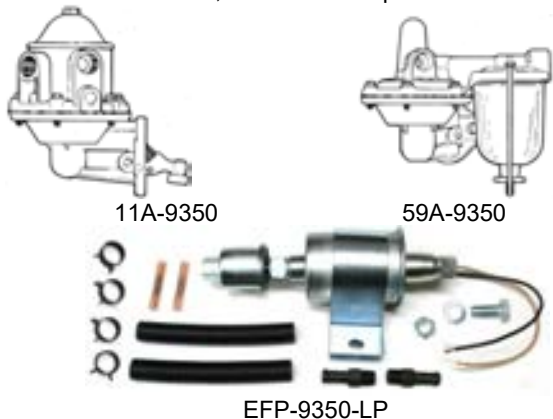

FUEL PUMP REBUILD KITS & PARTS

68-9398	Diaphragm only, V835-48	8.00 ea
11A-9349-RK	Deluxe rebuild kit with diaphragm, gaskets, valves & internal parts ...35-48	22.00 kit



A-9158	Glass sediment bowl, glass only ..28-48	9.00 ea
A-9173	Gasket for glass bowl, cork32-48	.50 ea
A-9155	Brass screen for glass bowl32-48	1.25 ea
A-9156-A	Sediment bowl filter kit for fuel pump with glass bowl33-48	15.00 kit



FUEL PUMP PUSH RODS & ROD BUSHINGS

48-9400-B	Push rod, V-8 with aluminum manifold, 7.87".....32-48	15.00 ea
48-9400-A	Push rod, V-8 with cast iron manifold, 8.87".....32-48	7.50 ea
EAB-9400	Push rod, V-8, 8BA engine49-53	14.00 ea

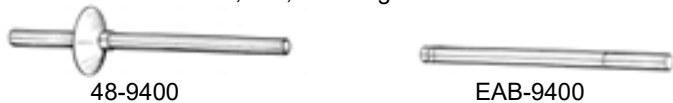

18-6025	Rod bushing, 85 & 95 HP *32-48	5.00 ea
8BA-6025	Rod bushing, 8BA engine *49-53	6.00 ea

***Push rod bushing is located in cylinder block**



FUEL PUMP MOUNTING STAND GASKETS & STUD

B-9374	Fuel pump stand to block gasket, 4 cylinder.....32-34	2.75 ea
40-9374	Fuel pump stand to intake manifold gasket33-48	1.50 ea
40-9417	Fuel pump to stand gasket33-48	1.50 ea
7RA-9417	Fuel pump to stand gasket, 239 ..49-53	1.50 ea
18-6515	Fuel pump mounting stand stud ..32-53	.50 ea



FUEL PUMP BLOCK OFF PLATE

HR-1510	Fuel pump block off plate34-48	20.00 ea
40-9417	Gasket for above33-48	1.00 ea



ACCELERATOR PARTS

A-9765	Accelerator foot rest post with locking nut32-47	5.00 ea
A-9770	Accelerator foot rest base.....32-37	4.00 ea
48-9727	Accelerator pedal rod, pedal to linkage35-48	8.00 ea
48-9735	Accelerator pedal, passenger35-48	14.00 ea
48-700350	Gas pedal rod floor board seal35-40	3.00 ea

48-9735 48-9727

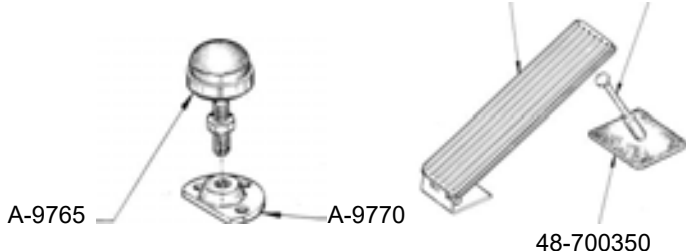

48-9737	Accelerator spring35-48	5.00 ea
99A-9747-B	Accelerator to carburetor rod, 10.44" long28-39	10.00 ea
91A-9747	Accelerator to carburetor rod, 10.75" long39-48	7.75 ea

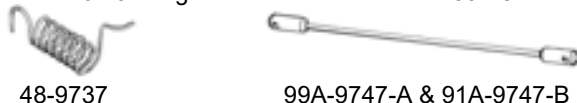

REPLACEMENT CARBURETOR ASSEMBLY

59A-9510-N Carburetor, new, top & body are styled like 49-53 carburetor, FORD script on bowl, includes gasket38-48 ASK



CARBURETOR REBUILD (REPAIR) KITS / PARTS

67-9590 V-8 Stromberg.....33-38 20.00 kit
 67-9590-MAJ Stromberg Kit as above except to include .048" main jet.....33-38 33.00 kit
 67-9533-W Jet wrench for Stromberg jets33-38 32.50 ea
 40-9550 Carburetor float, Stromberg33-38 16.00 ea



67-9590-MAJ



67-9533-W



40-9550

59A-9590 V-8 239 Ford & Holley, neoprene accelerator pump38-53 22.00 kit
 78-9631 Accelerator pump only, leather39-56 11.00 ea
 78-9564 Needle & seat38-56 4.00 set
 78-9550 Carburetor float Ford & Holley38-42 15.00 ea



59A-9590



78-9631



78-9564



78-9550

7HA-9590 6 cylinder Holley,(G & H engines) ...41-51 21.00 kit

CARBURETOR GASKET SETS

B-9502-S 4 cylinder Zenith.....32-34 4.00 kit
 67-9502-S V-8 Stromberg.....33-38 10.00 kit
 21A-9502-S V-8 239 Ford & Holley.....38-53 10.00 kit



67-9502-S



21A-9502-S

CARBURETOR TO MANIFOLD GASKETS & MOUNTING STUD

40-9447-A Carburetor gasket, V8 33-37 2.00 ea
 40-9447-B Carburetor gasket, V8 38-53 2.00 ea
 40-9510-HDW Carburetor mounting stud kit for Stromberg & Ford carburetors , set of (3) 1 1/4" long studs with nuts . 32-48 6.00 kit



40-9447-A



40-9447-B



40-9510-HDW

PHENOLIC CARBURETOR SPACER KITS

Spacers are 1/2" thick with 2 gaskets & 3 studs
 HR-9447-A For Stromberg 3 bolt carburetors. 33-38 25.00 ea
 HR-9447-B For Holley/Ford 3 bolt carburetors 38-51 25.00 ea



HR-9447-A



HR-9447-B

AIR CLEANER ELEMENTS

48-9600-C Copper mesh only 34-36 10.00 ea
 48-9600-CK Copper mesh with outer retainer 34-36 12.00 ea
 78-9600-C Copper mesh only 37-41 12.00 ea
 78-9600-CK Copper mesh with outer retainer..... 37-41 25.00 ea



48-9600-C



48-9600-CK



78-9600-CK

ACCESSORY AIR CLEANERS

HR-9600-SM "Hot Rod" type, chrome plated, fits 2 5/8" carburetors such as 97's. Includes stainless steel clamp and paper element, 8 cylinder with smooth OD 32-53 14.00 ea
 HR-9600-LV Same as above except louvered OD, 32-53 14.00 ea
 HR-9600-E Replacement filter element for HR-9600-SM & HR-9600-LV 32-53 6.00 ea



HR-9600-SM



HR-9600-LV



HR-9600-E

BATTERY TRAY ASSEMBLIES & PARTS

- B-5151 Battery tray assembly 1932 32.00 ea
- 40-5151 Battery tray assembly, cars and pickups.....33-34 29.00 ea

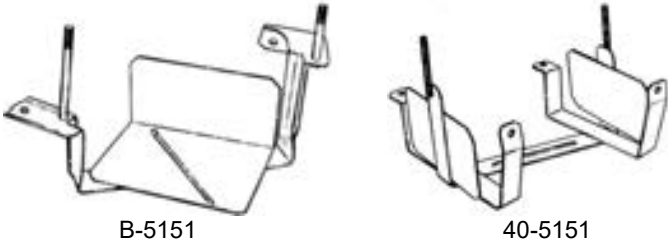

- 68-5153 Battery box lower frame35-36 26.00 ea
- 48-700374 Battery splash guard, rubber.....35-36 5.00 ea



- 78-700740 Battery box assembly, 37-38 all 39 Standard cars, 37-39 pickup ...37-39 120.00 ea

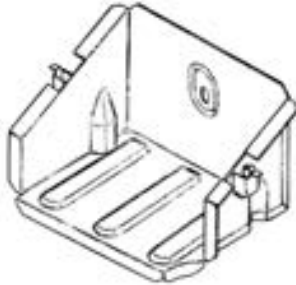

78-700740

- 91A-5154-BK Battery tray & hold down kit, all parts with hardware included, Deluxe cars1939 160.00 kit



91A-5154-BK (Hardware not shown)

- 01A-10732 Battery tray assembly, also 1940-1941 pick-up 1940 50.00 ea
- 11A-10732 Battery tray assembly, car only41-48 85.00 ea
- BATTRAY Battery tray as above except with no mounting legs, car & pickup41-52 40.00 ea
- 7C-10732 Battery tray assembly, pickup48-52 90.00 ea

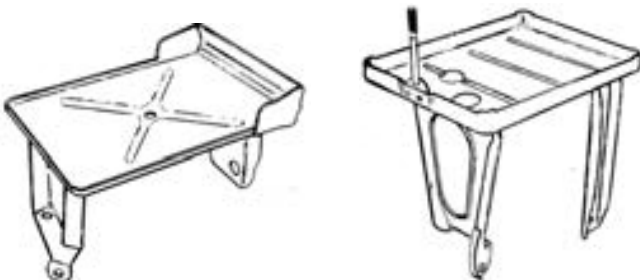

01A-10732

11A-10732

BATTERY HOLD DOWNS & PARTS

- B-5163-S Clamp (corner bracket)..... 1932 4.00 pr
- 01A-5171 Clamp (hold down on dash), 1940 cars & 40-41 pickups 1940 8.00 ea
- 01A-5185-B Hold down pad, 1940 cars and 1940-1947 pickups, used with above 01A-5171 bracket 40-47 1.75 ea

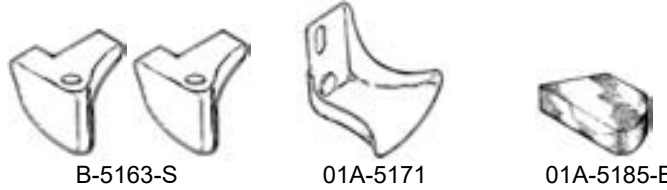

- A-5165 Hold down frame 28-32 10.00 ea
- 51A-5165-A Hold down frame (except 1940 cars & 1940-41 pickups)..... 33-53 14.00 ea
- 78-5165 Hold down frame with cast bracket 1937-38 car, 1939 Standard car & 1937-39 pickup..... 37-39 40.00 ea

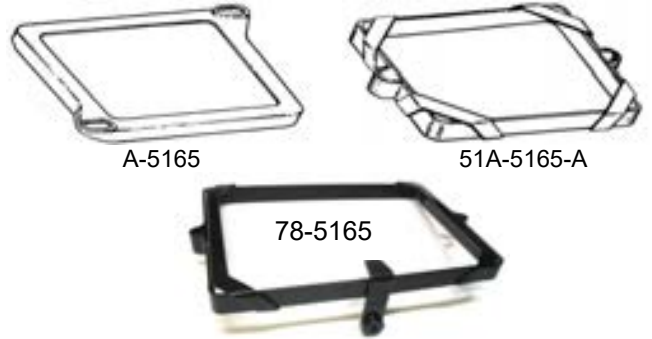

- 11A-5175-E Battery hold down bolt 41-48 3.50 ea
- 11A-5179-S Battery kit nut & washer kit 41-48 3.50 ea

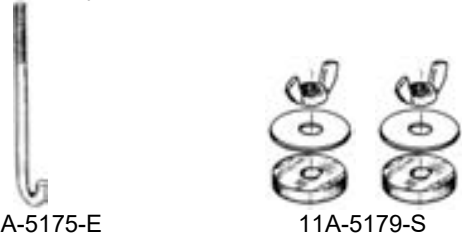

BATTERY COVER

- 48-7000336 Stamped steel..... 35-36 50.00 ea



BATTERY MAT

- BATMAT Absorbs & neutralizes battery acid & vapor, 8" x 12", cut to size as needed 7.75 ea



GENERATOR CUT OUT

Positive ground as original

A-10505-F NO FORD script, foreign made32-39 24.00

VOLTAGE REGULATOR CONVERSION, V8 1932-1939

Looks like original cutout but provides modern convenience of a voltage regulator. Not just a diode but complete conversion to a more efficient voltage regulator. Protects the generator and electrical system from burn out due to overcharging. Adds years of life to generator and battery. Installs easily in minutes without alterations or rewiring.

S10505R-V8 Voltage regulator, positive ground with FORD script, 6 volt32-39 78.00 ea
 S10505R-V812 Voltage regulator, positive ground with FORD script, 12 volt32-39 92.00 ea
 S10505R-V8N12 Voltage regulator, negative ground with FORD script, 12 volt32-39 92.00 ea



A-10505-F (less script) S10505R



51A-10505



91A-10610

VOLTAGE REGULATOR

51A-10505 6 volt, 30 amp, mount on firewall.....39-48 40.00 ea
 91A-10610 Mounting grommet set of 339-48 6.50 set

GENERATOR BRUSH SETS AND SPRING

40-10043 Brush set, 3 brush type32-39 3.50 set
 01A-10043 Brush set, 2 brush type40-48 4.75 set
 91A-10057 Brush spring, 2 brush type39-48 6.50 ea



40-10043



01A-10043



91A-10057

GENERATOR BEARINGS

B-7600 Small roller bearing, 1932-1934 4-cylinder and 1940-1948 V832-48 4.00 ea
 18-10094 Tapered roller bearing only V8.....32-37 19.75 ea
 18-10094-R Tapered roller race only V8.....32-37 9.50 ea
 79-10094 Large roller bearing, 8-cylinder37-41 10.00 ea



B-7600



18-10094



18-10094-R



79-10094

GENERATOR PLATE ASSEMBLY & BUSHING

78-10128 Generator rear end plate bushing37-48 1.25 ea
 40-10129 Generator rear end plate Assembly, NOS.....33-38 25.00 ea



78-10128



40-10129



ALTERNATOR CONVERSIONS FOR V8 FLATHEAD

These kits come complete with mounting bracket and pulley. 1933-39 pulleys accept mounting of fan as original. These 30 amp one wire alternators are easy to install and include installation instructions. Eliminates problems related to original generators and provides easier starting, brighter lighting & extended battery life.

40-10000-A6V 6 volt positive ground 33-39 215.00 kit
 40-10000-A12V 12 volt negative ground 33-39 215.00 kit
 01A-10000-A6V 6 volt positive ground 40-41 160.00 kit
 01A-10000-A12V 12 volt negative ground 40-41 160.00 kit
 21A-10000-A6V 6 volt positive ground 42-48 160.00 kit
 21A-10000-A12V 12 volt negative ground 42-48 160.00 kit



40-10000



01A-10000



21A-10000

STARTERS

18-11002 6 volt, rebuilt LESS DRIVE, \$50 core fee 32-53 145.00 ea
 18-11002-12VN 12 volt, new WITH modern drive, no core fee..... 32-53 165.00 ea



18-11002-12VN



51A-11140

STARTER MOTOR PARTS

18-11052 Front end plate bushing, 3/4" OD, 1/2" long 32-48 1.50 ea
 18-11057 Brush set, 4 pieces 32-48 5.75 set
 18-11083/85 Field coils, RH & LH 32-48 36.00 set
 B-11135 Bushing for rear end plate, .627" ID, .753" OD, 1.155" long ... 32-48 2.00 ea
 51A-11140 Starter to oil pan attaching bracket..... 39-48 6.00 ea

STARTER DRIVE & PARTS (BENDIX)

B-11350-RC Complete starter drive (Bendix), with spring, original style 28-53 40.00 ea
 B-11375 Spring 28-53 10.00 ea
 B-11377 Head screw, 3/8" 28-53 1.00 ea
 B-11379 Lock washer..... 28-53 2.75 ea
 B-11382 Screw, 3/8"..... 28-53 1.25 ea
 B-11350-M Starter drive, modern style, recommended for 12 volt applications 28-53 24.50 ea
 A-11384 Starter drive woodruff key 28-53 .75 ea

B-11382 B-11379 B-11375 B-11377 B-11379



B-11350-RC Starter Drive Assembly



B-11350-M



A-11384

STARTER SOLENOIDS

01A-11450	Steel case, with push button, 6 volt, "Ford" script.....	37-48	25.00 ea
21A-11450	Bakelite, with push button, 6 volt..	37-48	21.00 ea
21A-11450-M	Steel case, with NO push button, 6 volt, "FoMoCo" script. Can be used for 12 conversions.....	37-48	25.00 ea



01A-11450 21A-11450-A



21A-11450

FLOOR STARTER SWITCHES

40-11450	8-cylinder, floor type.....	33-34	ASK
48-11450	8-cylinder, floor type.....	35-36	25.00 ea
A-11470	Starter switch push rod.....	28-34	3.00 ea



40-11450



48-11450



A-11470

STARTER BUTTONS

6A-11500	Chrome.....	37-50	8.00 ea
78-11500-A	Standard, light brown.....	1937	15.00 ea
78-11500-B	Deluxe, yellowish brown.....	1937	15.00 ea
81A-11500	Standard & deluxe, ivory.....	1938	15.00 ea
91A-11500	Light yellow.....	1939	15.00 ea
99A-11500	Mercury, pink.....	1939	15.00 ea
01A-11500-A	Standard, sand.....	1940	15.00 ea
01A-11500-B	Deluxe, maroon.....	1940	15.00 ea
09A-11500	Mercury, dark blue.....	1940	15.00 ea
11A-11500	Tan.....	1941	15.00 ea
21A-11500-A	Maroon.....	1942	15.00 ea
21A-11500-B	Butterscotch.....	1942	15.00 ea
51A-11500-A	Chocolate.....	1946	15.00 ea
51A-11500-B	Blue gray.....	1946	15.00 ea
51A-11500-C	Tan.....	46-48	15.00 ea
21C-11500	Black, pickups.....	41-47	15.00 ea



IGNITION LOCK CYLINDER

48-3686	With keys for steering column, includes 68-3729 lock pin, fits 1935 to early 47 cars & 35-47 pickups ...	35-48	22.00 ea
68-3729	Ignition lock pin only.....	36-48	3.00 ea
8A-11582-A	Ignition cylinder & keys, fits some 47-48 cars, use with 6A-11572 below.	47-48	25.00 ea



48-3686



68-3729



8A-11582-A

IGNITION SWITCH HOUSING 1947-1950

6A-11572-B	Ignition switch housing, no cylinder or keys (see above) early 1947 to all 1948 cars	47-48	60.00 ea
------------	--	-------	----------



ORIGINAL STYLE "HURD" KEY BLANKS

B-3685-A	Ignition switch & door lock	32-38	5.00 ea
B-7006080	Glove box & trunk lock.....	32-38	5.00 ea
91A-3685	Ignition switch & door lock 1939-48 car & 1939-47 pickup....	39-48	5.00 ea
91A-7006080	Glove box & trunk lock.....	39-48	5.00 ea



B-3685-A



B-7006080



91A-3685



91A-7006080

IGNITION SWITCH ON-OFF PLATES

B-11556	On-off plate.....	1932	5.00 ea
40-11556	On-off plate.....	33-34	5.00 ea
48-11556	On-off plate.....	35-36	5.00 ea
78-11556	On-off plate by Drake	1937	11.00 ea
81A-11556	On-off plate.....	38-39	5.00 ea
78-11556	On-off plate, cars, by Drake.....	40-48	10.00 ea
81A-11556	On-off plate, pickups.....	40-47	5.00 ea

All switch plates are aluminum & include 2 rivets



B-11556



40-11556



48-11556



78-11556



81A-11556

IGNITION SWITCH PARTS

B-3704	Ignition switch body	32-37	12.00 ea
B-3709	Ignition switch contact brush.....	32-37	12.00 ea
B-3712	Ignition switch housing	32-37	14.00 ea



B-3704



B-3709



B-3712

81A-3704/9-K	Ignition switch contact set, also 1938-1947 truck.....	38-40	18.50 ea
81A-3704	Ignition switch body only, also 1938-1947 truck.....	38-40	13.00 ea
09A-3704	Ignition switch body, cars	41-48	12.25 ea



81A-3704/9-K



09A-3704

B-3731	Special twist off screw	32-48	3.50 ea
40-3735	Ignition switch lever	33-34	17.25 ea
B-3740-SET	Steering and ignition lock ball screw, 7/16" long with lock washer, ball & spring.....	32-40	20.00 kit



68-3729



B-3731



40-3735



B-3740-SET

DISTRIBUTOR CAPS – 8 CYLINDER

18-12106	Outer cap, black.....	32-41	10.00 ea
01A-12106	Outer cap, brown	32-41	12.00 ea
18-12116	Inner terminal.....	32-36	23.00 ea
68-12116	Inner terminal.....	36-41	19.00 ea
21A-12106	Flat crab type cap	42-46	24.00 ea
18-12108	Terminal cap gasket.....	32-41	1.25 ea
18-12115	Distributor terminal cap O-ring	32-41	.75 ea

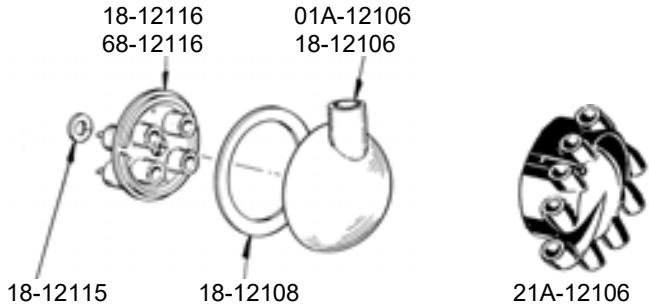

59A-12105	Outer cap	46-48	20.00 ea
59A-12106	Inner terminal.....	46-48	30.00 ea
FAB-12106	Outer cap, copper inserts.....	49-56	9.50 ea



CONTACT POINT SETS – 8 CYLINDER

18-12107	Long arm, 2 screws, NORS	32-36	35.00 set
78-12171-S	2 arms, 2 plates V8 (Can also be used with 6 cylinder).....	36-48	25.00 set
7RA-12171-TQ	Single points.....	49-53	12.00 ea



DISTRIBUTOR ROTORS – 8 CYLINDER

48-12201	Use with 18-12116 inner cap	32-36	28.00 ea
68-12201	Use with 68-12116 inner cap	36-41	20.00 ea
21A-12200	Use with 21A-12106 cap	42-46	8.00 ea
FAA-12200	Use with 59A- & FAB-12106 cap	46-56	4.00 ea

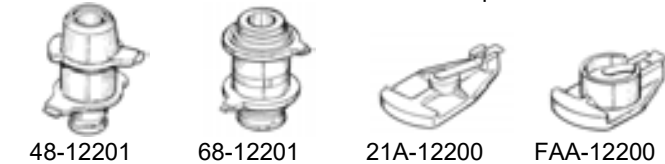

DISTRIBUTOR CAP BOOTS – 8 CYLINDER

18-12113	Cap boot	32-41	6.00 pr
A9AZ-12113	Nipple seal, use with crab type cap..	41-48	.75 ea
59A-12113-S	Cap boot	46-48	10.75 pr



CONDENSOR & PARTS– 8 CYLINDER

18-12300-B	Use with 18-12024 coil.....	32-36	ASK
78-12300	Use with 78-12024 coil.....	36-41	12.00 ea
81A-12300	Use with 81A-12024 coil	38-41	12.00 ea
1GA-12300	Use with 1GA-12024 coil.....	41-48	10.00 ea
7RA-12300-TQ	Correct for 49-56 but can be used 1942-1948 distributor, to replace 1GA-12300 6 or 12 volt coil.....	49-56	10.00 ea
1GA-12312	Rubber boot for 1GA-12300.....	41-48	3.00 ea

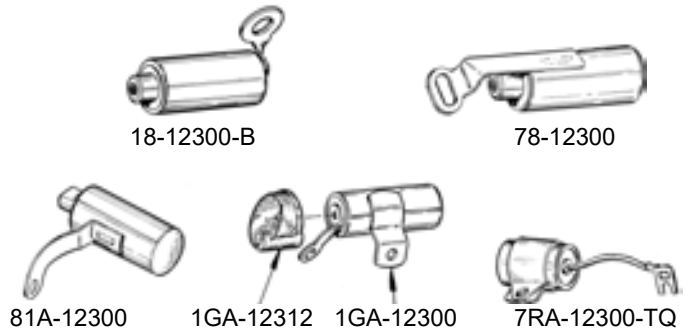

DISTRIBUTOR GASKETS

18-12104-S	Complete set, 8-cylinder.....	32-41	6.00 set
21A-12104-S	Complete set, 6 & 8 cylinder.....	42-48	8.50 set

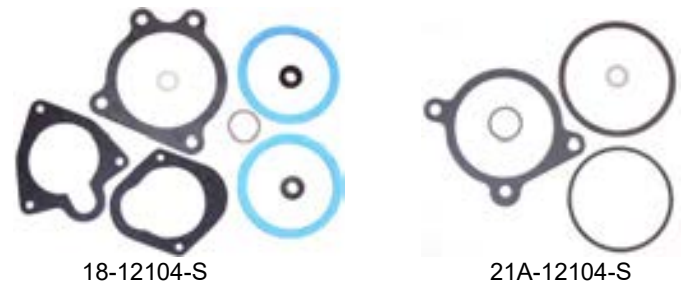

Note: Gaskets listed below are included in above sets.

18-12108	Terminal cap gasket	32-41	1.25 ea
18-12115	Distributor terminal cap O-ring.....	32-41	.75 ea
18-12140	Coil gasket (3 bolt).....	32-36	3.00 ea
78-12140	Coil gasket (2 bolt).....	37-41	1.00 ea
68-12143	Distributor base gasket.....	32-41	2.00 ea
1GA-12143	Distributor base gasket, V8 & 6 cyl	41-48	2.00 ea

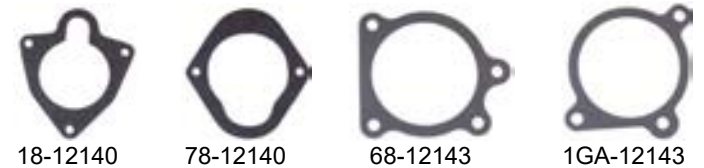

DISTRIBUTOR PARTS – 8 CYLINDER

40-12120	Housing bushing, upper (outer) ...	33-41	4.00 ea
1GA-12120	Breaker plate bushing.....	41-47	ASK
18-12132	Housing bushing, lower, (inner) ...	32-48	5.00 ea
1GA-12134	Distributor housing vacuum seal..	42-48	4.00 ea
18-12138	Rubber plugs	32-40	2.50 pr



DISTRIBUTOR PARTS – 8 CYLINDER

18-12144	Cap bail, 2 required.....	32-41	ASK
21A-12144-S	Cap clip set, 1942-1948 (crab cap), with rivets.....	42-48	6.00 set
59A-12144	Cap bail.....	46-48	3.00 set
59A-12109	Cap clip.....	46-48	6.00 pr

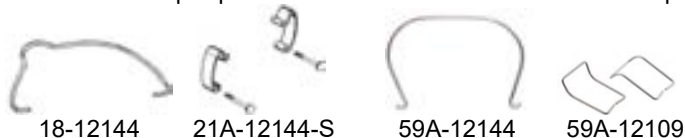

68-12151	Plate, less points , use on 68, 78 & 11A distributors.....	36-41	ASK
21A-12151	Plate, less points.....	42-48	16.00 ea
11A-12175	Shaft.....	37-41	19.00 ea
59A-12182-A	Timing tag, bolt & lock washer....	42-48	6.00 set
18-12220	Vacuum brake plunger with leather end. Includes 18-12225 spring.....	32-48	11.00 ea
18-12225	Vacuum brake plunger spring only.....	32-48	.75 ea
40-12226-B	Vacuum line with fittings.....	34-41	14.50 ea
21A-12226	Vacuum tube lines, with end.....	42-48	ASK
40-12227	Vacuum brake adjuster.....	32-48	ASK
11A-6280	Distributor to camshaft adapter, (extension that fits onto early camshaft to use with 1942-1948 distributor).....	32-41	14.50 ea
7RA-12370-B	Distributor vacuum advance.....	49-53	25.00 ea

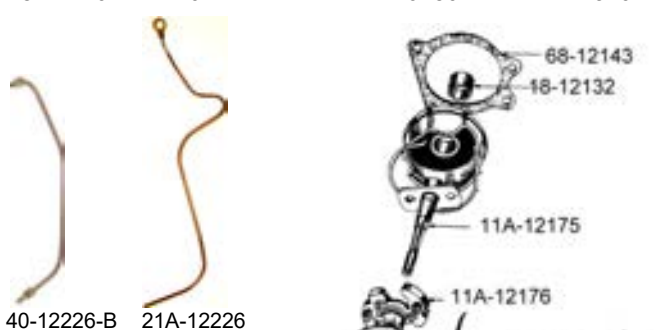

1936-1941 V8 Distributor

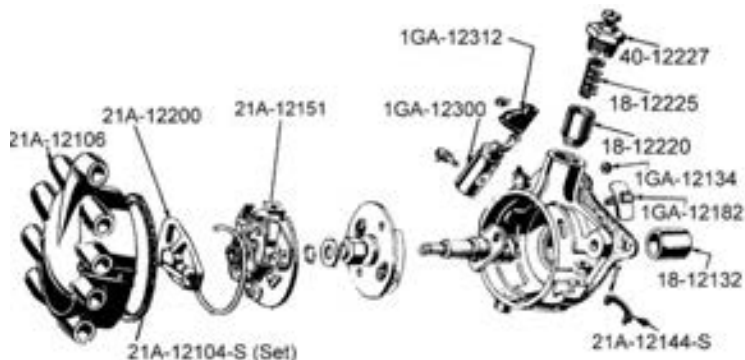

1942-44 V8 Distributor

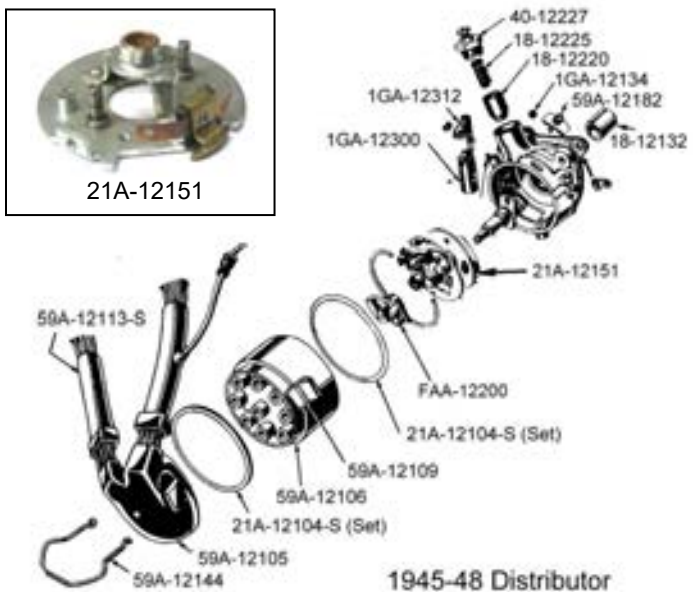

1945-48 Distributor

DISTRIBUTOR PARTS – 4 CYLINDER

A-12105	Distributor body.....	28-34	27.00 ea
A-12115	Distributor cap.....	28-34	6.00 ea
A-12127	Distributor screw & lock nut.....	28-34	2.50 set
A-12132	Distributor shaft bushings, pair....	28-34	2.50 pr
A-12135	Distributor oiler.....	28-34	4.50 ea
A-12144	Distributor cap clip set & rivets....	28-34	5.50 set
B-12195-S	Shaft sleeve and pin.....	28-34	4.00 set
B-12199	Ignition point set.....	32-34	20.00 set
B-12200	Distributor rotor.....	28-34	6.00 ea
A-12210	Distributor cam, made in USA.....	28-34	13.50 ea
A-12213	Cam wrench.....	28-34	2.25 ea
B-12211/13	Cam screw & washers.....	28-34	2.50 set
B-12275	Spark plug connectors (brass), offset, set of 4.....	28-34	7.50 set
A-12280	Distributor heat shield.....	28-34	5.00 ea
B-12300	Condenser.....	32-34	13.50 ea

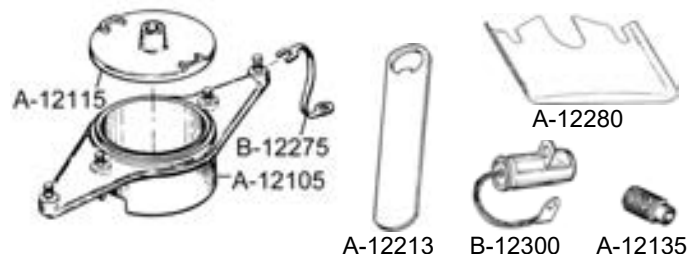

IGNITION COILS & PARTS

B-12000-6V-4	6 volt round coil, 4 cylinder, has Internal resistor.....	28-34	20.00 ea
B-12000-6V-V8	6 volt round coil, use with V8, has Internal resistor *	32-48	40.00 ea
B-12000-12V	12 volt round coil, V8, need ballast resistor SR-12250 *	32-48	40.00 ea
B-12000-CB	Coil bracket for above coils	28-48	5.00 ea

***Note: These used with coil adaptor kits 18-12036-S & 78-12036-S offered below**



B-12000



B-12000-CB

18-12024-RB	Coil, 6 volt, dome type, 3 screw REBUILT, \$50 core fee	32-36	120.00 ea
78-12024-RB	Coil, 6 volt, black case, REBUILT, \$50 core fee	37-41	120.00 ea
78-12024-BRRB	Coil, 6 volt, brown case, REBUILT, \$50 core fee	37-41	120.00 ea
1GA-12024-RB	6volt coil, V8 & 6, REBUILT \$50 core fee	42-48	120.00 ea
18-12010-S	Coil brush and spring set.....	32-36	4.00 set
68-12010-S	Coil brush and spring set.....	37-41	4.00 set



18-12024



78-12024



1GA-12024



68-12010

COIL ADAPTOR KIT

This kit eliminates the coil on the distributor and allows use of B-12000-6V-V8 or B-12000-12V coil listed above which is mounted on top of motor. Coil purchased separately.

18-12036-S	Kit for 3 bolt coil to distributor.....	32-36	42.50 kit
78-12036-S	Kit for 2 bolt coil to distributor.....	37-41	42.50 kit
12036-W	Replacement wire only for above kits		6.00 ea



18-12036-S



78-12036-S

ELECTRONIC VOLTAGE REDUCER

Converts 6 volt gauges to 12 volt.

SR-10606	1 amp, typically used for fuel, water temp & oil pressure gauges, one per gauge, includes instructions		15.00 ea
D-10800	Reduces voltage for all 3 gauges (fuel, temp & oil pressure).....		35.00 ea
V-12874	Reduces 12 volt to 6 volt, 6 amp for higher amperage loads		ASK



SR-10606



D-10800



V-12874

SPARK PLUG WIRE SETS

18-12259-RG	Black, with brass ring end	32-36	49.00 set
78-12259	Color coded, 8 pieces	37-41	51.00 set
21A-12259	Color coded, includes 21A-12298 coil wire, 9 pieces ..	42-44	59.25 set
59A-12259	Brown, V8, 1946-1948 all and 1946-1947 pickup	46-48	56.75 set
5GA-12259	Brown, 7 pieces, 6 cyl, G motor..	46-47	56.75 set
7HA-12259	Brown, 7 pieces, 6 cyl, H motor..	47-51	51.25 set
8BA-12259	Black, 1949-1950 passenger and 1948-1950 pickup	48-50	56.75 set
1A-12259W	Black, molded plug ends, all	51-53	80.00 set
21A-12298	Ignition coil to distributor high tension wire only, 11" long	42-44	6.50 ea



18-12259-RG



21A-12259

SPARK PLUGS

18-12405-C	Champion, 4-cylinder	28-34	8.25 ea
18-12405-M	Motorcraft, 4-cylinder	28-34	4.00 ea
40-12405-C	Champion, 18mm.....	33-37	3.50 ea
40-12405-M	Motorcraft, 18mm.....	33-37	4.00 ea
7RA-12405-C	Champion, 14mm.....	38-54	3.00 ea
7RA-12405-M	Motorcraft, 14mm.....	38-54	2.75 ea



Note: Motorcraft brand spark plugs run a little hotter and many prefer for the daily driver. Plug gap 0.025-0.028"

IGNITION RESISTORS

18-12250	Ignition coil resistor, modern replacement type for 6 volt	32-48	6.00 ea
18-12250-TQ	Ignition coil resistor as above except resistor wound on ceramic core Top quality	32-48	17.00 ea
40-12250-A	Fuse block & resistor, 6 volt.....	33-39	30.00 ea
SR-12250	Ignition coil resistor, for 12 volt conversions, ceramic		16.00 ea



18-12250



40-12250-A



SR-12250

FUSE & TERMINAL BLOCK ASSEMBLIES

A-11450-SF	Accessory safety fuse, bolts to top of starter.	28-34	12.00 ea
B-12251-FP	Fuse block, replacement type, holds 4 fuses with brass screw contacts		15.00 ea
B-12252	Terminal block, 10 gangs of heavy duty brass nickel plated terminals and molded bakelite insulator		13.50 ea



A-11450-SF



B-12251-FP



B-12252

GRILLE & RADIATOR MISC. PARTS

91A-8005-WB	Headlight wire crossover channel	39-40	35.00 ea
91A-8046	Radiator to fender bracket, 39-40 passenger & commercial ...	39-41	32.00 pr
91A-8046-SS	Radiator to fender bracket as above except stainless steel	39-41	40.00 pr
51A-8327	Upper radiator panel, black enamel finish	46-48	79.00 ea
51A-8327-C	Upper radiator panel as above, but chrome plated	46-48	95.00 ea
21A-8327-K	Upper radiator panel shroud seal	42-48	6.00 ea
21A-8208-K	Lower radiator shroud seal.....	42-48	6.00 ea



91A-8005-WB



91A-8046

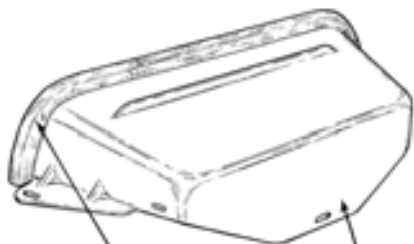

21A-8327-K

51A-8327

01A-8327-B Air deflector, polished stainless steel, to help cooling, deluxe only, accessory by Bob Drake..... 1940 130.00 ea



01A-8327 Air deflector, stainless steel, same as above except fits 1939 deluxe, 1940 standard, 1940-1941 pickup and 1941 sedan delivery..... 39-41 130.00 ea



GRILLE & RADIATOR MISC. PARTS continued

01A-8145-A	Upper grille support, holds grille assembly, 1940 standard and 1940-1941 pickup*	1940	125.00 ea
01A-8145-B	Upper grille support, as above, 1940 deluxe only*	1940	125.00 ea

***These grilles are by Bob Drake and are painted black**

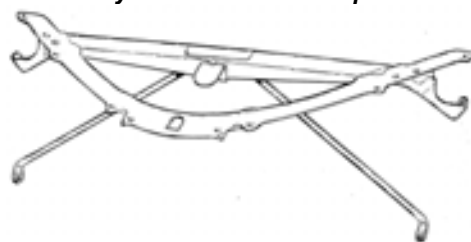

01A-8145-A

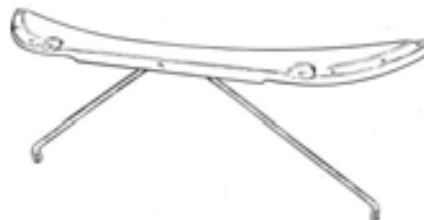

01A-8145-B

91A-8104/5	Fender to grille outer plates, 1939-1940 passenger and 1940-1941 pickup	39-41	50.00 pr
01A-8209	Center grille plate, deluxe, stamped steel	1940	55.00 ea
01A-8434	Lower grille plate, die stamped, deluxe	1940	30.00 ea



91A-8104/5-S



01A-8209



01A-8434

78-8209	Center grille plate, stamped steel	1937	85.00 ea
78-8242/3	Grille mount panel, mounts grille to radiator & hood side, pair.....	1937	60.00 pr
78-8232-B	Front fender support tie	1937	29.00 ea



78-8242/3



78-8232-B

RADIATOR GRILLE PANS

91A-8240-B 1939 deluxe, 1940 standard and deluxe & 1940-1941 pickup, fits under radiator.....39-41 115.00 ea

01A-8188-A Lower grille pan, 1940 standard and 1940-1941 pickup, painted black.....40-41 100.00 ea

01A-8211 Lower grille pan, deluxe, painted black 1940 60.00 ea

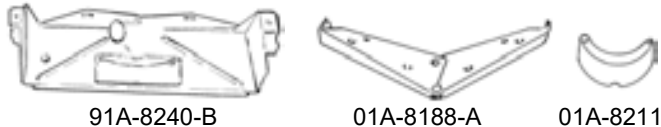

40-8240 Grille pan, fits inside grille and bolts to fenders. Stock with crank hole33-34 95.00 ea

40-8240-S As above but smooth with no crank hole33-34 60.00 ea

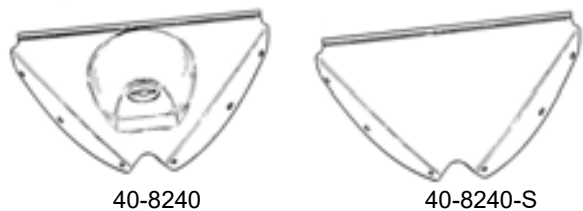

48-8240 Grille pan, car.....1935 125.00 ea

50-8240 Grille pan, pickup1935 125.00 ea



RADIATOR SPLASH SHIELDS & MOUNTING KIT

B-16527 Splash shield, steel, die stamped, Top quality..... 1932 75.00 ea

B-16527-CHOP Splash shield, steel, die stamped, chopped 2"..... 1932 75.00 ea

A-16529-B Felt pad with rivets, front splash shield to grille shell1932 1.00 kit

18-17766/67-S Complete mounting kit, original style for above splash shields... 1932 20.00 kit

B-80017 Screw, nut and lock washer kit only for above splash shields ... 1932 2.50 kit

40-16550 Radiator lower tank splash shield, unpainted steel.....33-34 55.00 ea

68-16554 Radiator shell to cross member shield assembly, unpainted steel..... 1936 70.00 ea

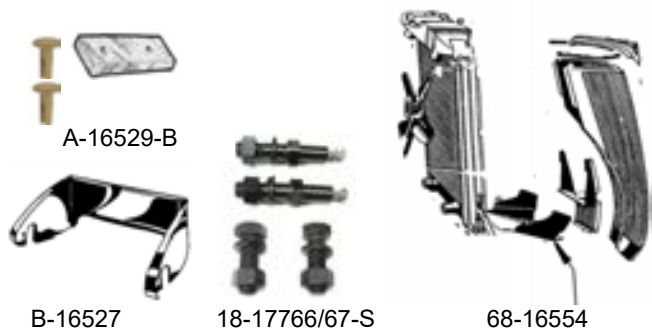

RADIATOR SHELL, INSERT & TRIM-1932

B-8200-OGS Radiator shell, steel, passenger, original style..... 1932 275.00 ea

B-8200-HRS Radiator shell, steel, passenger, street rod type with filled neck 1932 250.00 ea

B-8200-OS Grille insert, all polished stainless steel, with crank hole 1932 275.00 ea

B-8200-SR Grille insert, all polished stainless steel, without crank hole .. 1932 275.00 ea

18-8234 Radiator shell trim..... 1932 50.00 ea

B-8211 Grille crank hole bezel, polished stainless steel..... 1932 16.00 ea

B-8151-A Grille bars, plain steel *..... 1932 4.00 ea

B-8151-SS Grille bars as above except stainless steel *.....1932 5.00 ea

***Note: 43 grille bars required per grille insert.**



B-8200-OGS

B-8200-HRS

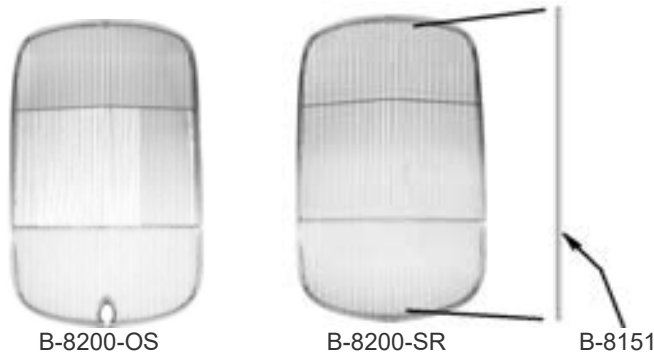

B-8200-OS

B-8200-SR

B-8151

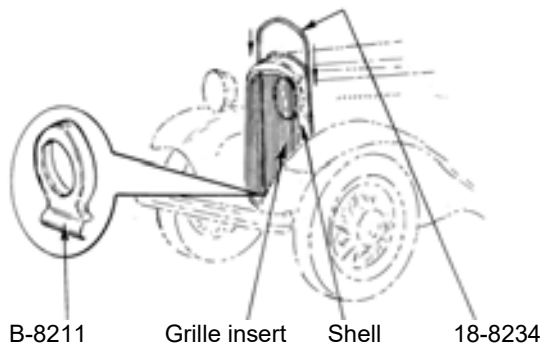

B-8211

Grille insert

Shell

18-8234

RADIATOR SHELL MOUNTING HARDWARE

A-8200-MK Radiator shell fastening kit, 1932 passenger & 1932-1934 pickup, 12 piece, zinc plated, no brackets 32-34 1.50 set

46-8094/6-B Radiator shell mounting kit, with brackets, pickup only 33-34 32.00 kit

GRILLE ASSEMBLIES

1934 Car

Grilles are available either chrome plated or plain steel and include trim with original style 'D' nuts on lower flange.

40-8200 Chrome by Bob Drake 1934 N/A



40-8200

1940 Standard & 1940-1941 pickup

01A-8206/7-AK 2 side pieces, ready to paint, center piece chromed, 1940 standard, 1940-1941 pickup ... 40-41 ASK

01A-8206/7-ACK Chrome sides & center, 1940 standard, 1940-1941 pickup ... 40-41 ASK

1940 Deluxe

01A-8206/7-DC Chrome plated, 2 grille sides and 2 piece center strip, crank hole and cover 1940 ASK



01A-8206/7-AK



01A-8206/7-ACK



01A-8206/7-DC

GRILLE TRIM & MISC. PARTS

1933-1934 Passenger

40-8234 Border trim, includes 40-8234-C coupler clip & mounting clips, stainless steel 1934 85.00 ea

40-8234-C Grille trim coupler clip only, stainless steel 1934 14.00 ea

40-16088-B Front fender tie bracket, painted black 33-34 18.00 ea

40-16088-SS Tie bracket as above except polished stainless steel 33-34 45.00 ea

40-8216-A Crank hole cover, chrome 1933 25.00 ea

40-8216-B Crank hole cover, chrome 1934 25.00 ea

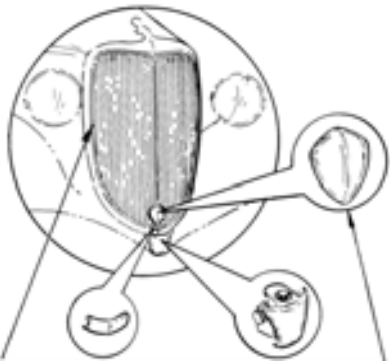

40-8234 (Grille trim) 40-8234-C 40-16088 40-8216

GRILLE SHELL TRIM

1934, 1935 & 1936 Pickup

46-8234 Grille trim, stainless steel with mounting hardware, pickup 1934 100.00 ea

50-8234 Grille trim, stainless steel with mounting hardware, pickup 35-36 ASK

46-8234-HK Mounting hardware kit only for above trim, pickup 34-36 12.00 kit

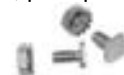

46-8234-HK

GRILLE TRIM & MOLDINGS

1935, 1936 & 1937 Passenger

48-8234 Grille trim, stainless steel, 6 pcs. including outside & centers, plus clips & mounting hardware 1935 130.00 ea

68-8184/5 Outer side grille trim moldings, stainless steel, no mounting clips ... 1936 75.00 pr

68-8157 Center grille trim molding, stainless steel, with mounting clips 1936 50.00 set

78-8200-GTS Grille trim set, stainless steel, 6 pieces, including center trim, outer & top trim and top corner caps, no mounting clips 1937 145.00 set

78-8157 Center grille trim molding only, stainless steel, with mounting clips . 1937 50.00 set

78-8268/9-S Grille trim top corner caps only 1937 25.00 pr



1935



1936



1937

GRILLE TRIM MOLDINGS

1937 Pickup & Commercial

77-8157 Grille center strip 1937 140.00 ea

77-8184/5 Grille outer trim 1937 225.00 ea

GRILLE TRIM & MOLDINGS

1938 & 1939

81A-16852 Front hood ornament, Deluxe* 1938 170.00 ea

81A-8157-B Center grille molding, Deluxe 1938 375.00 ea

91A-8157-A Center grille molding, chrome, Standard 1939 360.00 ea

91A-8168-B Center grille molding, chrome, Deluxe 1939 125.00 ea

91A-8332-K Grill trim kit with mounting hardware, without center molding 91A-8168-B, Deluxe 1939 350.00

**Note: Emblem (48-8212) not included and sold separately.*



81A-16852

91A-8157

81A-8157-B

91A-8168-B

91A-8332-K

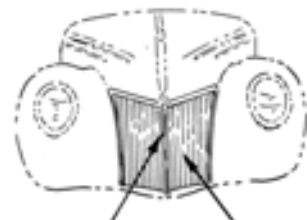

GRILL TRIM & MOLDINGS

1940 Deluxe

- 01A-8418/22 Grille center strip, chrome with stainless crank hole cover and mounting hardware
By Vintique..... 1940 40.00 ea
By Bob Drake..... 1940 100.00 ea
- 01A-8418/22-SR Grille center strip, no crank hole, chrome, 1 piece & mounting hardware
By Vintique..... 1940 50.00 ea
By Bob Drake..... 1940 85.00 ea
- 01A-16856-K Grille moldings, 4-piece set, 40 deluxe 1940 80.00 set
- 01A-8182 Grille to fender bead, stainless steel, deluxe..... 1940 18.00 pr

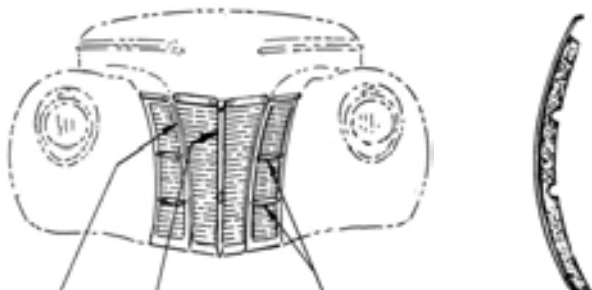

01A-8182 01A-8418/22 01A-16856-K 01A-8182

GRILLE BAR SET

- 1942-1947 Pickup. Die stamped steel. Imported, fair quality**
- 21C-8200-P 15 pieces, plain steel42-47 275.00 set
 - 21C-8200-SET 15 pieces, chrome plated.....42-47 460.00 set

GRILLE MOLDING & TRIM BARS

1946-1948 Passenger

- 51A-8170/1-K Grille moldings, upper, contains center grille emblem, 3 pieces* 1946 280.00 set
- 6A-8170/1-K Grille moldings, upper, contains center grille emblem, 3 pieces*47-48 280.00 set
- 51A-8332-S Trim bars, has correct groove in center, polished stainless steel, unpainted, 3 pieces** 1946 150.00 set
- 6A-8332-S Trim bars, smooth style, polished stainless steel, 3 pieces47-48 ASK

***These grille moldings are painted original colors & include 51A-8170-HK mounting hardware.**

****51A-8332-S was also in early 1947**



51A-8170/1



6A-8170/1



6A-8332-S

51A-8170/1 & 6A-8170/1 51A-8332 & 6A-8332

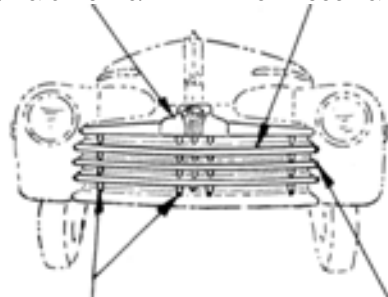

51A-8453 51A-8427

BUMPERS & PADS FOR GRILLE MOLDINGS AND TRIM BARS

- 51A-8427-B Rubber bumper, grille louver at fender, 12 pieces 46-48 5.00 kit
- 51A-8453-S Radiator grille pads, U-shaped, set of 4 46-48 6.00 set

GRILLE PARTS MOUNTING HARDWARE

- 01A-8206-AHK Grille side hardware kit, 1940 standard, mounts grille RH and LH side to fender, lower pan and upper brace, 62 pieces 40-41 10.00 kit
- 01A-8206-DHK Grille hardware kit, deluxe, mounts grille RH and LH sides to vent panel & chin pan, 30 pieces 1940 7.50 kit
- 01A-8418/22-HK Grille center strip hardware kit, deluxe only, mounts center strip and grille RH & LH sides to center plate panel, 13 pieces..... 1940 4.50 kit
- 01A-8242-HK Grille center hardware kit, standard only, mounts center to lower pan, upper brace & mounts safety catch, 15 pieces 1940 4.50 kit
- 51A-16046-K Fender to grille clip kit, set of 4 42-48 27.00 kit
- 51A-8170-HK Upper grille molding hardware kit. 46-48 18.00 kit



51A-16046-K



51A-8170-HK

GRILLE ASSEMBLY 1946-48 CAR

- 51A-8200-A Dies stamped steel with mounting holes for moldings 46-48 400.00 ea

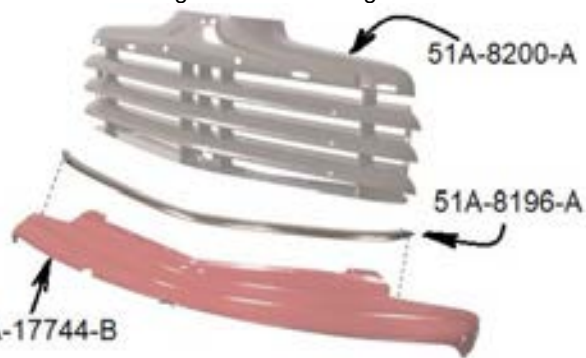

FRONT GRAVEL DEFLECTOR & TRIM

- 51A-17744-B Front gravel deflector, die stamped, 1 piece..... 46-48 200.00 ea
- 51A-8196-A Stainless trim for above 46-48 125.00 ea

GRILLE SHELL ORNAMENTS

DIE CAST CHROME PLATED

B-8215	Cars, by Vintique.....	1932	45.00 ea
	By Bob Drake.....	1932	50.00 ea
B-8215-BN	Passenger and pickup, use with filled shells, without radiator cap, uses B-8212-STR emblem, by Drake	1932	50.00 ea
40-8215	Passenger		
	By Vintique.....	1934	30.00 ea
	By Bob Drake.....	1934	50.00 ea



B-8215



B-8215-BN



40-8215

46-8215	Pickup		
	By Bob Drake.....	34-35	52.00 ea
48-8215	Passenger, by Bob Drake	1935	125.00 ea
67-8215	Pickup, by Bob Drake	1936	125.00 ea



46-8215



48-8215



67-8215

68-8215	Passenger, by Bob Drake	1936	ASK
68-8215-BN	Passenger, same as above except no V-8 ornament.....	1936	ASK



68-8215



68-8215-BN

77-8215	Pickup, by Bob Drake	1937	ASK
81C-8213	Pickup & commercial, by Bob Drake	1938	ASK



77-8215



81C-8213

"FORD" EMBLEMS FOR GRILLE SHELLS & ORNAMENTS- FORD BLUE AS ORIGINAL

B-8212-D	1932 car & 1932-1935 pickup * ...	32-35	40.00 ea
B-8212-STR	Use with B-8215-BN ornament....	1932	40.00 ea
40-8212-AR	1933 car *	1933	40.00 ea
40-8212-D	1934 car *	34-38	40.00 ea
48-8212-D	1935-1936 passenger, 1936 pickup & 1938 car, 90 HP *	35-38	40.00 ea

**These emblems also available in colors. White, red & black, Add -W, -R or -B to part number*



V8 GRILLE EMBLEMS

18-13122	Mounts on headlight bar		
	By Bob Drake	1932	35.00 ea
	By Vintique	1932	13.50 ea
40-8217-A	V-8 emblem, 1933 passenger & 1933-1934 pickup	33-34	20.00 ea



18-13122



40-8217-A

40-8221	V-8 emblem, passenger, blue painted insert.....	1934	ASK
78-8213-A	Passenger	1937	50.00 ea



40-8221



78-8213-A

HOOD EMBLEMS

46-16608	"V-8", die cast, chrome, pickup....	1934	26.00 ea
46-16606	Oval, die stamped, chrome with blue background, pickup.....	1934	125.00 pr
50-16606	Oval "V-8", die stamped, chrome, blue background, pickup.....	35-36	125.00 pr



46-16608



46-16606



50-16606

77-16606	Pickup.....	1937	85.00 pr
81A-16605/6	V8, deluxe.....	1938	50.00 pr
81A-8259-A	"85" ornament emblem	1938	40.00 ea



77-16606



81A-16605/6



81A-8259-A

HOOD EMBLEMS continued

01A-16604/5-B "V" & "8", front, standard passenger and pickup..... 1940 55.00 pr



01A-16604/5-B

91A-16606 "Ford" script, die cast, chrome, deluxe, also 1940 standard and 1940 pickup hood & dash 1939 12.50 ea

91A-16607 "Deluxe", die cast, chrome 1939 15.00 ea

01A-16606-C "Ford" script, die cast, chrome, Deluxe, border painted red..... 1940 14.00 ea

01A-16607-C "Deluxe", die cast, chrome, Deluxe, border painted red..... 1940 14.00 ea



11A-8218-B Emblem, chrome plated 1941 50.00 ea

51A-16605 "SPORTSMAN" emblem, convertible, chrome plated 46-48 18.00 ea

11C-16606-B "Ford" script, die stamped, chrome, pickup..... 1941 20.00 ea



11A-8218-B



51A-16605



11C-16606-B

11A-16606-A "V-8" front hood emblem, with hardware, passenger 1941 45.00 ea

51A-16607 "8" hood ornament emblem..... 1946 40.00 ea

6RA-16606-B Front hood emblem, "Super Deluxe" blue background 47-48 60.00 ea



11A-16606-A



51A-16607



6RA-16606-B

FRONT FENDER SCRIPT

11A-16079 "Super Deluxe" emblem 41-42 16.00 ea

51A-16079 "Super Deluxe" emblem 46-47 16.00 ea

Die cast chrome plated fits on left front fender below headlight



11A-16079



51A-16079

HOOD ORNAMENT & HANDLE 1937 CAR

DIE CAST CHROME PLATED

78-8218-K Ornament base & handle kit, car . . 1937 ASK

See next page for ornament gaskets



78-8218-K

HOOD ORNAMENT & HANDLE 1939-1940 CAR

DIE CAST CHROME PLATED

91A-8218-B Ornament only, Deluxe car..... 1939 145.00 ea

91A-8215-B Handle only, inset painted blue, Deluxe car 1939 ASK

1939 CAR DELUXE



91A-8215-B



91A-8218-B

01A-8218-A Ornament only, Standard car..... 1940 190.00 ea

01A-8215-A Handle only, Standard car 1940 50.00 ea

01A-8215/18-A Ornament with handle assembled, Standard car * 1940 ASK

01A-8218-B Ornament only, Deluxe car 1940 ASK

01A-8215-C Handle only, inset painted red, Deluxe car 1940 ASK

01A-8215/18-B Ornament with handle assembled Deluxe car * 1940 ASK

* These ornaments assemblies include 91A-8219 mounting Kit & 91A-8216-P handle pin

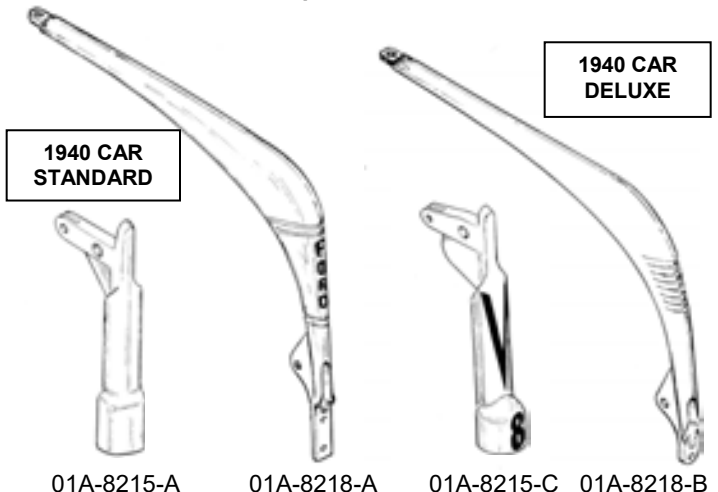

1940 CAR STANDARD

1940 CAR DELUXE

01A-8215-A

01A-8218-A

01A-8215-C

01A-8218-B

HOOD ORNAMENT & HANDLE 1940 PICKUP

DIE CAST CHROME PLATED

01C-8218	Ornament only, pickup	1940	ASK
01C-8215	Handle only, pickup.....	1940	ASK
01C-8215/18	Ornament with handle assembled, Pickup *	1940	ASK

*** This ornament assembly includes 91A-8219 mounting kit & 91A-8216-P handle pin**

1940 PICKUP

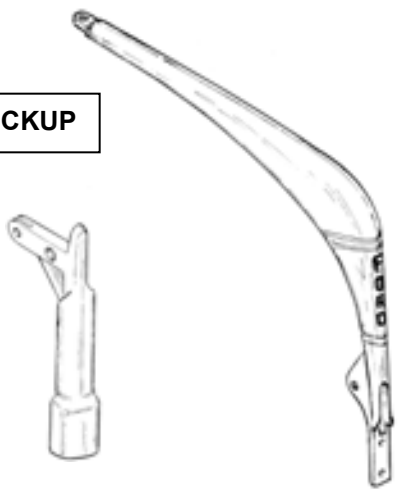

01C-8215

01C-8218

HOOD RELEASE HANDLE PIN & ORNAMENT HARDWARE

91A-8216-P	Hood release handle pin, 1939-1940 passenger & 40-41 pickup ..	39-41	4.00 ea
91A-8219	Hood ornament mounting hardware kit*	39-41	21.00 kit

***Note: Kit 91A-8219 is not included with the above ornaments.**



91A-8216-P



91A-8219

HOOD LATCH TENSION SPRINGS

91A-8223	Deluxe.....	1939	14.00 set
01A-8223-B	Deluxe.....	1940	14.00 set
01A-8223-A	1940 standard & 1940-1941 pickup	40-41	10.00 set



91A-8223



01A-8223-B



01A-8223-A

HOOD ORNAMENT GASKETS

78-8227	Passenger, use with 78-8218	1937	2.00 ea
81A-8227-A	Standard.....	1938	2.00 ea
81A-8227-B	Deluxe	1938	2.00 ea



78-8227

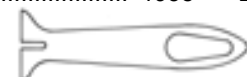

81A-8227-A



81A-8227-B

HOOD ORNAMENT 1947-1948

6A-16607	Blue plastic insert only	47-48	15.00 ea
6A-16851	Hood ornament <u>without</u> insert.....	47-48	135.00 ea
6A-16851-K	With blue plastic insert, extra nice quality by Bob Drake ...	47-48	250.00 ea



6A-16607



6A-16851

BUMPER GRILLE GUARDS

40-17799	Passenger, chrome, includes brackets and hardware, 9 pieces	33-36	65.00 set
01A-18412	1940 passenger & Mercury and 1940-1941 pickup, chrome plated with FORD script, includes hardware & Stiffeners, Requires (2) 01A-17796 bumper guards (not included) for installation.....	40-41	ASK

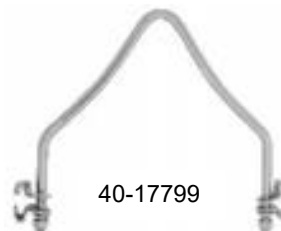

40-17799



01A-18412

HOOD HINGE RETAINER BRACKETS

B-8221	Passenger & pickup (rear), chrome plated.....	1932	17.00 ea
B-8221-S	Same as above exc. stainless steel.	1932	25.00 ea
B-8220-S	1932 passenger & pickup (front), 1933-1935 passenger (front), 1933-1936 passenger (rear), stainless steel.....	32-36	16.00 ea
68-8226	Passenger (front), zinc plated.....	1936	7.00 ea
46-8220	Pickup (front), stainless steel.....	33-34	19.00 ea
46-8221	Pickup (rear), cast stainless steel.....	33-34	19.00 ea
46-8220-A	Pickup (front & rear), stamped chrome plated.....	35-37	10.00 ea
46-8220-A-D	Same as 46-8220-A except stainless steel.....	35-37	20.00 ea



B-8221



B-8220



68-8226



46-8220



46-8221



46-8220-A

HOOD CENTER HINGES

B-16632-D	Stainless steel, 32" long, passenger & pickup	1932	40.00 ea
40-16632-D	Stainless steel, 33" long, cars	33-36	40.00 ea
46-16736	Stainless steel, pickup	33-34	120.00 ea
67-16736	Stainless steel, pickup	35-37	120.00 ea
40-16630/1	Steel inner hood hinge that is spot welded to the hood, 31.25" long, sold in pairs, cars only.....	33-36	40.00 pr

Center hinge Hinge rod 40-16630/1 B-16632 or 40-16632



HOOD HINGE ROD - STAINLESS STEEL

B-16736	30.5" long, passenger & pickup....	1932	10.00 ea
40-16736	39" long, passenger	33-36	10.00 ea
48-16736	38" long, pickup.....	33-37	10.00 ea

HOOD & RADIATOR SHELL LACING - NON ORIGINAL

Offered as an alternative to the original style lacings (next section). These are sponge rubber with pressure sensitive adhesive on back. Four different versions and sizes.

Rectangular shape, solid sponge rubber with ribbed surface
 HR-16739 3/8" wide x 3/16" thick x 8' roll..... 8.00 roll
 HR-16740 5/8" wide x 3/8" thick x 8' roll..... 9.00 roll
Half round shape, hollow core sponge rubber, smooth surface

SR-16739	3/8" wide x 3/16" thick x 8' roll.....	8.00 roll
SR-16740	5/8" wide x 3/8" thick x 8' roll.....	9.00 roll

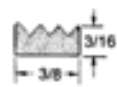

HR-16739

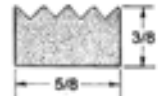

HR-16740



SR-16739



SR-16740

RADIATOR SHELL LACING KITS

B-16739-S	Cloth with clips, 1932 passenger and 1932-1934 pickup	32-34	10.00 kit
40-16739-S	Cloth with rivets, passenger.....	33-34	10.00 kit
48-16739-S	Cloth with rivets, passenger.....	1935	10.00 kit
50-16739-S	Cloth with rivets, pickup.....	35-37	12.50 kit
68-16739-S	Rubber with rivets, passenger	1936	7.00 kit
81C-16739-S	Rubber with rivets, pickup	38-39	10.00 kit

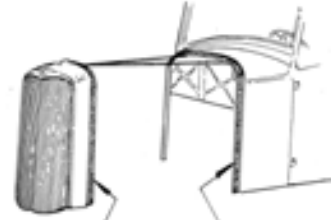

Radiator shell lacing

Cowl Lacing

COWL LACING KITS

B-16740-S	Cloth with clips, 1932 passenger and 1932-1934 pickup	32-34	13.00 kit
40-16740-S	Cloth with screws, passenger	33-34	12.00 kit
48-16740-S	Cloth with screws, 1935 passenger & 1935-1937 pickup ...	35-37	11.00 kit
68-16740-S	Cloth with screws, passenger	1936	10.00 kit
78-16740-S	Rubber with screws, 1937-1940 passenger & 1938-1941 pickup ...	37-41	10.00 kit
11A-16740-S	Rubber with screws, passenger...	41-48	10.00 kit
21C-16740-S	Cloth with screws, pickup	42-56	15.00 kit

FIREWALL TO COWL SEAL

B-35336	Extruded rubber	1932	15.00 ea
---------	-----------------------	------	----------



B-35336

HOOD PROP KIT

A-16613-SS	Eliminates resting hood on cowl, polished stainless steel	25.00 kit
------------	---	-----------



HOOD BUMPER BRACKETS

B-16761-SS	Car & 32-34 pickup, stainless steel *	1932	ASK
68-16628-K	Car, front, painted black **	1936	ASK
68-16628-KS	Car, front, stainless steel **	1936	ASK
68-16759-K	Car, rear, painted black **	1936	20.00 pr
68-16759-KS	Car, rear, stainless steel **	1936	30.00 pr

* Bumper not included, order B-16761-S bumper set

** Bumper included



B-16761-SS



68-16628-K



68-16759-K

HOOD RUBBER BUMPER SETS

- B-16761-S 12 pieces, also 1932-34 pickup.... 32-34 9.50 set
- 40-16761-S 14 pieces, passenger 33-34 9.50 set

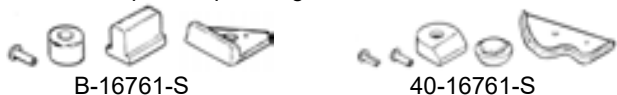

- 48-16761-S 16 pieces, 1935 passenger and 1935-1937 pickup 35-37 12.50 set
- 68-16761-S 26 pieces, passenger 1936 12.50 set



- 78-16761-S 20 pieces, passenger 1937 9.50 set
- 81A-16761-S 14 pieces, standard & pickup 38-39 9.50 set



- 91A-16761-S 14 pieces, 1939 deluxe and 1940 all passenger 39-40 12.00 set
- 01C-16761-S 14 pieces, pickup 40-41 12.50 set



- 11A-16761-S 12 pieces, passenger 41-48 9.50 set
- 21C-16761-S 12 pieces, pickup 42-47 9.50 set



- 7C-16761 9 pieces, pickup 1948 8.50 set

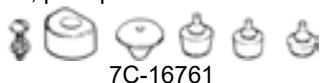

HOOD TO GRILLE CATCH BRACKETS

- 40-16628-B 4 pieces & hardware 1933 20.00 set
- 40-16628-C 4 pieces & hardware 1934 20.00 set



HOOD SIDE FENDER / APRON MOUNTING KIT

- 81A-16750-RK 1938 Deluxe, 38-39 Standard (can also be used on Pickups) . 38-39 39.00 kit

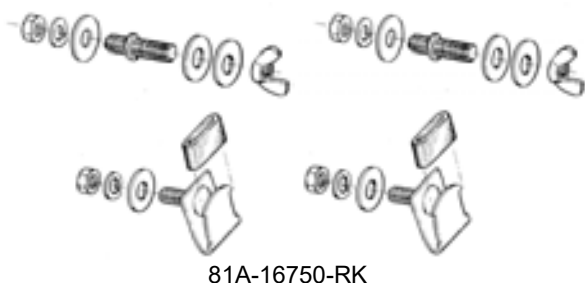

81A-16750-RK

HOOD LATCHES & PARTS

- B-16750-BK Black, 1932 passenger and 1932-1934 pickup 32-34 12.00 ea
- B-16750-SS Stainless steel, 1932 passenger and 1932-1934 pickup 32-34 18.00 ea
- 48-702356 Hood latch pads for above 32-34 2.00 pr
- B-16750-BD Black body, stainless steel finger pull, 1932 passenger and 1932-1934 pickup, SET OF (4) * 32-34 90.00 ea
- B-16750-SS-BD Same as B-16750-BD except all stainless steel* 32-34 125.00 ea
- B-16750-R Hood latch pads for -BD latches set of 4 32-34 15.00 pr
- B-16750-SK Hood latch screw kit, all stainless steel, does 4 latches 32-34 5.00 kit

*These items by Bob Drake & duplicates of the original



B-16750 B-16750-R



B-16750-SK

HOOD HANDLES & PARTS

- B-16636 Pressed steel, painted black, set includes 2 handles, threaded rivets & nuts, 1932 passenger and 1932-1934 pickup 32-34 23.00 set
- B-16636-S Set as above, except polished stainless steel 32-34 32.00 set
- 40-16636-A Die cast chrome, passenger 1933 95.00 pr
- 48-16644/5-B Stainless steel, set of 4, 1935-1936 passenger & 1935-1937 pickup, also fits 1934 passenger . 35-37 150.00 set
- 40-16658-K Hood spring bracket assemblies, set of 4, car 1934 70.00 set
- 48-16658-K Hood spring bracket assembly, 1935-36 cars & 1935-36 pickups . 35-36 70.00 set



B-16636 48-16644/5-B 40-16636-A 40-16658-K & 48-16658-K

HOOD SIDE PANEL CLIPS

- 18-16750-SS Rubber bumpers and special threaded rivets, stainless steel, 1932 passenger and 1932-1934 commercial 32-34 50.00 set
- 18-16750 Clips as above except painted black 32-34 40.00 set
- A-16755 Threaded rivet set only, set of (20) 8-32 x 1/4" with nuts, stainless steel 28-34 5.00 set

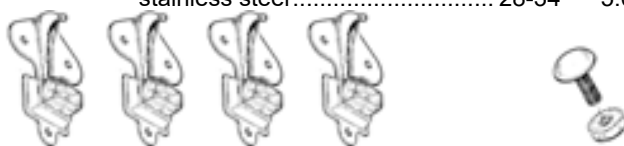

18-16750 A-16755

HOOD CROSSBRACE HARDWARE KIT

01A-16774-BHK Passenger & pickup, 24 pieces.. 1940 8.00 kit

HOOD RELEASE LINKAGE & SUPPORT BRACE KITS

Includes hood catch lever, rear hood brace, hood latch check & tension springs, hood lever hardware kit & front hood brace.

91A-16674-K 1939 Deluxe cars1939 60.00 kit
 01A-16674-AK 1940 Std cars, 1940-41 pickup40-41 60.00 kit
 01A-16674-BK 1940 Deluxe cars..... 1940 60.00 kit



HOOD PULL CABLE

6A-16916 Cut to length, no knob.....41-48 20.00 ea



HOOD ARM & SPRING SUPPORT & PARTS

Painted black or stainless steel

91A-16782/3 1939-47 pickup, 1939 std cars, 1941-48 cars **Painted black**39-48 50.00 pr
 91A-16782/3-SS Same as 91A-16782/3 except polished **stainless steel**.....39-48 80.00 pr
 91A-16802/3 1939 Dlx cars, 1940 all cars & 41 sedan delivery, **Painted black** 39-40 75.00 pr
 91A-16802/3-SS Same as 91A-16802/3 except polished **stainless steel**.....39-40 90.00 pr
 51A-16782/3-SS 1942-48 cars & 1942-47 pickup **stainless steel** by Drake42-48 125.00 pr
 91A-16789 Hood arm spring, **plain steel** *.....39-48 8.00 ea
 91A-16789-SS Hood arm spring, **stainless steel** * 39-48 12.00 ea
 *NOTE: 91A-16789 springs included in above hood arm supports

91A-16794/5-C Hood arm body brackets, fastens to hood, 1939 Dlx & 1940 car.....39-40 35.00 pr
 91A-16610 Hood hinge shoulder bolt with spring washer, hex head, 1/4-28 fine thread, black oxide39-48 3.00 ea
 91A-16610-SS Bolt as above but stainless steel..... 39-48 4.50 ea
 91A-16612-A Hood arm shoulder bolt with spring washer, slotted head 1/4-20 thread, cad plated finish.....39-48 5.00 pr
 91A-16612-SS Bolts as above but stainless steel..... 39-48 9.00 pr

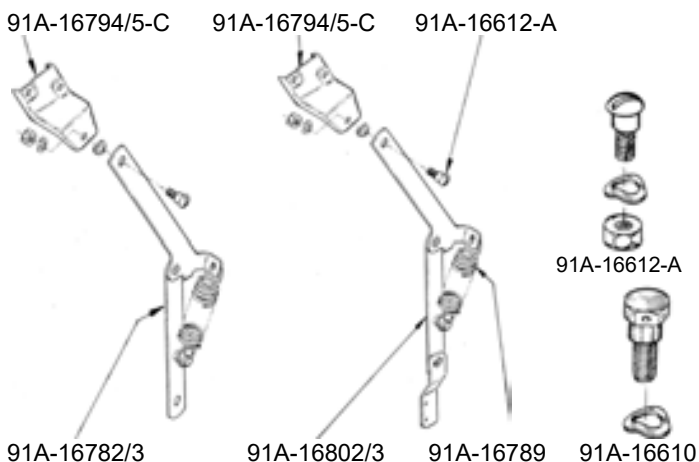

HOOD HINGE BRACKETS

Powder coated black or stainless steel

78-16796/7-S Cars, **Painted black** 1937 45.00 pr
 78-16796/7-SST Cars as above except stainless steel 1937 80.00 pr
 91A-16796/7- 1938-1940 passenger, 1940-1941 -S sedan delivery, **Painted black**..... 38-41 65.00 pr
 91A-16796/7 Same as 91A-16796/7 except -SST **stainless steel** 38-41 80.00 pr
 01C-16796/7-S Pickup, **Painted black** 40-47 40.00 pr
 01C-16796/7 Same as 01C-16796/7 except -SST **stainless steel**..... 40-47 48.00 pr
 21A-16796/7 Late 1941 passenger & 1942-1948 passenger, **Painted black**.. 41-48 60.00 pr
 21A-16796/7- Same as 21A-16796/7 except -SST **stainless steel**..... 41-48 80.00 pr



HOOD HINGE PADS

78-16746/7-S Molded rubber with shoulders, cars only 37-40 4.50 pr

HOOD HINGE HARDWARE

Attaches hinge brackets to hood

91A-16796-HK Special hex head bolts with hole through head for wire, set of 4 with spring steel washers, use with 91A-16796/7..... 37-40 7.00 set



91A-16796-HK

HOOD SAFETY CATCH & SPRING

01A-16892-A Standard, 1940-1941 pickup 40-41 N/A
 01A-16892-AS Standard, 1940-1941 pickup, polished stainless steel 40-41 50.00 ea
 01A-16892-B Deluxe 1940 40.00 ea
 01A-16892-BS Deluxe, polished stainless steel 1940 50.00 ea
 11A-16897 Spring & pin only, cars 41-42 10.00 kit
 51A-16897 Spring & pin only, cars 46-48 10.00 kit



01A-16892 01A-16892 11A-16897 & 51A-16897

FENDER BOLTS & WASHERS

A-16713/14-SK	Front fender to frame kit, 4 stainless screws with nuts	28-32	2.50 kit
B-16026-BK	Front fender to brace bolt set with 2 special head bolts & nuts	28-34	1.50 set
B-16026-SS	Bolt set as above except stainless steel.....	28-34	2.00 set
48-16007-SK	Fender bolts, cad plated, set of 18.....	35-48	6.00 set
48-16008-SK	Washer kit, 56 pieces, rubber and metal.....	35-36	9.00 kit
91A-16008-SK	Washer kit, 60 pieces, rubber and metal.....	37-40	13.00 kit

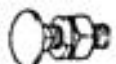

B-16026



48-16007-SK



48- & 91A-16008-SK

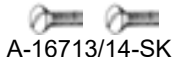

01A-16009	Rear fender to body clip, car	39-40	2.25 ea
01A-16009-K	Above clips in set of 18.....	39-40	36.00 set
78-16082-HK	Fender to apron bolt set, special low head, black oxide finish, cars only, set of 12 bolts with nuts & washers, cars only	1937	15.00 kit
20367-S2	Fender to apron bolt set, as above except for 1939-1940 cars and 1940-1941 pickup, 8 bolts with nuts & lock washers	39-41	15.00 set
B-16007-SK-10	Rear fender stud set, special flat head stud, mounts fenders to the side of the bed, black oxide finish, pickup only, set of 10	28-72	10.00 set
78-16341-HK	Rear fender brace hardware kit. Includes special molded rubber Washers. Does both fenders	37-40	10.00 kit



01A-16009



B-16007-SK



78-16082-HK
20367-S2



78-16341-HK

COWL TO FENDER SEALS-PICKUPS

21C-16068	Extruded rubber.....	42-47	15.00 pr
7C-16068	Sponge rubber.....	48-52	15.00 pr

Cowl to fender seals

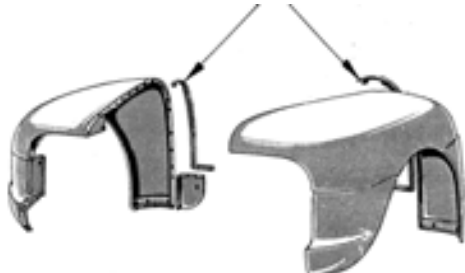

FENDER WELTING-BLACK

B-16070-20	Crushed grain vinyl, with 3/16" bead, 20' roll.....	28-56	12.00 ea
B-16070-30	Welting as above except 30' roll ..	28-56	18.00 ea
40-16070-A	Crushed grain vinyl, with 1/4" bead, 25' roll.....	28-56	12.00 ea
48-16070	Rubber with 1/4" bead, used on pickup truck rear fenders, 10' roll.	48-56	16.00 ea
B-5010-A	Webbing/anti-squeak, flat, used on some pickup truck front fenders 1" x 1/16" x 25' roll	48-56	18.00 roll



B-16070, 40-16070



48-16070

FENDER WELTING-COLORED

Crushed grain vinyl, 3/16" bead, 25' roll

B-16070-CH	Chrome like.....	28-56	18.00 ea
B-16070-MR	Maroon.....	28-56	ASK
B-16070-CR	Caramel	28-56	28.00 ea
B-16070-OR	Bright Orange.....	28-56	28.00 ea
B-16070-BLM	Medium Blue	28-56	28.00 ea
B-16070-BRD	Dark Brown	28-56	28.00 ea
B-16070-GRD	Dark Green	28-56	ASK
B-16070-RD	Red	28-56	28.00 ea
B-16070-RR	Bright Red.....	28-56	28.00 ea
B-16070-WH	White.....	28-56	28.00 ea
B-16070-GY	Gray.....	28-56	28.00 ea
B-16070-YL	Bright Yellow	28-56	ASK

COLOR SAMPLES OF ABOVE AVAILABLE UPON REQUEST



FENDER-GRILLE- APRON WELTING/WEBBING KIT

Kit includes precut pieces with all notches & holes of black welting for between grille sides, front fenders to cowl & rear fenders to quarter. Also, anti squeak webbing to fit between front fenders and aprons. **A BIG TIME SAVER!**

48-5010-B	1935 cars	1935	60.00 kit
68-5010-B	1936 cars	1936	70.00 kit
78-5010-B	1937 cars	1937	70.00 kit
91A-5010-B	1939 Deluxe & 1940 car	39-40	70.00 kit
01C-5010-B	1940-1941 pickup	40-41	70.00 kit
91A-5010-C	Running board to frame welting, precut, 1935-40 cars & 1940-41 pickups	35-40	25.00 kit



FRONT FENDER BRACES-SMALL

40-16025	Passenger, RH or LH	33-34	30.00 ea
48-16025	Passenger, RH or LH	35-36	30.00 ea



50-16025	Pickup, RH or LH.....	35-37	30.00 ea
78-16025	1937-1938 passenger and 1939 standard, RH or LH.....	37-39	30.00 ea



81C-16025	Pickup RH or LH.....	38-39	30.00 ea
01C-16094	Pickup, RH and LH.....	40-41	30.00 pr



LARGE FRONT FENDER BRACE REINFORCEMENT BRACKETS

40-16067-B	RH or LH, frame to large brace.....	33-34	10.00 ea
48-16067	RH, 1935-1938 passenger, also 1939 standard & 1937-1939 pickup, frame to main brace.....	35-38	14.00 ea
48-16068	LH, 1935-1938 passenger, also 1939 standard & 1937-1939 pickup, frame to main brace.....	35-38	14.00 ea



40-16067-B, 48-16067 & 48-16068

B-16025	RH or LH, stamped steel	1932	41.00 ea
40-16047/8	RH and LH, stamped steel	33-34	90.00 pr
68-16047	RH, stamped steel.....	1936	ASK
68-16048	LH, stamped steel	1936	ASK

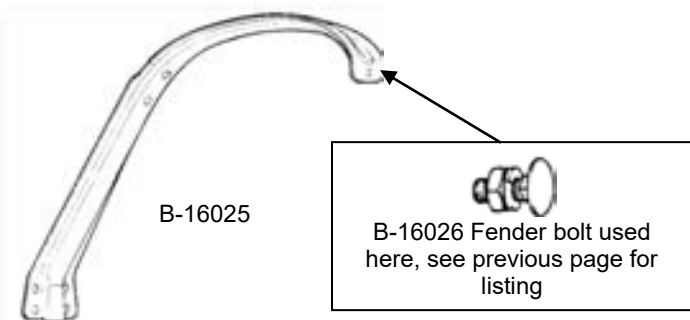

REAR FENDER BRACES-SMALL

These braces fit just in the rear of the wheel opening.

B-16341	Late 1932 & 1933-34 pickup RH or LH.....	32-34	30.00 ea
40-13463	Passenger, RH or LH.....	33-34	20.00 ea



B-16341

40-13463

48-16180	Passenger, RH or LH.....	35-36	30.00 ea
50-16180	1935-1936 pickup, RH or LH....	35-36	30.00 ea



48-16180

50-16180

67-16341	Pickup, RH or LH	1937	30.00 ea
78-16180	Passenger, RH or LH.....	37-41	30.00 ea



67-16341

78-16180

81C-16180	Pickup, RH or LH	38-41	30.00 ea
21C-16340-C	Pickup, RH or LH	42-47	30.00 ea



81C-16180

21C-16340-C

REAR FENDER PATCH PANELS

48-16160-RP	Right rear fender repair section, stamped steel, passenger.....	35-40	100.00 ea
48-16161-RP	Left rear fender repair section, stamped steel, passenger.....	35-40	100.00 ea

Note: These patch panels require alterations to fit 1937-40 fenders

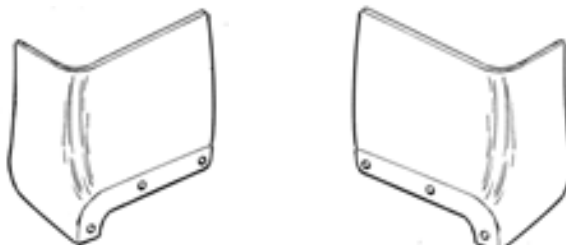

48-16160-RP

48-16161-RP

FENDER BRACE PANELS

Fit behind each wheel, protecting the inner fender as well as supporting it, painted black.

91A-16088/9	1939 deluxe, 1940 passenger and 1940-1941 pickup, front, RH and LH.....	39-41	75.00 pr
21A-16094	Passenger, front, RH & LH.....	42-48	75.00 pr
11A-16094-A	Passenger, front, RH & LH.....	1941	75.00 pr
21A-16341-A	Passenger, left rear.....	42-48	60.00 ea
11A-16340-A	Passenger, right rear.....	41-48	40.00 ea

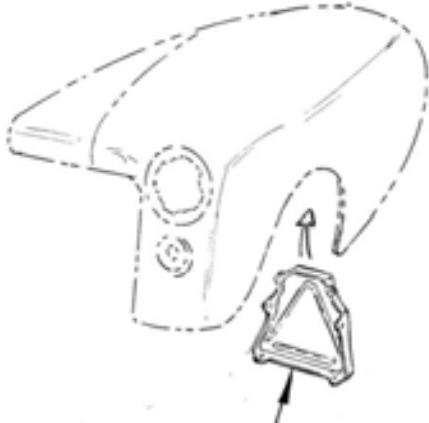

Front fender brace panel
21A-16094 shown



91A-16088/9



11A-16094-A



Rear fender brace panel 21A-8104-R Seal
21A-16341-A Shown



11A-16340-A

FENDER BRACE PANEL SEAL

Fits around the rear fender brace panel with enough left to be used as a seal around the radiator deflector panel, RH and LH, sold as a kit. See illustration above.

21A-8104-R	RH & LH, sponge rubber.....	42-48	8.00 kit
------------	-----------------------------	-------	----------

FRONT FENDER TIE BRACKETS

Joins the two front fenders together below the grille.

40-16088-B	Black, with hardware.....	33-34	18.00 ea
40-16088-C	Chrome, with hardware.....	33-34	22.00 ea
40-16088-SS	Stainless steel, with hardware..	33-34	45.00 ea



40-16088

HORN GRILLE COVER AND PADS

68-16156-A	Horn grille cover with 68-16156 pads, stainless steel.....	1936	50.00 pr
68-16156-S	Pads only for above horn covers, pair.....	1936	7.00 pr

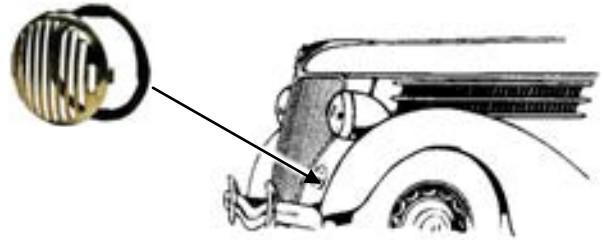

REAR FENDER BOOTS/STONE GUARDS

21A-16349/50-A	Rubber molded over steel, all styles except station wagon	42-48	85.00 pr
51A-16349/50-SS	As above except polished stainless steel in place of rubber cover.....	42-48	ASK

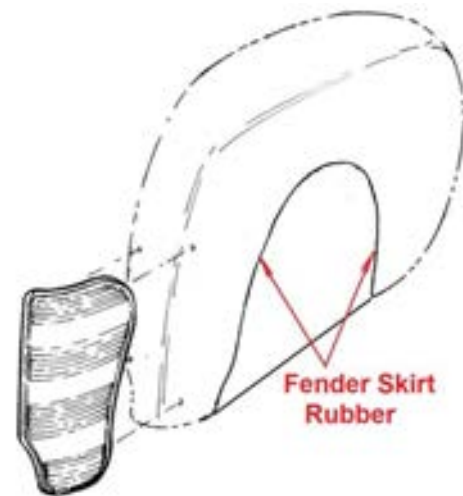

21A-16349/50-A

FENDER SKIRT RUBBER-Original skirts only

78-18990	Fender skirt seal.....	37-39	25.00 pr
01A-18990	Fender skirt rubber.....	40-48	10.00 pr

FRONT FENDER INNER APRON PANELS

78-16082/3 Cars, original design with louvers.....1937 395.00 pr



78-16082/3

01A-16082/3 1939 Deluxe, 1940 Deluxe & Standard, 1940-41 pickup original design39-41 210.00 pr

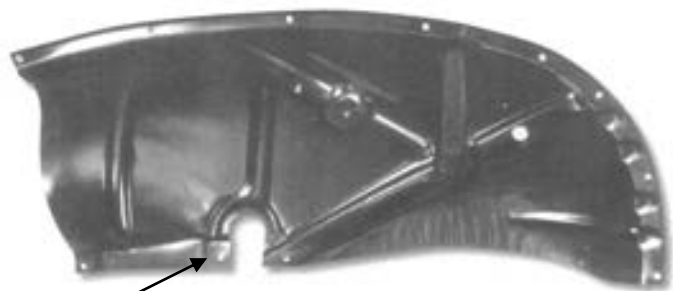

01A-16082/3



01A-16188 Bumpers also available, see below

01A-16082/3-M Same as above except cut for leading manufacturer's Mustang II front end kits.....39-41 210.00 pr

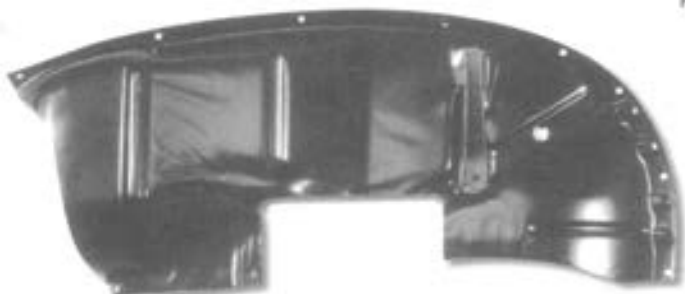

01A-16082/3-M

FRONT FENDER INNER APRON TO FRAME BUMPERS

01A-16188 1940 passenger 1940-41 pickups & 1939 deluxe, set of 4.....39-40 3.50 set
 21A-16188 Passenger, set of 642-48 4.50 set



01A-16188



21A-16188

FRONT FENDER INNER APRON PANEL SUPPORT

01A-16138-A Front fender apron support for aprons to front crossmember. NOS, 1939 Del 1940 Deluxe & Standard 1940-41 pickup 39-41 ASK



REAR FENDERS-CARS

1936 Coupe, Roadster & Cabriolet

68-16160-A RH, rear 1936 N/A
 68-16161 LH, rear 1936 N/A
 68-16160/1 RH & LH..... 1936 N/A

FRONT FENDERS-CARS

Fits 1939 Deluxe, 1940 Standard & Deluxe

01A-16005 RH, front.....39-40 850.00 ea
 01A-16006 LH, front.....39-40 850.00 ea
 01A-16005-PR RH & LH.....39-40 1600.00 pr



REAR FENDERS-CARS

1938 Deluxe, 1939 Standard & Deluxe, 2 Dr & 4 Dr sedan, all except station wagon & sedan delivery

81A-16312-C RH, rear38-39 800.00 ea
 81A-16313-C LH, rear38-39 800.00 ea
 81A-16312-PR RH & LH.....38-39 1500.00 pr

1940 Standard & Deluxe, 2 Dr & 4 Dr sedan, all except station wagon & sedan delivery

01A-16312-B RH, rear 1940 800.00 ea
 01A-16313-B LH, rear 1940 800.00 ea
 01A-16312-PR RH & LH..... 1940 1500.00 pr



81A-16312-C



01A-16313-B

ABOVE FENDERS SHIP BY TRUCK FREIGHT

RUNNING BOARDS-PASSENGER CARS

Covered boards are vulcanized rubber -as original

Passenger, covered, car & pickup

- B-16450/1-V By Vintique1932 525.00 pr
- B-16450/1-BD B y Drake.....1932 875.00 pr



- 40-16450/1-BD Passenger, covered 33-34 1225.00 pr



- 48-16450/1-BD Passenger, covered 35-36 1225.00 pr



- 78-16450/1-BD 1937-1938 passenger & 1939 Standard, covered 37-39 1225.00 pr



- 91A-16450/1-BD 1940 passenger, also 1939 Deluxe, covered 39-40 1225.00 pr



NOTE: WE FREQUENTLY CAN OFFER SPECIAL PRICING ON THE ABOVE IN STOCK RUNNING BOARDS-PLEASE CALL!

RUNNING BOARDS – PICKUP

- 01C-16450/1 Die stamped steel with braces 40-41 700.00 pr



01C-16450/1

RUNNING BOARD BRACES

- B-16485-S Steel, set of 4 1932 27.50 set
- 40-16485-S Steel, set of 4 33-34 22.50 set



B-16485-S



40-16485-S

RUNNING BOARD RUBBER COVER SETS

Kits are top quality rubber with 2 pints of adhesive and installation instructions.

- B-16450/1 Passenger & pickup 1932 235.00 pr
- 40-16450/1 Passenger..... 33-34 260.00 pr
- 48-16450/1 Passenger..... 35-36 260.00 pr
- 78-16450/1 1937-1938 passenger, also 1939 standard 37-39 260.00 pr
- 91A-16450/1 1940 passenger, also 1939 Deluxe 39-40 260.00 pr
- 11A-16450/1 Passenger..... 1941 260.00 pr
- 21A-16450/1 Passenger..... 42-48 260.00 pr
- G-16450 Pint of adhesive (extra if needed)..... 32-48 14.00 ea



91A-16450/1

RUNNING BOARD BOLTS & GROMMETS

- B-16450-MB Bolt kit, 118 pieces 1932 17.00 kit
- 40-16450-MB Bolt kit, 114 pieces 33-34 14.75 kit
- 21A-16458-S Running board to frame rubber grommets, set of 24 plus washers..... 42-48 15.00 kit
- 78-16453 Running board bolts, attach board to frame, special low head, cad plated finish 35-48 1.00 ea
- 78-16453-S Set of 24..... 35-48 12.00 set



78-16453



21A-16458

RUMBLE SEAT STEP PADS & BRACKETS

B-41563	Step pad, large pyramid style.....	32-34	15.00 ea
B-2454	Step pad, fits on tail light stand	33-34	32.00 ea
40-41564-B	Step brace, fits under fender.....	33-34	7.50 ea
40-2454	Step pad, fits on tail light stand or fender.....	35-36	8.50 ea
78-2454	Step pad, fits on fender.....	37-39	8.50 ea



B-2454 & 40-2454



78-2454

RUMBLE SEAT GRAB HANDLES

Polished stainless steel handles with cast chrome plated posts, By Vintique.

B-41500-SS	All mounting hardware included ...	28-32	36.00 ea
------------	------------------------------------	-------	----------



RUMBLE LID BUMPER STOP KIT & BRACKETS

B-41484-S	Rubber bumper & stop set, upper & lower, 4 piece kit with hardware	32-34	8.50 kit
B-714008-S	Stop bracket, steel, 1 pair 5W & Roadster	1932	14.00 pr
40-714008-S	Stop bracket, steel, 1 pair 1932 3W & 1933-1939	32-39	14.00 pr
B-41519	Bumper brackets, steel, fit in top corners of rumble area	33-34	12.50 pr



B-41484-S



B-714008



40-714008

RUMBLE SEAT HINGE KITS

All kits include special shoulder bolts, washers & screws. By Vintique.

B-41543-S	Roadster & 5-window coupe.....	1932	55.00 kit
40-41543-S	Coupe, roadster & cabriolet.....	33-34	ASK
48-41543-S	Coupe, roadster & cabriolet.....	35-36	55.00 kit



B-41543-S



48-41543-S

RUMBLE SEAT CLIPS & HANGERS

40-41551-L	Lower seat clips to mount rumble cushion to lid	33-34	10.00 pr
40-41550-U	Upper seat clips to mount rumble cushion to lid	33-34	10.00 pr



40-41551-L

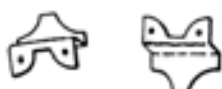

40-41550-U

RUMBLE & TRUNK LID MISCELLANEOUS PARTS

B-526812	Rumble hinge spring bracket, mounts inside of body, has holes for spring adjustment	33-34	13.00 pr
B-526813	Rumble seat remote trip spring, 1932 3-window coupe, 1933-1934 coupe, roadster & cabriolet and 1938-1939 convertible coupe....	32-39	N/A
B-526814	Rumble seat remote trip lever, 1932 3-window coupe, 1933-1934 coupe, roadster & cabriolet and 1938-1939 convertible coupe...	32-39	N/A



B-526812



B-526813



B-526814

B-526898	Rumble hinge spacers, steel, 1932 3-window coupe, 1933-1934 coupe, roadster and cabriolet & 1938-1939 convertible coupe	32-39	12.00 pr
40-725900	Rumble seat release handle, 1932 3-window coupe, 1933-1934 coupe, roadster and cabriolet, chrome	32-34	18.00 ea
A-41543-MK	Rumble seat hinge mounting kit, includes special shoulder bolts & washers for rumble seat hinge pivot & screws to mount deck lid to hinges	28-32	8.00 kit



B-526898



40-725900



A-41543-MK

A-41512-S	Trunk lid hinge, includes mounting plates & special shoulder bolts.....	28-32	14.00 set
40-775600	Remote control rod & release mechanism, coupe.....	33-34	35.00 ea
48-725854	Trunk drain hoses, without rumble seat, coupe	35-36	6.00 pr



A-41512-S



40-775600

RUMBLE & TRUNK LID LOCKING HANDLES 1932-1937

40-702352	1932-1934 deck or 1933-1934 roadster rumble, chrome	32-34	35.00 ea
48-702352-B	1935-1936 deck lid & rumble handle, chrome, with 2 keys.....	35-36	35.00 ea
78-702352	Blue background, with 2 keys ..	1937	35.00 ea



40-702352



48-702352-B



78-702352

A-41606-N	Rumble & trunk lid handle acorn nut & special washer	32-37	2.50 ea
A-702356-E	Rumble & deck lid handle rubber pad.....	32-37	2.50 ea



A-41606



A-702356-E

TRUNK LID RUBBER BUMPERS

B-41518	Upper deck lid & rumble	32-34	5.00 pr
01A-7243800	Coupe & convertible	39-40	3.00 pr
11A-7243800	Coupe & convertible	41-48	3.00 pr



B-41518



01A-7243800



11A-7243800

TRUNK & RUMBLE LID STRIKER PLATES 1928-1934

A-41615	Trunk lid striker plate, steel.....	28-32	6.50 ea
A-41506	Rumble lid adjustment plates, 5-window coupe & roadster, aluminum.....	1932	4.00 pr
A-52500-S	Rumble lock striker plate	1932	3.00 ea
B-765680	Rumble lid striker plate, 3-window coupe, cast iron	1932	9.00 ea
40-52500-A	Trunk lid striker, stamped steel.	33-34	14.00 ea
48-765680	Rumble lid striker plate, bronze.	35-36	ASK



A-41615



A-41506



A-52500-S



B-765680



48-765680

TRUNK LATCH STRIKER KITS 1935-1948

48-713780-B	1935-1936 coupe & 1936 Club cabriolet *	35-36	35.00 kit
78-725680	1937-1938 Coupe *	37-38	ASK
78-706990-A	1937-1939 Tudor & Fordor 1939 Convertible Sedan *	37-39	35.00 kit
01A-7043252	1940 Tudor & Fordor *	1940	35.00 kit
01A-52500-A	1939-1940 Coupe & 1940 Convertible *	39-40	35.00 kit
11A-7043252	Tudor & Fordor *	41-48	ASK
11A-7243252	Coupe & Convertible *	41-48	35.00 kit

* Polished stainless steel with installation hardware



48-713780-B



78-725680



78-706990-A



01A-7043252



01A-52500-A



11A-7043252



11A-7243252

DECK OR RUMBLE LID LATCHES

A-52501	Trunk lid latch, 1" tall collar By Vintique	28-32	12.00 ea
	By Drake.....	28-32	30.00 ea
A-52502	Rumble lid latch, 30-34 Roadster & 30-32 5W coupe rumble. 32 3W & 33-34 Roadster & coupe trunk By Vintique	30-34	12.00 ea
	By Drake.....	30-34	30.00 ea
B-527102	Rumble lid latch, mounts inside body under drip rail, also 1932 3-window coupe	32-34	24.00 ea



A-52501



A-52502



B-527102

DECK OR RUMBLE LID LATCHES continued

B-527103	Rumble latch mounting bracket	33-34	12.00 ea
48-52502	Deck or rumble lid latch, all bodies	35-36	25.00 ea
78-52502	Deck or rumble lid latch, all bodies	1937	25.00 ea
01A-52502-A	Deck lid latch, 1939-1940 coupe & 1940 convertible.....	39-40	ASK
01A-52502-B	Deck lid latch, sedan	1940	30.00 ea
11A-52502	Deck lid latch, sedan	41-48	30.00 ea
21A-52502	Deck lid latch, coupe and convertible.....	42-48	30.00 ea



B-527103



01A-52502-B



11A-52502

TRUNK LID HINGES

48-713570-AS	Stainless steel arms, cast steel base, cpe, cabriolet & roadster	35-36	ASK
48-706850/1	Humpback, chrome	35-36	90.00 pr
48-706902/4	Trunk hinge lock set.....	35-36	195.00 set
78-706850/1-A	Flatback, tudor & fordor, chrome.....	1937	150.00 pr
78-706850/1-B	Humpback, tudor & fordor, chrome	1937	150.00 pr
91A-7742700-PR	Plain steel, coupe	39-40	125.00 pr
01A-6642700	Stainless steel arms, conv*	39-40	100.00 pr
21A-7642700	Stainless steel arms, coupe & convertible*	41-48	100.00 pr

* These have gloss black stamped steel bases



48-706902/4



48-706850/1



78-706850/1-A



78-706850/1-B



91A-7742700



01A-6642700



21A-7642700

TRUNK LID HINGE PAD KITS

Fits between trunk lid hinges and body

48-7042707	6 Pieces	35-36	6.00 kit
78-7042707-A	Humpback, 4 pieces	1937	10.00 kit
78-7042707-B	Flatback, 4 pieces	1937	10.00 kit
78-7442707-C	Phaeton & conv sedan, 4 pieces	37-38	10.00 kit



48-7042707



78-7042707-B

TRUNK HANDLE & BASE KITS-COMLETE 1940-1948

We offer these complete kits which include everything including handle, base, bulb, wiring, pad, and hardware.

- 01A-7043500-K Includes 01A-7043500 handle, 99A-13553 inner base, 99A-13550 outer chrome base, 01A-13556-S lamp, socket, lens & gasket kit 99A-13572 rubber base pad..... 1940 128.50 ea
- 51A-7043511-K Kit includes 11A-7043511 handle 11A-13550 chrome base, 01A-13556-S lamp, socket, lens & gasket kit 11A-13572 rubber base pad.....41-48 240.00 ea



01A-7043500-K



51A-7043511-K

TRUNK HANDLE & BASE PARTS 1939-1948

- 01A-13556-S Lens socket & mounting kit, 8 pieces, by Vintique40-48 19.50 kit
- 01A-13568/9 Gaskets only from above kit40-48 2.00 kit
- 99A-13564 Replacement lens only, 1940-1948 Ford, 1939-1940 Mercury40-48 6.00 ea
- 99A-13553 Inner base, also 1939 Mercury, die cast39-40 12.00 ea
- 01A-7043500 Trunk handle with base (99A-13550), includes 2 keys 1940 65.00 ea
- 99A-13550 Trunk handle base, also 1939 Mercury, chrome, by Vintique... 1940 25.00 ea

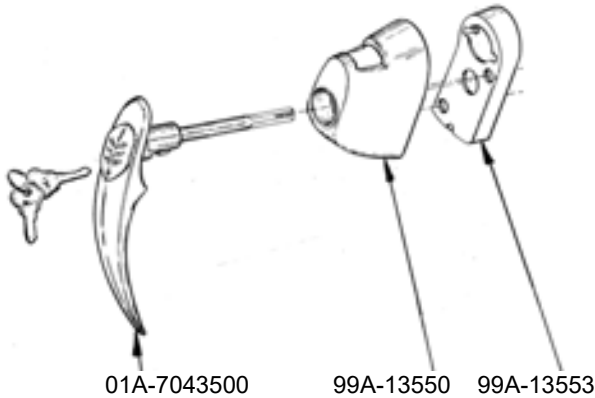

01A-7043500

99A-13550

99A-13553



01A-13556-S Kit



99A-13564

- 11A-7043511 Trunk handle, chrome, includes 2 keys and nut, by Vintique41-48 65.00 ea
- 11A-13550 Trunk handle base, chrome, by Vintique.....41-48 30.00 ea

TRUNK HANDLE & BASE PARTS 1939-1948 continued

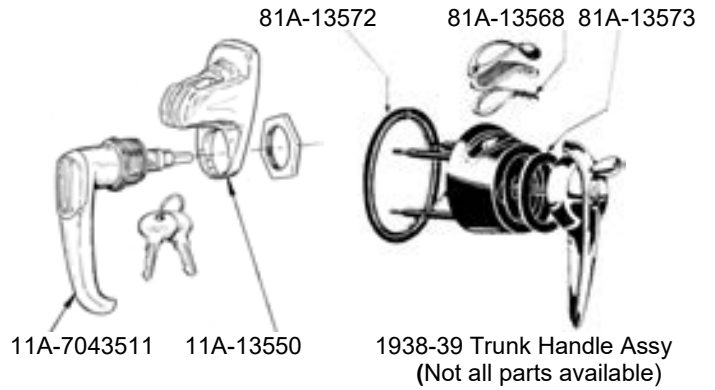

11A-7043511

11A-13550

1938-39 Trunk Handle Assy (Not all parts available)

TRUNK HANDLE & BASE PADS

- A-702356-E Handle pad, rubber 32-37 1.50 ea
- 81A-13568 Handle base lens seal..... 38-39 1.50 ea
- 81A-13572 Base pad, rubber, open type.... 38-39 6.50 ea
- 81A-13572-OR Base pad, rubber, original type 38-39 15.00 ea
- 99A-13572 Base pad, rubber, 1940 Ford and 1939 Mercury 39-40 5.00 ea
- 11A-13572 Base pad, rubber 41-48 5.00 ea

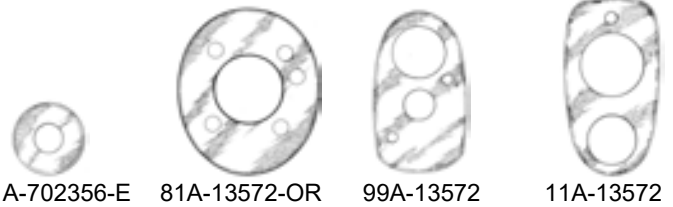

A-702356-E

81A-13572-OR

99A-13572

11A-13572

- 21A-13572 Base pad, rubber, super deluxe 1942 21.00 ea
- 09A-13572 Base pad, rubber, Mercury..... 1940 21.00 ea
- 19A-13572 Base pad, rubber, Mercury..... 1941 14.00 ea
- 29A-13572 Base pad, rubber, Mercury..... 42-48 14.00 ea
- 81A-13573 Handle to base seal 38-39 2.00 ea
- 01A-13557 Shaft seal, sponge rubber 1940 2.00 ea



21A-13572



81A-13573



01A-13557

TRUNK LID EMBLEMS

- 01A-7043370-A Standard, painted blue, die cast chrome, includes pad 1940 N/A
- 01A-7043370-B Deluxe, painted red, die cast chrome, includes pad 1940 N/A
- 01A-7043370 All chrome 1940 N/A
- 01A-7043370-RP Emblem pad, molded rubber with small bead edge 1940 6.50 ea



01A-7043370

01A-7043370-RP

TRUNK ARM & SPRING SUPPORTS

91A-7744200/1	1939-1940 coupes & 1940 Convertible by Drake.....	39-40	140.00 pr
99A-7044200/1	1939-1940 Mercury sedans & 1941-1948 Ford & Mercury Sedans, by Drake.....	39-40	140.00 pr
11A-7744200/1	Coupe & convertible, by Drake.	41-48	140.00 pr

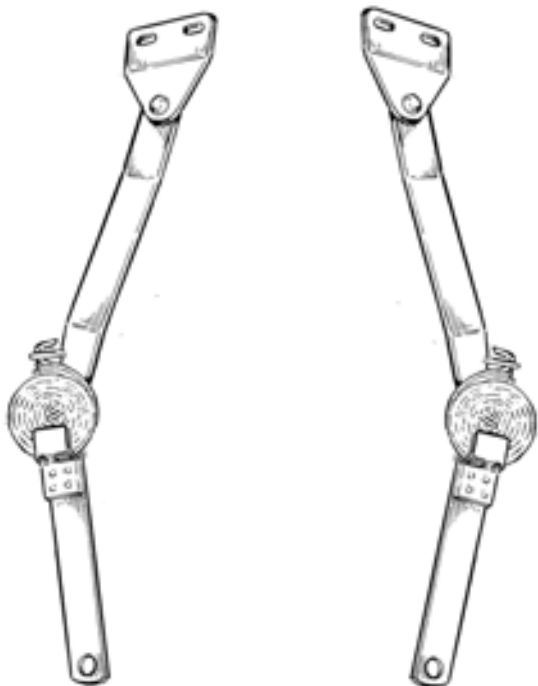

91A-7744236-S Replacement spring only, all styles39-48 12.00 ea



91A-7744236-S

91A-7744200-HK Trunk lid arm hardware kit39-40 15.00 kit



91A-7744200-HK

11A-7744200-HK Trunk lid arm hardware kit41-48 15.00 kit



11A-7744200-HK

TRUNK AND RUMBLE SEALS

Listed below are seals manufactured from extruded neoprene rubber. Adhesive sold separately listed below.

B-7043720	Coupe, roadster & cabriolet, fits rumble or trunk	32-34	15.00 set
48-7043720-A	Coupe, trunk only, 2 pieces.....	35-36	35.00 set
48-7043720-B	Coupe, roadster & cabriolet, rumble lid only, 2 pieces	35-39	30.00 set



B-7043720

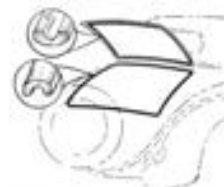

48-7043720-A



48-7043720-B

48-706860	Tudor & Fordor, "humpback" sedans	35-36	30.00 ea
78-713540	All bodies styles except Phaeton & convertible sedan hollow core.....	37-48	30.00 ea
78-7443720	Phaeton & convertible sedan ...	37-48	30.00 ea

TRUNK SEALS-BONDED CORNERS

Same extruded neoprene sponge rubber seals as above except for bonded corners.

91A-7043720	Tudor & Fordor, 1938 Deluxe & 1939-1940 all Tudor & Fordor..	38-40	50.00 ea
91A-7243720	Coupe	39-40	50.00 ea
01A-7643720	Convertible.....	1940	50.00 ea
11A-7643720	Convertible.....	41-48	50.00 ea
11A-7243720	Coupe	41-48	50.00 ea
11A-7043720	Tudor & Fordor.....	41-48	50.00 ea



Bonded corners

TRUNK SEAL CLIP KIT

Helps to secure seal in corners.

11A-7244817-HK	Includes 2 clips & hardware, Coupe and convertible	41-48	6.00 kit
----------------	--	-------	----------

WEATHERSTRIP ADHESIVE

Black color, use for door seals, trunk seals, etc.

M-500	5.0 ounce tube.....	10.00 ea
-------	---------------------	----------



STATION WAGON TAILGATE & WINDOW SEALS

78-796130-K	Upper & lower tailgate seals ...	37-39	125.00 kit
01A-7942086-K	Upper & lower tailgate seals	1940	75.00 kit
11A-7942086-K	Upper & lower tailgate seals	41-48	60.00 kit
11A-7941936-K	Back window weather seal, surrounds glass, not included in above kit.....	41-48	35.00 kit

WIPER ARMS - ORIGINAL & WRIST TYPE *

STAINLESS STEEL ARMS & CHROME SHAFT MOUNTS

B-17529 All bodies uses original style blade 32-36 8.00 ea



1937-1939 Closed car and pickup

78-17529 Use with original style blade..... 37-39 15.00 ea

78-17529-WT Use with wrist type blade * 37-39 15.00 ea



1937-1940 Convertible, station wagon and 1940 closed car

01A-17529 Use with original style blade..... 37-40 15.00 ea

01A-17529-WT Use with wrist type blade * 37-40 15.00 ea



1940-1947 Pickup

01C-17526 RH use with original style blade 40-47 15.00 ea

01C-17527 LH use with original style blade 40-47 15.00 ea

01C-17526-WT RH use with wrist style blade * 40-47 15.00 ea

01C-17527-WT LH use with wrist style blade * 40-47 15.00 ea

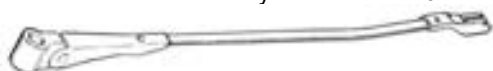

1941-1948 Cars

11A-17526 RH use with original style blade 41-48 15.00 ea

11A-17527 LH use with original style blade 41-48 15.00 ea

11A-17526-WT RH use with wrist style blade * 41-48 15.00 ea

11A-17527-WT LH use with wrist style blade * 41-48 15.00 ea



*** Wrist type blades (listed below) feature a more modern & improved wiping design. (Original type blade mounts ends are shown)**

1948-1952 Pickup R.H. or L.H

7C-17527 Use with wrist type blade. 48-52 15.00 ea

WIPER ARMS & BLADES (UNIVERSAL)

Use with wrist type blade, clamps on 1/4" shaft

WT-17529-SS Wiper arm, extends from 8" to 12"..... 13.00 ea

WT-17529- Wiper arm for chopped windshields,

CHP extends from 6" to 8" 13.00 ea



WIPER BLADES - ORIGINAL STYLE

B-17528 7-1/2" long..... 28-40 4.00 ea

68-17528 8-1/4" long..... 28-40 4.00 ea

51A-17528 9" long..... 41-48 4.00 ea

C-17528 10" long..... 4.00 ea



WIPER BLADES - WRIST TYPE

SR-17528 Deluxe wiper blade, 6" long..... 15.00 ea

78-17528 Deluxe wiper blade, 8-1/4" long 37-40 15.00 ea

7C-17528 Deluxe wiper blade, 10" long..... 41-48 15.00 ea



TANDEM WIPER ARM ASSEMBLY

68-17574 Includes 2 wiper arms, 2 blades, swivel post & connecting shaft, fits all body styles 28-36 30.00 set

HAND WIPER ASSEMBLY

A-17655-AR Chrome plated with rubber blade..... 25.00 ea

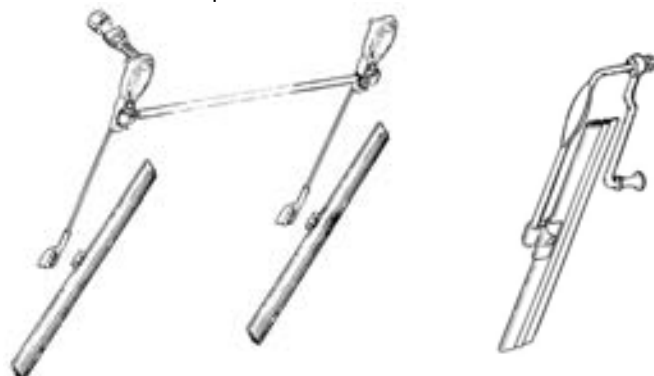

68-17574 Tandem wiper arm assembly

A-17655-AR Hand wiper assembly

WIPER MOTOR NUT, SHAFT SEALS & PARTS

78-17481 Wiper arm nut, chrome, holds arm to tower, 1937-40 cars and 1937-47 pickup 37-47 3.00 ea

40-17512-B Wiper shaft nut, 5/16-32 thread closed car & pickup 30-36 2.50 ea

40-17541 Seal, closed car 32-34 3.00 ea

48-17541 Seal, closed car 35-36 3.00 ea

11A-17541 Seal, small, 1937-1939 closed car, 1940-1947 pickup and 1941-1946 closed car 37-48 3.00 pr

7C-17541 Seal, large, 41-48 cars & 48-52 pickup 41-48 3.00 pr

78-17515 Wiper pivot bezel, chrome, closed cars 37-39 9.00 ea

01C-17515 Wiper pivot bezel, chrome, pickup 40-47 ASK

11A-17515 Wiper pivot bezel chrome, cars * 41-46 18.00 pr

7C-17515 Wiper pivot bezel, chrome, 42-48 cars * 42-48 12.00 ea

356094-S Wiper pivot nut, chrome 47-48 5.00 ea

78-17512 Wiper attaching nut, 1937-1938 closed cars, 1938-1947 pickups..... 37-47 2.00 ea

***Ford installed either a large or small bezel on the 1941-1948 passenger cars, check the illustration below for your type.**

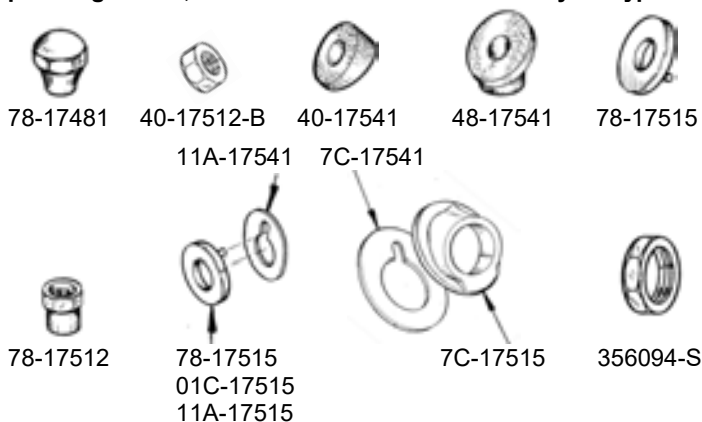

1937-1940 CAR & 1937-1947 PICKUP WIPER DESIGN

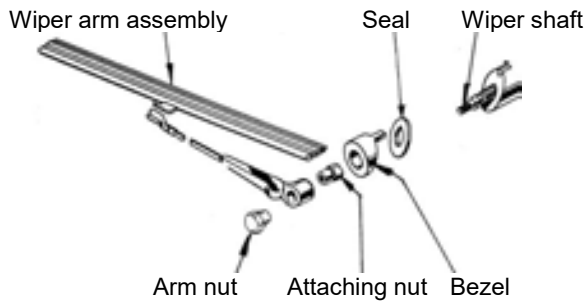

VACUUM LINE, HOSE & TUBE NUT

B-17517-D	Stanchion vacuum line, roadster & phaeton, 9 1/2' long ..	1932	7.75ea
A-17520	Vacuum wiper hose, 6 foot length.....	28-55	8.00 pc
B-17542	Wiper tube to manifold nut, .19 diameter tube	32-38	1.50 ea
91A-17542	Wiper tube to manifold nut, .28 diameter tube	39-40	2.00 ea



WIPER RODS & GROMMETS

78-17537	Wiper rod & rubber grommet, switch to motor, convertible and wagon.....	37-39	10.00 ea
01A-17537	Wiper rod & rubber grommet, switch to motor, passenger.....	1940	ASK
01A-17537-G	Rubber grommet only, passenger.....	37-40	1.50 ea



WIPER TOWERS

Each kit includes: Right and left hand tower assemblies, chrome bases or bezels, pivot arms with both long and short connecting arms and the clamp brackets with mounting hardware. Sold as a complete kit.

78-17552/3	Convertible & station wagon.....	37-39	125.00 kit
01A-17552/3-C	Convertible & station wagon.....	1940	ASK
01A-17552/3-D	1940 closed car & 1941 sedan delivery	40-41	ASK
51A-17500	1946 (late) & 1947-48 cars	46-48	175.00 kit



WIPER TOWER PADS

Molded rubber

78-17556	Convertible & station wagon.....	37-40	4.00 pr
01A-17556	1940 closed car & 1941 sedan delivery	40-41	4.00 pr

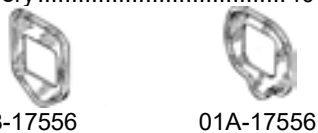

WIPER ARM PARTS

78-17450	Clip & spring assembly, holds arm to motor.....	37-48	2.50 ea
11A-17450	Clip & spring assembly, holds arm to motor.....	41-48	2.50 ea

PLEASE CHECK DIMENSIONS BELOW BEFORE ORDERING

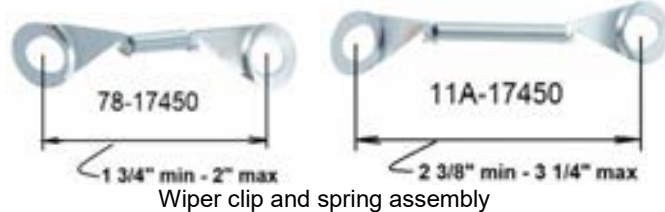

WIPER ARM TO MOTOR GROMMET

51A-17562	Wiper arm to motor rubber grommet.....	46-48	2.00 ea
-----------	--	-------	---------



VACUUM WIPER MOTOR GASKETS

A-17508-G	Wiper motor bowl gaskets only from kit above.....	28-40	4.50 pr
-----------	---	-------	---------



A-17508-G

VACUUM WIPER LINE

40-17538	Runs from intake to dash, copper clad steel includes fittings	33-36	15.00 ea
----------	---	-------	----------



1940-48 CAR ELECTRIC WIPER MOTOR CONVERSION KITS

Designed to bolt in place of the stock vacuum wiper motors.

01A-17508-HD12	Passenger, 12 Volt	1940	165.00 kit
01A-17508-HD6	Passenger, 6 Volt	1940	165.00 kit
11A-17508-HD12	Passenger, 12 Volt	41-42	165.00 kit
11A-17508-HD6	Passenger, 6 Volt	41-42	165.00 kit
51A-17508-HD12	Passenger, 12 Volt	46-48	165.00 kit
51A-17508-HD6	Passenger, 6 Volt	46-48	165.00 kit

The motor is a heavy duty 12 volt or 6 volt, 2 speed unit with automatic park. Each kit comes with all mounting brackets, dash mount switch, fuse, and instructions. May not work on 1941-42 cars with original radios with built in speaker, please contact before ordering.

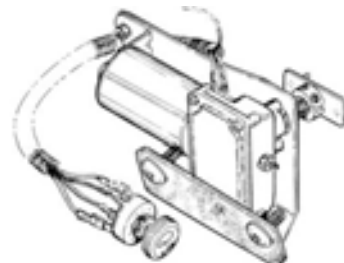

01A-17508-HD12

1932-1936 CAR & 1932-1947 PICKUP ELECTRIC

WIPER MOTOR-COMPACT SIZE

Similar in size to original vacuum motor. Includes wiper arm, wiper blade, washer & material to make bezel. Black housing. Requires ON-OFF switch. Can be used for 1932-36 Cars & 1932-1947 Pickups.

- B-17508-MT-6 6 volt, includes wiper arm with mounting nut & 8 1/4" original style blade 68-17528..... 170.00 kit
 - B-17508-MT-12 As above except 12 volt..... 160.00 kit
 - B-17508-MT-6-D 6 volt, includes wiper arm with mounting nut & 8 1/4" wrist style blade 78-17528-WT..... 180.00 kit
 - B-17508-MT-12-D As above except 12 volt..... 170.00 kit
 - B-17508-SW Push-pull switch for above motors 8.00 ea
- Wrist type blades lock onto arms better than original style. Will not operate tandem wiper set.



B-17508-MT

B-17508-SW

REPLACEMENT ELECTRIC WIPER MOTOR

With black housing & built in ON-OFF switch. Requires wiper arm & blade. Larger in size than above compact motors & does not fit behind 1933-1936 header panels.

- A-17508-E6 6 Volt..... 40.00 ea
- A-17508-E12 12 Volt..... 40.00 ea

This motor is machined to accept stock wiper arm part B-17529 or updated universal wiper arm part WT-17529. The shaft is 3-1/4" long and includes instructions for shortening the shaft to 2-1/2". This self parking wiper motor has a 110 degree sweep.

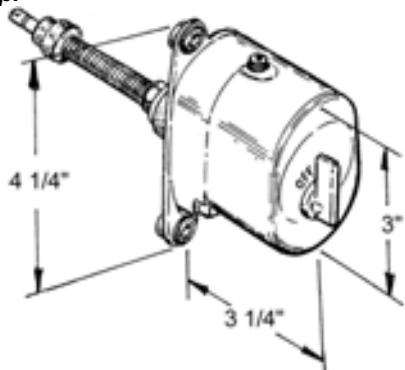

Dimensional for A-17508 electric motors listed above & below

REPLACEMENT ELECTRIC WIPER MOTOR

With stainless steel housing, requires ON-OFF switch, wiper arm & blade.

- A-17508-SS6MO 6 Volt..... 45.00 ea
- A-17508-SS12MO 12 Volt..... 45.00 ea

The shaft is 5" long to fit most applications, and includes instructions for shortening the shaft for any particular installation. Other basic dimensions same as above motor shown (less ON-OFF switch.) Includes wiring diagram. Use this self parking motor with any of the universal wiper arms & blades, part WT-17529.

WIPER KNOBS

- B-17513 Chrome, 1932-1936 all styles and 1937 closed car, screw on..... 32-37 2.50 ea
- 78-17513-A Light brown, standard, push on..... 1937 6.00 ea
- 78-17513-B Yellow brown, deluxe, push on..... 1937 6.00 ea
- 81A-17513-A Ivory, closed car, screw on..... 1938 6.00 ea
- 81A-17513-B Ivory, open car & station wagon push on..... 1938 6.00 ea
- 91A-17513-A Light yellow, closed car, screw on..... 1939 6.00 ea
- 91A-17513-B Light yellow, open car and station wagon, push on..... 1939 6.00 ea
- 01A-17513-A Sand, standard & 1940-1941 pickup, push on..... 1940 6.00 ea
- 01A-17513-B Maroon, deluxe, push on..... 1940 6.00 ea
- 11A-17513 Light tan, all styles, push on..... 1941 7.00 ea
- 21A-17513-A Maroon, standard, push on..... 1942 10.00 ea
- 21A-17513-B Butterscotch, deluxe & super deluxe, push on..... 1942 10.00 ea
- 21C-17513 Black, pickup, push on..... 42-47 8.00 ea
- 51A-17513-A Chocolate brown, deluxe, push on..... 1946 ASK
- 51A-17513-B Metallic blue gray, super deluxe, push on..... 1946 8.00 ea
- 51A-17513-C Gray-tan, all styles, push on..... 47-48 8.00 ea

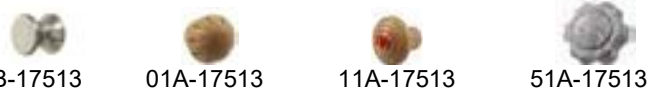

B-17513

01A-17513

11A-17513

51A-17513

WIPER CONTROL ASSEMBLIES

- 78-17535 Light brown, standard 1937 40.00 ea
- 81A-17535 Ivory, all styles 1938 40.00 ea
- 91A-17535 Light yellow, open car & wagon 1939 40.00 ea



78-17535

81A-17535

91A-17535

- 01A-17535-A Sand, standard..... 1940 35.00 ea
- 01A-17535-B Maroon, deluxe 1940 35.00 ea
- 01C-17535 Sand, pickup 40-41 35.00 ea



01A-17535

01C-17535

- 21C-17535 Black, pickup..... 42-47 35.00 ea
- 51A-17535-B Blue-gray, super deluxe * 1946 25.00 ea
- 51A-17535-C Gray-tan, 1946 club convertible, wagon & sportsman and 1947-1948 all styles * 46-48 25.00 ea

* Not a vacuum switch

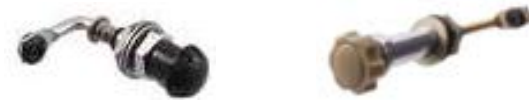

21C-17535

51A-17513

INSIDE REAR VIEW MIRRORS

NON-ORIGINAL STYLE- STAINLESS STEEL

Complete with glass & mounting bracket

B-17681-SR	Open car.....	1932	45.00 ea
B-17682-SR	Closed car	32-36	45.00 ea
B-17690-SR	Cabriolet.....	32-34	55.00 ea



B-17681-SR



B-17682-SR



B-17690-SR

40-17681-SR	Open car.....	33-34	45.00 ea
48-17690-SR	Cabriolet.....	35-36	55.00 ea
68-17682-SC	1935 late and 36 closed car	35-36	48.00 ea



40-17681-SR



48-17690-SR



68-17682-SC

78-17681-SS	Convertible	37-48	55.00 ea
78-17682-SS	Closed car	37-39	55.00 ea
01A-17682-SS	Closed car	1940	55.00 ea



78-17681-SS



78-17682-SS



01A-17682-SS

INSIDE REAR VIEW MIRRORS

ORIGINAL STYLE

Complete with glass & mounting bracket

B-17681-SS	Roadster & phaeton, stainless steel	1932	35.00 ea
B-17682	Closed car & pickup, painted brown	32-36	48.00 ea
B-17682-SS	Closed car & pickup, same as B-17682 except stainless steel	32-36	35.00 ea
B-17690-SS	Cabriolet & convertible sedan, stainless steel	32-34	40.00 ea



B-17681-SS



B-17682



B-17690-SS

INSIDE REAR VIEW MIRRORS-continued

ORIGINAL STYLE

Complete with glass & mounting bracket

40-17681-SS	Roadster & phaeton, stainless steel	33-36	35.00 ea
48-17690-SS	Cabriolet & convertible sedan, stainless steel	35-36	40.00 ea



40-17681-SS



48-17690-SS

68-17682	1935 late & 1936 closed car, painted brown	35-36	ASK
78-17681	Convertible & station wagon, painted brown	37-39	ASK



68-17682



78-17681

11A-17682-SS	1941-1948 closed car and 1942-1952 pickup, stainless Steel, stock style mirror head...	40-52	42.00 ea
11A-17682-SR	Similar to 11A-17682-SS except with oval mirror head ..	40-52	45.00 ea



11A-17682-SS



11A-17682-SR

INSIDE MIRROR HEAD ONLY

B-17680-G	Original rectangular shape 2 5/8" x 5" with beveled edges, fits all bodies.....	32-36	7.50 ea
B-17681-SG	Similar to above mirror except 2 5/8" X 6" with stainless rim and back.....	32-36	20.00 ea
68-17682-MHSS	Original oval shape, polished stainless teel back, for 1935-1936 some models, 1937-1940 cars and 1935-1947 pickups	35-47	25.00 ea



B-17680-G



B-17681-SG



68-17682-MHSS

DOOR HINGE PIN MIRRORS

Mirror heads stainless steel - 4" diameter. Arms are chrome plated and fit left hand or right hand. Hinge pins are included. Bob Drake mirrors require the installation of a tapped hole in hinge (as original) to secure other brand uses set screws.

B-17741	Closed car, except 3-window, chrome arm, 2" hinge height		
	By Vintique.....	1932	50.00 ea
	By Bob Drake.....	1932	ASK
46-17741	Pickup, chrome arm, 2" hinge height		
	By Vintique.....	32-34	ASK
	By Bob Drake.....	32-34	50.00 ea

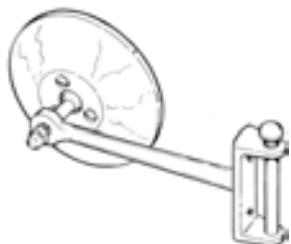

B-17741 & 46-17741

50-17741-C	Pickup, chrome, straight arm, 2" hinge height	35-47	50.00 ea
50-17741-B	Pickup, black, straight arm, 2" hinge height	35-47	ASK
48-18403-E	1935 passenger & 1948-1952 pickup, chrome, straight arm, 2 1/4" hinge height		
	By Bob Drake.....	35-52	58.00 ea



50-17741 & 48-18403-E

48-18403	1936-1940 passenger *, chrome, curved arm, 2 1/4" hinge height		
	By Dennis Carpenter.....	36-40	40.00 ea
	By Bob Drake.....	36-40	40.00 ea

*Also fits 1935 passenger and 1948-1952 pickup.

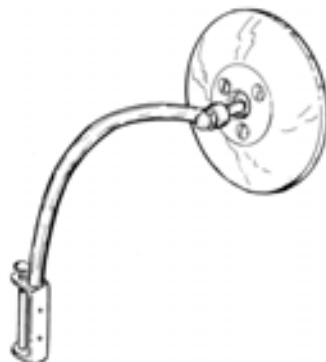

48-18403

REPLACEMENT MIRROR HEADS

B-17741-MH	Mirror head only, 4" stainless steel 1935-1940 cars and 1935-1952 pickup	35-52	20.00 ea
CNX-17741-MH	Mirror head 4" as above except with convex mirror for wider range of visibility	32-52	20.00 ea
A-17741-MHC	Mirror head only, 5" diameter chrome	28-56	10.00 ea
A-17741-MHB	Mirror head only, 5" diameter black	28-56	10.00 ea



B-17741-MH (4")



CNX-17741-MH (4")



A-17741-MHC (5")



A-17741-MHB (5")

HINGE PIN PULLER

Made of forged steel with a heat treated bolt, stainless steel extensions included.

TL-100	Hinge pin puller with Extension pins	25.00 ea
TL-100-P	Spare set of extension pins for puller	5.00 ea

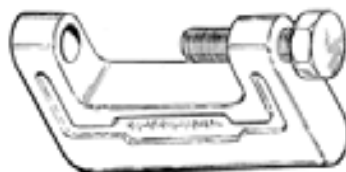

Hinge pin puller



Extension pins

POST MIRRORS

All polished stainless steel, with fully adjustable mirror head.

18-17700-P	Open car, stainless steel shaft.....	1932	40.00 ea
B-17741-MH	Mirror head only, for current post mirrors	1932	20.00 ea
A-17700-MH	Replacement post mirror head for old style post mirror	1932	18.00 ea
18-17700-CHP	Open car post mirror, arm is chopped 2"	1932	40.00 ea



CURVED ARM PEEP MIRRORS

3" or 4" diameter mirror.

Excellent quality mirrors fit most cars with a door edge. These stainless steel mirror heads are fully adjustable to fit many mounting angles. Rubber mounting pad & set screw wrench included. Polished stainless steel mounting bracket and head.

- HR-18414-L LH, 3" diameter mirror, FLAT glass22.00 ea
- HR-18414-R RH, 3" diameter mirror, FLAT glass.....22.00 ea
- B-18414-L LH, 4" diameter mirror, FLAT glass22.00 ea
- B-18414-R RH, 4" diameter mirror, FLAT glass.....22.00 ea
- CNX-18414-L/R 4" mirror with CONVEX glass,
sold in pairs only, RH & LH *60.00 pr



CNX-18414

*** NOTE: CONVEX MIRRORS LISTED HAVE GLASS WITH SLIGHT CONVEX FOR WIDER RANGE VISIBILITY. AVAILABLE ONLY IN CURVED & STRAIGHT ARM PEEP MIRRORS**

CURVED ARM "RETRO STYLE" MIRROR

SR-18402/3-S Round head, pairs\$75.00 pr

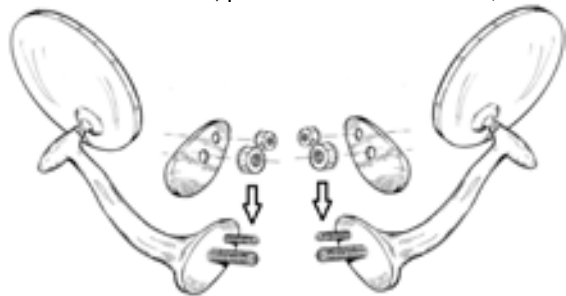

SR-18402/3-S

WIND WING MIRRORS

Clamps on the edge of wind glass with two rubber padded clamping arms.

B-17700-WWSS Polished stainless steel, fits all years with wind wings.....25.00 ea



STRAIGHT ARM PEEP MIRRORS

Excellent quality mirrors fit most cars with a door edge. Stainless steel mirror heads are fully adjustable to fit many mounting angles. Rubber mounting pad & allen wrench included. Arm is 5 1/4" long.

- A-17741-UP 4" mirror with FLAT glass
fits LH and RH..... 20.00 ea
- CNX-17741-U 4" mirror with CONVEX glass, fits
LH & RH *ASK



A-17741-UP



CNX-17741-U

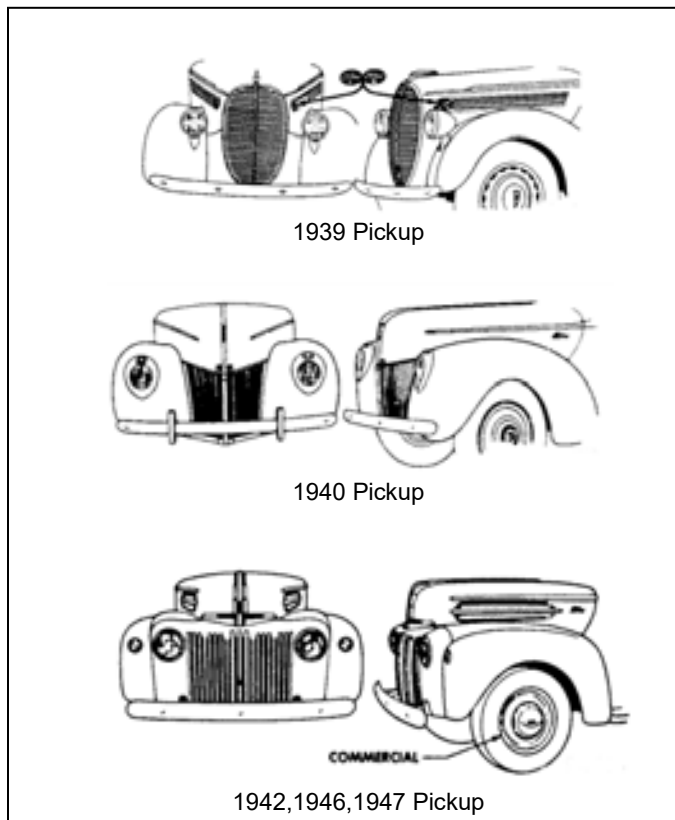

1939 Pickup

1940 Pickup

1942, 1946, 1947 Pickup

FRONT HOOD TRIM, 1939, 1940, 1941

- 91A-8264/5-S Lower hood trim, deluxe, chrome 1939 ASK
- 91A-8266/7 "Cat whiskers" trim, deluxe, chrome 1939 75.00 pr

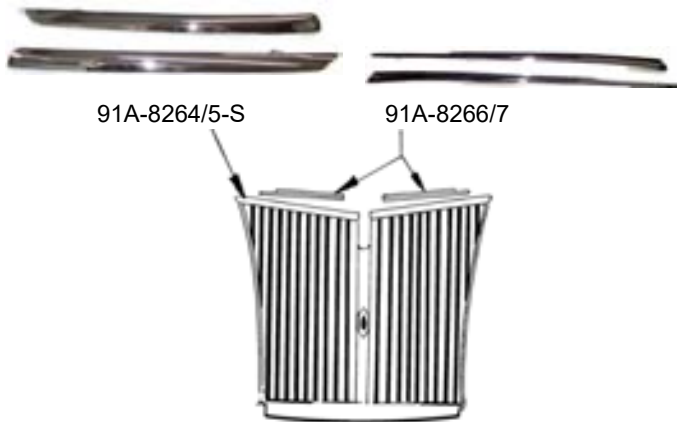

- 01A-8216 Hood trim, front lip of hood, 1940 standard & 1940-1941 pickup, stainless steel40-41 70.00 pr



- 01A-16868/9 Lower hood "Big trim", top of middle section, deluxe 1940 95.00 pr
- 01A-16954/5 Lower hood "Small trim", deluxe .. 1940 ASK

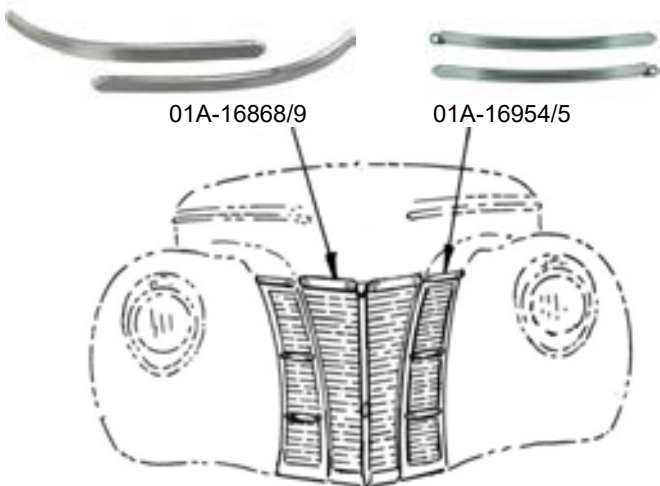

- 11C-8264/5-S Lower hood trim, pickup, chrome 1941 175.00 pr



11C-8264/5-S

HOOD MOLDINGS 1935,1936 - STAINLESS STEEL

- 48-16722-S Side molding, 8 pieces* 1935 125.00 set
 - 68-16722-S Side molding, 6 pieces* 1936 125.00 set
- *Includes mounting clips

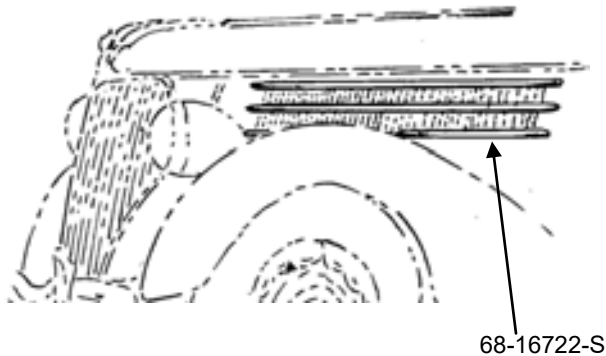

BODY MOLDINGS

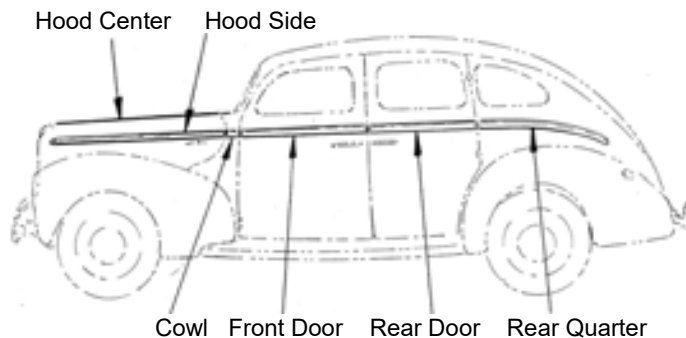

HOOD MOLDINGS 1939 DELUXE - STAINLESS STEEL

- 91A-16722-B Side upper molding, RH 1939 65.00 ea
- 91A-16723-B Side upper molding, LH 1939 65.00 ea
- 91A-16724-B Side lower molding, LH or RH 1939 35.00 ea
- 91A-16736 Center strip 1939 39.00 ea

HOOD MOLDINGS 1940,1941 - STAINLESS STEEL

- 01A-16722-A Side molding, RH, standard 1940 50.00 ea
- 01A-16723-A Side molding, LH, standard 1940 50.00 ea
- 01A-16722-B Side molding, RH, deluxe 1940 50.00 ea
- 01A-16723-B Side molding, LH, deluxe 1940 50.00 ea
- 01A-16736-A Center strip, standard, also 1941 delivery 1940 39.00 ea
- 01A-16736-B Center strip, deluxe 1940 55.00 ea
- 01C-16736 Center strip, pickup 40-41 39.00 ea

HOOD MOLDINGS 1942,1948 -STAINLESS STEEL

- 21C-16736 Center strip, pickup, commercial . 42-47 55.00 ea
- 6A-16722/3-B Side molding, passenger, RH and LH 47-48 150.00 pr

COWL MOLDINGS - STAINLESS STEEL

- 91A-700328/9 Passenger 1939 45.00 pr
- 01A-700328/9 Passenger 1940 40.00 pr
- 6A-7002328/9-B Passenger 47-48 80.00 pr

SEE THE FOLLOWING PAGES FOR CLIPS TO INSTALL MOLDINGS

FRONT DOOR MOLDINGS – STAINLESS STEEL

91A-7020934	Tudor, RH.....	1939	60.00	ea
91A-7020935	Tudor, LH.....	1939	60.00	ea
91A-7320934	Fordor, coupe & sedan delivery, RH.....	1939	60.00	ea
91A-7320935	Fordor, coupe & sedan delivery, LH.....	1939	60.00	ea
91A-7720934	Convertible, RH.....	1939	45.00	ea
91A-7720935	Convertible, LH.....	1939	45.00	ea
91A-7420934	Convertible 4 door sedan, RH..	1939	ASK	
91A-7420935	Convertible 4 door sedan, LH...	1939	40.00	ea
01A-7020934	Tudor & convertible, RH.....	1940	40.00	ea
01A-7020935	Tudor & convertible, LH.....	1940	40.00	ea
01A-7320934	Coupe & fordor, RH.....	1940	40.00	ea
01A-7320935	Coupe & fordor, LH.....	1940	40.00	ea
6A-7020934/5-B	Sedan coupe, Tudor & Conv. LONG DOOR, RH & LH *.....	47-48	150.00	pr
6A-7320934/5-B	Business coupe, fordor & sedan del'y SHORT DOOR, RH & LH *.....	47-48	150.00	pr

*Ford made 2 type of coupes, a sedan coupe (long door) with back seat & business coupe with no back seat (short door)

REAR DOOR MOLDINGS - STAINLESS STEEL

91A-7325554	Fordor, RH.....	1939	35.00	ea
91A-7325555	Fordor, LH.....	1939	35.00	ea
91A-7425554	Convertible, RH.....	1939	40.00	ea
91A-7425555	Convertible, LH.....	1939	40.00	ea
01A-7325555	Fordor, RH or LH.....	1940	55.00	ea

REAR QUARTER MOLDINGS - STAINLESS STEEL

91A-7029034	Tudor, RH.....	1939	115.00	ea
91A-7029035	Tudor, LH.....	1939	115.00	ea
91A-7329034	Fordor, RH.....	1939	60.00	ea
91A-7329035	Fordor, LH.....	1939	60.00	ea
91A-7629034	Convertible, RH.....	1939	125.00	ea
91A-7629035	Convertible, LH.....	1939	125.00	ea
91A-7429034	Convertible 4 door sedan, RH..	1939	75.00	ea
91A-7429035	Convertible 4 door sedan, LH...	1939	75.00	ea
91A-7729034	Coupe, RH.....	1939	95.00	ea
91A-7729035	Coupe, LH.....	1939	95.00	ea
91A-7829034	Sedan delivery, RH or LH.....	1939	60.00	ea
01A-6629044-B	Convertible, RH.....	1940	60.00	ea
01A-6629045-B	Convertible, LH.....	1940	60.00	ea
01A-7029034	Tudor, RH.....	1940	60.00	ea
01A-7029035	Tudor, LH.....	1940	60.00	ea
01A-7329034	Fordor, RH.....	1940	70.00	ea
01A-7329035	Fordor, LH.....	1940	70.00	ea
01A-7729034	Coupe, RH.....	1940	65.00	ea
01A-7729035	Coupe, LH.....	1940	65.00	ea
01A-7829034	Sedan Delivery, RH or LH.....	1940	55.00	ea
6A-7029034/5-B	Tudor, LH and RH.....	47-48	190.00	pr
6A-7629034/5-B	Sedan coupe & convertible, LH and RH.....	47-48	190.00	pr

RUNNING BOARD TRIM

48-16462-S	Passenger, stainless steel.....	35-36	95.00	pr
78-16462-S	1937-1938 passenger & 1939 standard, stainless steel.....	37-39	95.00	pr
6A-16466/7	Passenger, stainless steel, will also fit 1942-1946 passenger, although original was ribbed.....	47-48	95.00	pr



FRONT FENDER MOLDINGS

68-16000	Between front fender & horn apron, stainless steel, 4 pcs.....	1936	40.00	set
----------	---	------	-------	-----

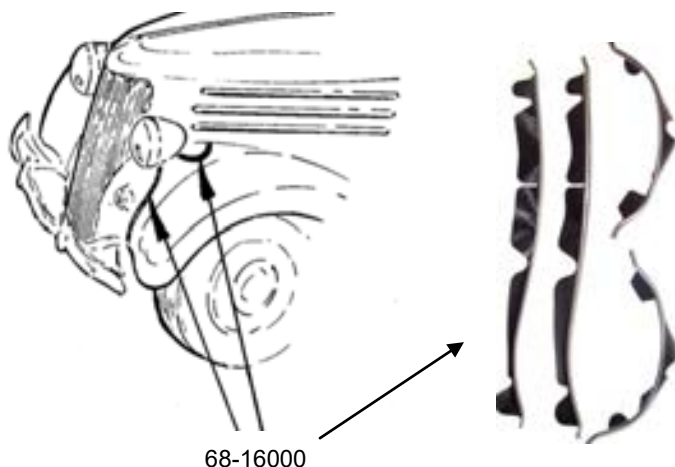

6A-16003	Upper right front, stainless steel.....	47-48	95.00	ea
6A-16004	Upper left front, stainless steel.....	47-48	95.00	ea
6A-16168/9	Lower front, bright metal.....	47-48	60.00	pr

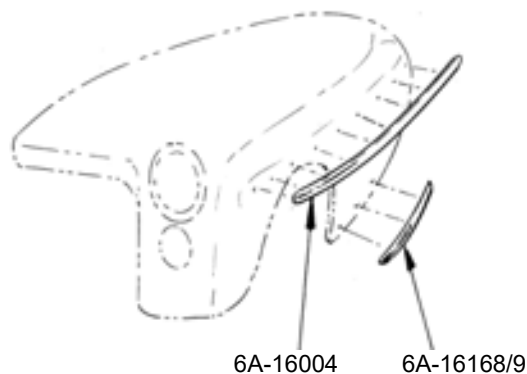

REAR FENDER MOLDINGS

6A-16196-A	Right side, stainless steel, not for sportsman, sedan delivery or station wagon.....	47-48	135.00	ea
6A-16197-A	Left side, stainless steel, not for sportsman, sedan delivery or station wagon.....	47-48	135.00	ea



TRIM CLIPS 1934-1936

40-20001	Radiator grille trim clips, 1934 cars & 1935 pickup, set of 12.....	34-35	5.00	set
48-20001	Radiator grille trim clips, cars, set of 34.....	1935	10.00	set
48-20004	Hood clips trim clip set, cars, set of 32.....	1935	10.00	set
48-20000	Trim clip kit, cars includes 48-20001 & 48-20004.....	1935	18.00	kit
68-20001	Center grille strip clips, cars set of 6.....	1936	4.00	set
68-20002	Outer grille strip clips, 1936 cars & 1935-36 pickup, set of 16.....	35-36	5.50	set
68-20004	Side of hood clips, cars, set of 24.....	1936	7.50	set
68-20000	Trim clip kit, cars, includes 68-20001, 68-20002, 68-20004.....	1936	17.00	kit

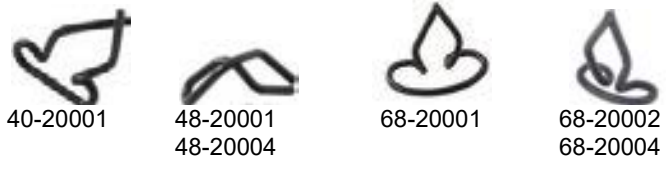

TRIM CLIPS 1937

78-16720/1-CP	Outer grille & hood side, set of 25, 2 sets per car	1937	20.00	set
91A-20020-B	Interior upper door window trim panel clips. Set of 6. 3 kits does 2 doors.	1937	4.00	set



78-16720/1-CP

TRIM CLIPS 1938 Standard cars

81A-20001	Grille & hood side clips, set of 56.....	1938	11.00	set
81A-20004-A	Grille side & hood side clips set of 12.....	1938	5.00	set
81A-20005	Body belt, set of 58.....	38-39	14.00	set
81A-20006	Body belt bolts, set of 14	38-39	8.00	set
81A-20000-A	Trim clip kit includes 81A-20001 81A-20004, 81A-20005 & 81A-20006.....	1938	38.00	kit

TRIM CLIPS 1938 Deluxe cars

81A-20004-B	Grille side & hood side clips set of 10.....	1938	5.00	set
81A-20005	Body belt, set of 58.....	1938	14.00	set
81A-20006	Body belt bolts, set of 14	1938	8.00	set
81A-20000-B	Trim clip kit includes 81A-20004, 81A-20005 & 81A-20006.....	1938	27.00	kit
91A-20020-B	Interior upper door window trim panel clips. Set of 6. 3 kits does 2 doors.	1939	4.00	set



81A-20001 81A-20004-A
81A-20005
81A-20004-B 81A-20006

TRIM CLIPS 1939 Standard cars

91A-20001-A	Grille bars & hood side louver clips, set of 30	1939	9.00	set
81A-20005	Body belt & hood side clips, set of 58	1939	14.00	set
81A-20006	Body belt bolts, set of 14	1939	8.00	set
91A-20000-A	Standard trim clip kit includes 91A-20001-A, 81A-20005 & 81A-20006	1939	31.00	kit



91A-20001-A 81A-20005 81A-20006

TRIM CLIPS 1939 Deluxe cars

91A-20001-B	Grille bars clips, set of 82.....	1939	16.50	set
91A-20003	Top center of hood clips, set of 8	1939	5.00	set
91A-20004	Side of grille clips, set of 8	1939	4.00	set
91A-20005	Body belt & hood side clips, set of 70	1939	16.00	set
81A-20006	Body belt bolts, set of 14	1939	8.00	set
91A-20000-B	Deluxe trim clip kit includes 91A-20001-B 91A-20003, 91A-20004, 91A-20005 & 81A-20006	1939	49.00	kit
91A-20020-B	Dash chrome clips, set of 6.....	1939	4.00	set
91A-20020-B	Interior upper door window trim panel clips. Set of 6. 3 kits does 2 doors.	1939	4.00	set



91A-20001-B 91A-20003 91A-20004
91A-20005 81A-20006 91A-20020-B

TRIM CLIPS 1940 Standard cars & 1940-41 pickup

91A-20003	Top center of hood clips, set of 8, cars & pickups.....	40-41	5.00	set
01A-20005	Body belt & hood side clips, cars, set of 58	1940	14.00	set
01A-20006	Body belt bolt & nut fasteners cars, set of 8	1940	6.00	set
01A-20000-A	Standard car trim clip kit includes 91A-20003, 01A-20005 & 01A-20006	1940	25.00	kit
91A-20020-B	Interior upper door window trim panel clips. Set of 6. 3 kits does 2 doors.	1939	4.00	set



91A-20003 01A-20005 01A-20006

TRIM CLIPS 1940 Deluxe cars

01A-20001	Grille trim clips, set of 16	1940	6.00 set
01A-20002	Lower front of hood trim fasteners, set of 4 bolts with nuts & 2 clips	1940	5.00 set
91A-20003	Top center of hood clips, set of 8	1940	5.00 set
01A-20005	Body belt & hood side clips, set of 58	1940	14.00 set
01A-20006	Body belt bolt & nut fasteners set of 8	1940	6.00 set
01A-20000-B	Deluxe car trim clip kit includes 01A-20001, 01A-20002, 91A-20003, 01A-20005 & 01A-20006	1940	36.00 kit
91A-20020-B	Interior upper door window trim panel clips. Set of 6. 3 kits does 2 doors.	1939	4.00 set



TRIM CLIPS 1942-1946 Cars

21A-20005	Body belt fasteners, set of 50 clips & 8 bolts with nuts	42-46	20.00 set
21A-20011	Fender, 38 bolts with nuts	42-46	20.00 set
51A-20012	Deck lid, set of 12 clips & 4 bolts with nuts	42-46	6.00 set
21A-20000-A	Convertible trim fasteners kit, includes 21A-20005, 21A-20011 & 51A-20012	42-46	46.00 kit
21A-20000-B	2 door closed car trim fastener kit includes 21A-20005, 21A-20011, 51A-20012, 11A-20007 & 11A-20008	42-46	65.00 kit
21A-20000-C	Fordor trim fastener kit includes 21A-20005, 21A-20011, 51A-20012, 11A-20009 & 11A-20010	42-46	73.00 kit



TRIM CLIPS 1941 Cars

11A-20005	Body belt fasteners, set of 55 clips & 6 bolts with nuts.	1941	20.00 set
11A-20003	Top center of hood fasteners, Set of 10 clips & 2 bolts with nuts...	1941	6.00 set
11A-20011	Fender, 52 bolts with nuts	1941	22.00 set
11A-20000-A	Convertible trim fasteners kit, Includes 11A-20005, 11A-20003 & 11A-20011	1941	48.00 kit
11A-20000-B	Tudor closed car trim fastener kit includes 11A-20005, 11A-20003, 11A-20011, 11A-20007 & 11A-20008	1941	67.00 kit
11A-20000-C	Fordor trim fastener kit includes 11A-20005, 11A-20003, 11A-20011 11A-20009 & 11A-20010	1941	75.00 kit



TRIM CLIPS 1947-1948 Cars

6A-20005	Body belt fasteners, set of 50 clips & 8 bolts with nuts	47-48	20.00 set
6A-20011	Fender, 38 bolts with nuts	47-48	20.00 set
6A-20001	Front splash apron 8 clips	47-48	5.00 set
6A-20000-A	All body styles trim fasteners kit, includes 6A-20005, 6A-20011 & 6A-20001	47-48	45.00 kit



DOOR & QTR. REVEAL MOLDING CLIPS 1941-1948

Door glass & quarter glass window moldings

11A-20007	2 door straight section includes 36 clips & 4 bolts with nuts.	41-48	12.00 set
11A-20008	2 door curved section includes 24 clips.	41-48	7.50 set
11A-20009	Fordor straight section includes 56 clips & 6 bolts with nuts.	41-48	17.00 set
11A-20010	Fordor curved section includes 34 clips.	41-48	10.00 set



UNIVERSAL MOLDING CLIP

U-29000-CLAK Clip with break points to cut to length as needed 1.00 ea



U-29000-CLAK

HEADLIGHT ASSEMBLIES – STAINLESS STEEL

ORIGINAL STYLE WITH FORD SCRIPT

B-13000-1S	Passenger & commercial, 6 volt, 1 bulb	1932	300.00	pr
B-13000-2S	Passenger & commercial, 6 volt, 2 bulbs	1932	300.00	pr
B-13000-QS	Passenger & commercial, 12 volt, 1 bulb, quartz halogen	1932	325.00	pr
B-13000-QSTS	Passenger & commercial, 12 volt, 2 bulb, (with turn signal) quartz halogen	1932	325.00	pr
40-13000-1S	Passenger, 6 volt, 1 bulb	33-34	300.00	pr
40-13000-2S	Passenger, 6 volt, 2 bulbs	33-34	300.00	pr
40-13000-QS	Passenger, 12 volt, 1 bulb, quartz halogen	33-34	325.00	pr
40-13000-QSTS	Passenger, 12 volt, 2 bulbs, (with turn signal) quartz halogen	33-34	325.00	pr



HEADLIGHT ASSEMBLIES – READY FOR PAINT

ORIGINAL STYLE WITH FORD SCRIPT

46-13000-1S	Commercial, 6 volt, 1 bulb, stainless steel rims	33-34	300.00	pr
46-13000-2S-6	Commercial, 6 volt, 2 bulbs, stainless steel rims	33-34	300.00	pr
46-13000-QS	Commercial, 12 volt quartz halogen , 1 bulb, stainless steel rims	33-34	325.00	pr
46-13000-QSTS	Commercial, 12 volt quartz halogen , 2 bulbs (with turn signal) stainless steel rims.....	33-34	325.00	pr



HEADLIGHT RIMS 1932-1936

Polished stainless steel. All rims include rim latch.

B-13001-RM	Cars & pickups	1932	30.00	ea
40-13001-RM	Cars & pickups	33-34	30.00	ea
48-13045	1935 car & 1935-39 pickups * ..	35-39	76.00	pr
68-13045	1936 cars *	1936	90.00	pr

* 48-13045 & 68-13046 rims also include lens retainer clips (40-13061-S or 48-13061-S)

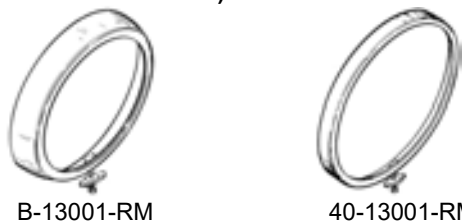

HEADLIGHT RIMS 1937-1939

78-13001-RM	Stainless steel.....	37-39	30.00	ea
91A-13001-RM	Deluxe, stainless steel	1939	30.00	ea

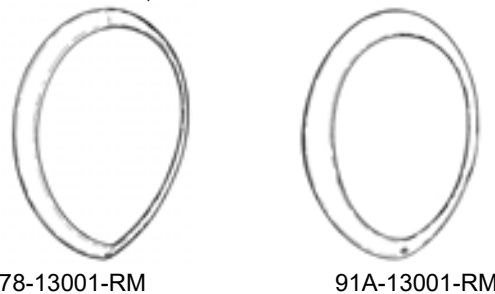

HEADLIGHT RIMS 1940-1948

Includes mounting screws 01A-13026-S.

01A-13045-B	1940 deluxe & Mercury, sold each or pairs chrome as original	1940	140.00	pr
01A-13045-A	1940 standard & 1940-1941 pickup, not chromed & ready to paint	1940	140.00	pr

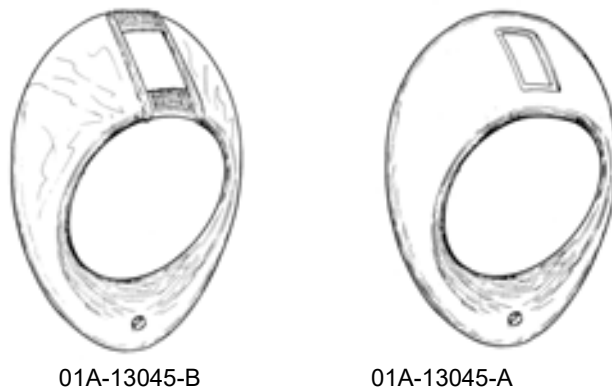

11A-13045	2 rib style, stainless steel *	1941	75.00	pr
21A-13045	3 rib style, stainless steel *	1942	75.00	pr
51A-13045	1 rib style, stainless steel *	1946	75.00	pr
6A-13045	Smooth, stainless steel *	47-48	75.00	pr
01A-13018-S	Sealed beam retainer ring, 1940-1957 car and 1940-1956 pickup, polished stainless Steel **	40-57	20.00	ea
01A-13018-C	Retainer ring as above but chrome **	40-57	11.00	ea

**Mounting screws 01A-13018-HK available in next section

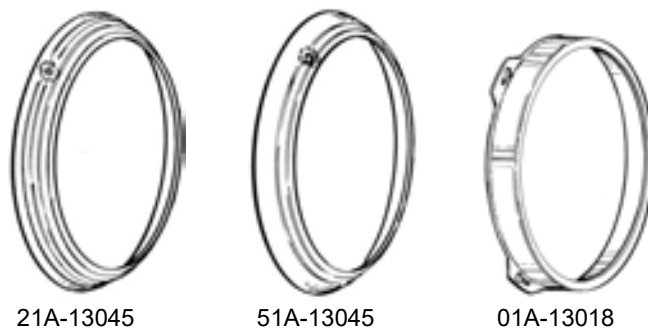

HEADLIGHT SHELL MOUNTING KIT

A-13040-S 12 special polished stainless steel rivet head 10-32 x 1/2" screws & lock nuts, enough for 2 headlights28-34 6.00 kit



HEADLIGHT RIM LATCH REPAIR KITS

All stainless steel parts required to repair one headlight rim
 A-13044-ASS 1928-1929 & 1933-193428-34 5.50 kit
 A-13044-BSS 1930-1932, 1935-193630-36 5.50 kit



A-13044-ASS

A-13044-BSS

HEADLIGHT MOUNTING BOLT SETS

A-13001-MBK Replacement hollow mounting bolts & nuts28-32 11.50 set
 40-13001-MBK Replacement hollow mounting bolts & nuts33-34 11.50 set



A-13001-MBK
 40-13001-MBK

HEADLIGHT UPPER CLIPS

B-13001-C Holds rim to shell30-32 2.50 ea
 40-13001-C Holds rim to shell 1934 2.50 ea



B-13001-C



40-13001-C

HEADLIGHT INNER RINGS

B-13001-IR Must be spot welded to the outer housing 1932 9.00 ea
 40-13001-IR Must be spot welded to the outer housing33-34 9.00 ea

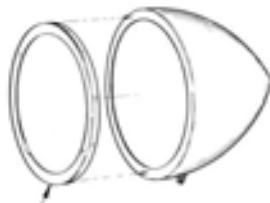

inner ring

HEADLIGHT MOUNTING SCREWS

Sealed beam retainer ring mounting screws
 01A-13018-HK Stainless steel screws, mounts both rings, set of 640-48 5.00 set



HEADLIGHT RIM SCREWS

01A-13026-S 1937-1940 passenger and 1940-1941 pickup, stainless steel, fastens headlight rim to bucket 37-41 1.00 pr



HEADLIGHT BUCKETS 1939-1941

INCLUDES: Housing, Reflector Retainer, Special Adjusting Screws and Springs (3 each), Lens and Headlight Rim Mounting Brackets, Black Wire Flex Conduit (mounted to bucket with collars), Gasket and Retainer Bail for Headlight Lens, Gasket (bucket to fender), Screws and Lock Washers (mounts bucket to fender, 4 each), Black Enamel Finish

78-13026-PR 1937-1938 passenger & 1939 standard 37-39 225.00 pr
 91A-13026-PR Deluxe 1939 225.00 pr
 01A-13026-PR 1940 passenger & 1940-1941 pickup 40-41 250.00 pr

HEADLIGHT BUCKETS DESIGNED FOR 12 VOLT HALOGEN LIGHTS ALSO AVAILABLE. PLEASE INQUIRE



78-13026

91A-13026

01A-13026

HEADLIGHT / TAILLIGHT CONDUIT REPAIR KIT

Includes black loom with special collars.
 78-14597-RK 1937-1938 Passenger & 1940-1947 Pickup 37-48 20.00 ea



HEADLIGHT BUCKET HARDWARE KIT

Kits include all the necessary screws, clips, brackets and rivets to mount the glass lens and headlight rim in place on the headlight bucket.

78-13061-K 1937-1938 deluxe & 1937-1939 standard, 23 piece kit, does one bucket 37-39 15.00 kit
 91A-13061-K Deluxe, 29 piece kit, does one bucket 1939 15.00 kit



78-13061-K

91A-13061-K

01A-13026-HK

MOUNTING KIT (FOR BUCKET ONLY)

Includes screws & lock washers needed to mount the headlight bucket to the fender. Kit does one headlight bucket.
 01A-13026-HK 1937-1940 passenger & 1940-1941 pickup 37-41 3.00 kit

HEADLIGHT AIMING SCREWS & SPRINGS

78-13032-HK	1937-1938 passenger, 1939 standard & deluxe, 6 aiming screws with 6 springs, does two headlights	37-39	15.00 kit
01A-13032-HK	1940 passenger & 1940-1941 pickup, 4 aiming screws with 8 springs, does two headlights	40-41	ASK
11A-13031	Headlight bucket spring 1941-1948 cars & 1942-47 pickup	41-56	2.00 ea



HEADLIGHT RIM REPAIR BRACKETS

Kit is complete for 2 rims

78-13026-R	Passenger**	37-39	6.00 kit
**This kit included in 78-13061-K & 91A-13061-K on previous page			
01A-13026-R	1940 passenger & 1940-1941 pickup	40-41	6.00 kit



HEADLIGHT BUCKET TO FENDER GASKETS

78-13044	1937-38 all cars & 39 Standard	37-39	14.00 pr
91A-13044	Deluxe	1939	14.00 pr
01A-13044	1940 passenger & 1940-1941 pickup	40-41	8.00 pr
11A-13044	1941-1948 passenger and 1942-1947 pickup	41-48	8.00 pr

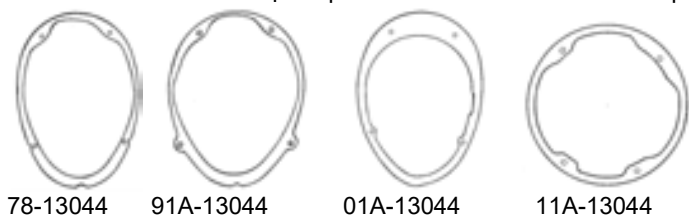

HEADLIGHT REFLECTOR RETAINER RINGS

Stamped steel, painted black. Includes: 3 aiming screws with 3 springs.

78-13030	1937-1938 passenger and 1939 standard	37-39	25.00 ea
91A-13030	Deluxe	1939	25.00 ea



HEADLIGHT REFLECTORS (ORIGINAL STYLE)

B-13027	Passenger & pickup, single bulb..	1932	25.00 ea
B-13028	Passenger & pickup, two bulb	1932	25.00 ea
40-13027	Passenger & pickup, single bulb..	33-34	25.00 ea
40-13028	Passenger & pickup, two bulb	33-34	25.00 ea
48-13028	1935-1936 passenger and 1935-1939 pickup, two bulb	35-39	25.00 ea
78-13028	Passenger, two bulb	37-39	25.00 ea



1 Bulb reflector

2 Bulb reflector

HEADLIGHT REFLECTOR KITS (NON-ORIGINAL)

For conversion to quartz halogen. Kits include:

2 reflectors, special sockets with wire, 2 55W/60W quartz halogen bulbs, 2 cork/neoprene gaskets and 2 wiring plugs.

B-13027-QK12	Car & pickup 12 volt*	1932	100.00 kit
40-13027-QK12	Car & pickup 12 volt*	33-34	100.00 kit
48-13027-QK12	1935-1936 car and 1935-1939 pickup 12 volt*	35-36	100.00 kit
78-13027-QK12	Car 12 volt **	37-39	100.00 kit
78-13027-QK6	Car 6 volt **	37-39	120.00 kit

Kits as above except to have turn signals equipped in reflectors.

B-13027-QK12TS	Car & pickup 12 volt *	1932	115.00 kit
40-13027-QK12TS	Car & pickup 12 volt *	33-34	115.00 kit
48-13027-QK12TS	1935-1936 car and 1935-1939 pickup 12 volt *	35-36	115.00 kit
78-13027-QK12TS	Car only 12 volt **	37-39	115.00 kit
78-13027-QK6TS	Car only 6 volt **	37-39	135.00 kit

*For spare headlight bulbs see 40-13007-Q12 or, directional bulbs see 11A-13465-A12V in bulb section.

**For spare headlight bulbs see B-13007-Q12 or B-13007-Q6, directional bulbs see 11A-13465-A12V in bulb section.



78-13027-QKTS

HEADLIGHT REFLECTOR MOUNTING CLIPS

These clips position the reflector and hold it while installing glass lens & rim, 6 piece set serves both headlights.

48-13029-S	1935-1936 passenger and 1935-1939 pickup	35-39	10.00 set
------------	--	-------	-----------



HEADLIGHT LENS PARTS

B-13066	Cork gasket, 1932-1936 passenger & 1932-1939 pickup ..	32-39	7.50 pr
78-13066	Cork gasket, passenger	37-39	7.50 pr
78-13066-A	Hollow core rubber gasket, passenger	37-39	9.00 pr
78-13067	Retainer bail.....	37-39	12.00 pr

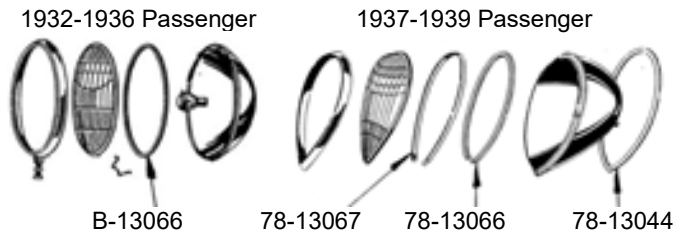

LENS RETAINER CLIP SETS

6 Piece sets

B-13061-S	Car & pickup,	28-32	2.50 set
40-13061-S	Car & pickup,	33-34	2.50 set
48-13061-S	1935-36 car & 35-39 pickup	35-36	3.00 set

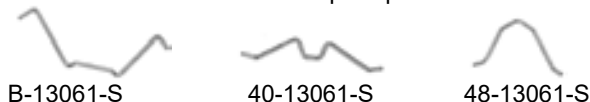

HEADLIGHT LENS (ORIGINAL STYLE)

With FORD Script

B-13060-S	Passenger & pickup	1932	19.00 ea
40-13060-S	Passenger & pickup	33-34	19.00 ea
48-13060-S	1935 passenger & 1935-1939 pickup	35-39	19.00 ea
68-13060-S	Passenger.....	1936	19.00 ea
78-13060-S	1937-1938 passenger & 1939 standard	37-39	19.00 ea
78-13060-CL	Same as 78-13060 except clear lens for use with halogen bulbs.....	37-39	25.00 ea
91A-13060-S	Deluxe.....	1939	19.00 ea
91A-13060-CL	Same as 91A-13060 except clear lens for use with halogen bulbs.....	37-39	25.00 ea

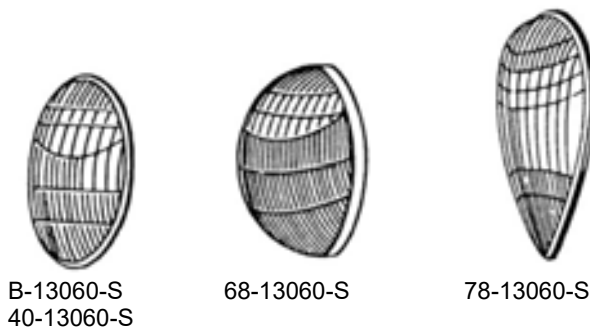

1932 DROPPED HEADLIGHT BAR

Stainless steel dropped headlight bar with a brilliant polish for street rods. Includes (4) stainless mounting bolts (B-13119-SS) and pads (B-13130), 42" long, tip-to-tip. Made correctly for proper fit by Bob Drake.

B-13114-S	Dropped stainless steel.....	1932	220.00 ea
-----------	------------------------------	------	-----------

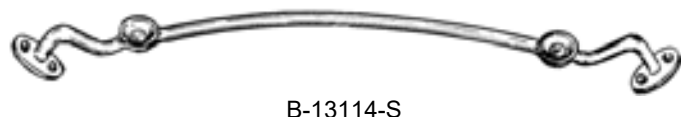

HEADLIGHT BAR BOLTS

Includes hardware with the same finish as the bolt. Forged steel or stainless steel

B-13119-BK	Bar bolts, 1932 passenger & 1932-34 pickups, black oxide...	32-34	3.00 ea
B-13119-SS	1932 passenger & 1932-1934 pickups, stainless steel, set of bolts with nuts & washers.....	32-34	60.00 set

HEADLIGHT STAND TO FENDER BOLTS

Includes hardware with the same finish as the bolt. Forged steel or stainless steel

40-13119-BK	1933-1935 passenger and 1935-1937 pickups, black, hollow for horn wiring	33-37	5.00 ea
40-13119-BKNH	1933-1935 passenger and 1935-1937 pickups, black, no hole in center	33-37	5.00 ea
40-13119-SS	1933-1935 passenger and 1935-1937 pickups, stainless steel, hollow for horn wiring.....	33-37	7.00 ea
40-13119-SSNH	1933-1935 passenger and 1935-1937 pickups, stainless steel, no hole in center.....	33-37	7.00 ea

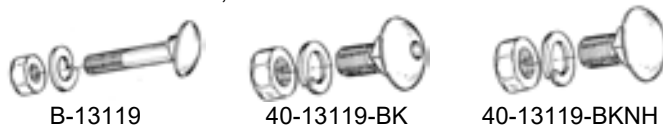

HEADLIGHT MOUNTS

Fits between head light buckets & fenders, die stamped steel.

40-13125/6-SB	"Shorty" style, black, shortened 2" 33-34 cars & 33-37 pickups....	33-37	50.00 pr
40-13125/6-SS	"Shorty" style as above except stainless steel	33-37	60.00 pr
68-13125-A	Passenger cars, original style ..	1936	ASK



HEADLIGHT BAR/STAND PADS

High quality rubber with molded beaded edges.

B-13130	1932 passenger & 1932-1934 pickups	32-34	4.00 pr
40-13130	1933-1934 passenger and 1935-1937 pickups	33-37	4.00 pr
48-13130	Passenger	1935	4.00 pr
68-13130	Passenger	1936	4.00 pr
81C-13130	Pickup.....	38-39	12.00 pr



HEADLIGHT SOCKETS, WIRING & GROMMETS

Note: (2) each of below items required per car

B-13076	Socket assembly, 2 bulb	1932	16.00 ea
46-13076-B	Wiring, 2 bulb, use original sockets.....	33-34	11.50 ea
B-13075-2	Replacement socket, double contact (Uses B-13007 Bulb)*.....	32-34	12.00 ea
B-13075-1	Replacement parking light socket, single contact (Uses B-13466 bulb)*	32-34	12.00 ea

***Note: Requires 3/4" dia. hole for installation**



B-13076



B-13075-1
B-13075-2

48-13076-WIRE	Wire set, NO sockets 1935-1936 cars & 1935-1939 pickup.....	35-39	11.50 ea
91A-13076-WIRE	Wire set with parking light socket but NO headlight socket, cars only	37-39	22.00 ea



48-13076-WIRE



91A-13076-WIRE

01A-13076	Socket assembly, 1940 passenger & 1940-1941 pickup ...	1940	24.25 ea
11A-13076	Socket assembly, 1941-1948 passenger & 1942-1947 pickup ...	41-48	19.00 ea
01A-13076-U	Sealed beam socket & pigtail, replacement style.....	40-48	6.00 ea



01A-13076



11A-13076



01A-13076-U

8C-13078	Headlight wire grommet, fits in 5/8" diameter hole	39-41	4.00 ea
B-14603	Headlight wire grommet as above except fits in 1" diameter hole	39-41	1.50 ea
51A-13077	Headlight wire grommet, fits in 7/8" diameter hole	41-48	2.00 ea



8C-13078 & B-14603



51A-13077

HEADLIGHT CONDUIT SET & PARTS

B-14578-S	Conduit set, stainless steel, 32 pass and 1932-1934 pickup	32-34	13.00 set
B-13065	Headlight connector for conduit, fits in hole in bucket	1932	4.50 ea
B-14567-CS	Radiator shell grommets, 1932 passenger & 1932-1934 pickup ...	32-34	1.50 pr
B-14584	Headlight plug, 3 hole type, 1932 passenger & 1932-1934 pickup ...	1932	2.50 ea



B-14578-S



B-13065



B-14567-CS



B-14584

HEADLIGHT SWITCH

A-11655/67	Light switch body housing	32-39	16.00 ea
01A-11652	Headlight switch & wire assembly, duplicate of original, accepts reproduction or original knobs	1940	35.00 ea
11A-11652	Headlight switch, no wire, accepts original style knob	41-48	39.00 ea
7RA-11654	Headlight switch, no wire. Fused replacement type with plastic knob. 1947-1948 passenger & 1942-1948 pickup ...	42-48	11.00 ea

Note: For light switch knobs see Dash Knob section.



A-11655/67

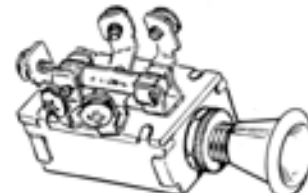

7RA-11654



11A-11652



01A-11652

LIGHT SWITCH & HORN ROD PARTS

B-3616	Light switch & horn rod assembly....	1932	65.00 ea
B-3642	Spider spring.....	32-39	1.00 ea
B-3643	Spider.....	32-39	3.00 ea
B-3644	Spider retainer, U-shaped.....	32-38	.50 ea



B-3642



B-3643



B-3644

B-3647	Bail, holds switch to bottom of steering column.....	32-36	2.00 ea
78-3647	Bail, cadmium.....	37-39	4.00 ea
B-3569	Light switch bracket (This is the flange that the light switch B-11655-S fits into)	29-37	4.00 ea



B-3647



78-3647



B-3569

DIMMER SWITCH

81A-13532	Passenger and commercial	38-48	15.00 ea
-----------	--------------------------------	-------	----------



81A-13532

ORDER & INFORMATION LINE 1-508-278-3980 TOLL FREE 1-800-508-3980 Email: joesantique@charter.net

PARKING LIGHT LENS

01A-13082	Car & pickup, glass	1940	7.00 ea
11A-13082	Car, clear glass	1941	9.00 ea
11A-13082-AMB	Car, amber glass *	1941	9.00 ea
11C-13082	Pickup, glass	1941	7.50 ea
21A-13208	Cars, plastic	42-46	10.00 ea
21T-13208	1947-1948 passenger and 1942-1947 pickup, clear glass	42-48	9.50 ea
21T-13208-AMB	Same as above except amber glass *	42-48	9.50 ea

*Amber glass typically used for directional lights



PARKING LIGHT LENS BEZELS

Die cast, chrome plated, clips included.

01A-13084	1940 standard, 1940-1941 pickup & 1941 sedan delivery	40-41	55.00 pr
-----------	--	-------	----------



PARKING LIGHT LENS GASKETS & CLIPS

01A-13085	Gasket, 1940 car and 1940-1941 pickup	40-41	3.50 pr
01A-13082-CK	Clip kit, 3/16" hole, 1940 Deluxe car, 6 pieces	1940	3.75 kit
350786-AS7	Clip kit, 1/8" hole, 1940 Standard car & 1940-41 pickup, 6 pieces	40-41	3.75 kit



01A-13085



350786-AS7 or 01A-13082-CK

11A-13211	Gasket, passenger	1941	5.00 pr
21A-13211	Gasket, passenger	42-46	5.00 pr
21T-13211	Gasket, 1947-1948 passenger and 1942-1947 pickup	42-48	5.00 pr



11A-13211



21A-13211



21T-13211

PARKING LIGHT ASSEMBLIES (ORIGINAL STYLE)

11A-13200	Passenger	1941	40.00 ea
6A-13200-T	1947-1948 passenger & 1942-1947 pickup, same as above except dual wire to use with turn signal, also includes 21C-13217-R pads (sold in pairs)	42-48	60.00 pr



11A-13200



6A-13200-T

Note: Above parking light assemblies have glass lens.

PARKING LIGHT SOCKET REPAIR KITS

21A-13234	25" long, 1wire, 1 washer	42-48	7.50 kit
59A-13234	16" long, 1 wire, 1 washer	46-48	7.50 kit

PARKING LIGHT PADS & BOOT

11A-13217	Pads, rubber, passenger	1941	6.00 pr
21C-13217-R	Pads, rubber, 1947-1948 passenger & 1942-1947 pickup ...	42-48	8.50 pr
51A-13200-RP	Pads, rubber, passenger	1946	20.00 pr
6A-13225	Boot, passenger	42-48	15.00 pr



PARKING/TURN SIGNAL LIGHTS (NON-ORIGINAL)

Rod-Lites are the perfect solution for the problem of parking lights & turn signals on street rods or restorations. Rod-Lites can be adapted to fit on bumper braces, front splash aprons and headlight bars. Rod-Lites are die cast & chrome plated for superior quality. They feature slotted stainless steel screws & installed 12V bulbs. The medium Rod-Lites have dual filament bulbs and amber lens for use as turn signals or red lens for use as stop lights. Wires pass through the mounting bolt for a clean Hi-Tech look. See HR-13465-6V for 6 Volt dual filament bulbs.

HR-13302-S	Small, single filament, AMBER lens 1-3/4" w X 1-1/8"h X 1-5/8"d	10.00 ea
HR-13302-MTS	Medium, dual filament, AMBER lens 2-1/4" w X 1-1/4"h X 1-3/4"d	12.00 ea
HR-13302-MTS-RD	Medium, dual filament, RED lens 2-1/4" w X 1-1/4"h X 1-3/4"d	12.00 ea



Typical Rod-Lite

COWL LIGHT ASSEMBLIES

Show quality cowl lights complete with stainless steel housings and rims, die cast chrome arms, correct glass lens, reflectors, bulbs, wiring and nuts. 12 volt bulbs are installed—6 volt bulbs B-13466-6V (single element) or HR-13465-6V (dual element) may be ordered separately, see bulb section.

B-13302	12 Volt bulb, single wire	1932	ASK
40-13302	12 Volt bulb, single wire	33-34	ASK
B-13302-TS	12 Volt bulb, dual wires, for use with turn signal	1932	95.00 pr
40-13302-TS	12 Volt bulb, dual wires, for use with turn signal	33-34	95.00 pr



1933-1934 Cowl light assembly

COWL LAMP MOUNTING PADS

B-13324	Mounting pad, rubber, <u>except</u> 3-window coupe	1932	3.00 pr
B-13324-3W	Mounting pad, rubber, 3-window coupe <u>only</u>	1932	5.00 pr
40-13324	Mounting pad, rubber, all styles ...	33-34	3.00 pr



B-13324-S



B-13324-3W



40-13324-S

ORDER & INFORMATION LINE 1- 508-278-3980

TOLL FREE 1-800-508-3980

Email: joesantique@charter.net

COWL LIGHT PARTS

B-13306	Rim	1932	12.50 ea
40-13306	Rim	33-34	12.50 ea
B-13308	Glass lens	1932	6.00 ea
40-13308	Glass lens	33-34	6.00 ea
B-13309	Lens gasket.....	1932	1.75 pr
40-13309	Lens gasket.....	33-34	1.75 pr
A-13316-S	Lens retainer clips, 6 piece set.....	32-34	2.50 set
B-13315	Reflector.....	1932	10.00 ea
40-13315	Reflector.....	33-34	10.00 ea
B-13322	Arms, chrome, with washers and nuts	1932	50.00 pr
40-13322	Arms, chrome, with washers and nuts	33-34	50.00 pr
A-13302-BT	Screw set, special small head 10-32 screws that fasten the cowl light head to the arm, set includes 6 screws.....	28-32	2.00 set
B-13412	Pigtail set, cotton braided wire, does both lights.....	32-34	4.50 ea

NOTE: SEE WIRING SECTION FOR COWL LIGHT WIRES.



Rim A-13316 Lens..Reflector Pigtail

TURN SIGNAL SWITCHES

For 7-wire combination stop, tail & turn signal systems. Heavy duty, die cast, black housing with chrome plated lever. Built in hazard warning switch and hazard warning pilot light with universal steering column clamp.

U-13340-6V	6 Volt, includes flasher	65.00 ea
U-13340-12V	12 Volt, includes flasher	65.00 ea
A-13350-6V	Flasher, 6 Volt, 3 terminal, import.....	7.00 ea
A-13350-6V-US	Flasher, 6 Volt, 3 terminal, US mfg	16.00 ea
A-13350-BEEP	Flasher, 6 volt with beep reminder	39.00 ea
A-13350-12V	Flasher, 12 Volt, 3 terminal, import.....	6.50 ea
A-13350/12BEEP	Flasher, 12 volt with beep reminder.....	30.00 ea
BE-14492	Switch provided with wiring of proper length for easy interface into original style headlight and body harnesses	280.00 kit



U-13340-6V & 12V



A-13350-6V & 12V

TURN SIGNAL LIGHT CONVERSION KITS

Modification kits to mounts lights in front of car

B-13303-TS	Mounts in cowl lights with 12V bulbs, does both lights.....	1932	35.00 kit
40-13303-TS	Mounts in cowl lights with 12V bulbs, does both lights.....	33-34	35.00 kit
40-13200-T	Passenger & pickup, mounts bulb & socket is inside horn, hidden behind screen, does both horns, 12V bulbs.....	33-35	40.00 kit
01A-13200-T	1940 passenger & 1940-1941 pickup, mounts in original parking light with socket & wire, includes 12V yellow bulbs, does both headlights	40-41	35.00 kit
68-16156-BT	Mounts lights in behind existing horn grilles (not included, 12 volt yellow bulbs.....	1936	80.00 kit

HORN ASSEMBLIES

Horn assemblies have chrome top & chrome projector mouth.

40-13802-AL	6 Volt, left, driver's side *.....	33-34	195.00 ea
40-13802-AR	6 Volt, right, passenger side * ..	33-34	195.00 ea
40-13802-BL	12 Volt, left, driver's side	33-34	195.00 ea
40-13802-BR	12 Volt, right, passenger side...	33-34	195.00 ea
48-13802-AL	6 Volt, left, driver's side, 1935 passenger & 1935-1937 pickup *	35-37	195.00 ea
48-13802-AR	6 Volt, right, passenger side, 1935 passenger & 1935-1937 Pickup *	35-37	195.00 ea
48-13802-BL	12 Volt, left, driver's side, 1935 passenger & 1935-1937 pickup	35-37	195.00 ea
48-13802-BR	12 Volt, right, passenger side, 1935 passenger & 1935-1937 pickup	35-37	195.00 ea

* These 6 volt horn require horn relay listed below

HORN BELL COVER & PROJECTOR

40-13809-L	Cover, chrome, "Sparton", LH.....	33-35	15.00 ea
40-13809-R	Cover, chrome, "Sparton", RH.....	33-35	15.00 ea
40-13810	Projector, chrome/black, includes screen, cars	1934	65.00 ea
48-13810	Projector, as above except for 1935 cars & 1935-1937 pickup	35-37	65.00 ea

Bell cover Mounting bracket



Screen Projector B-13829 & 48-13829 91A-13912

HORN MOUNTING BRACKETS & REPAIR KITS

B-13805-A	AH-OOH-GAH horn bracket	1932	20.00 ea
40-13830	Bracket, RH, passenger side.....	33-34	22.00 ea
40-13831	Bracket, LH, driver's side.....	33-34	22.00 ea
48-13830	Bracket, RH, passenger side.....	1935	22.00 ea
48-13831	Bracket, LH, driver's side.....	1935	22.00 ea
50-13830	Bracket, RH, passenger side, pickup	35-36	22.00 ea
50-13831	Bracket, LH, driver's side, pickup	35-36	22.00 ea
68-13830	Bracket, RH, passenger side.....	1936	35.00 ea
68-13831	Bracket, LH, driver's side.....	1936	35.00 ea
B-13829	Horn bracket repair kit	32-34	10.00 kit
48-13829	Horn bracket repair kit	35-40	10.00 kit
91A-13912-S	Horn grommets at support bracket, rubber, cars only	39-48	6.00 pr

HORN SCREENS

40-13840	Stainless steel	33-34	7.00 ea
48-13840	1935 passenger & 1935-1937 commercial, stainless steel.....	35-37	7.00 ea

HORN RELAY ASSEMBLIES

7RA-13853	6 Volt	33-48	12.00 ea
2Q-13853	12 Volt	33-48	12.00 ea

TAILLIGHT ASSEMBLIES

For blue dot taillight lens add \$8.00 to above prices & -BD to part numbers.

B-13407	R.H., all stainless steel.....	1932	30.00 ea
B-13408	L.H., all stainless steel.....	1932	30.00 ea
B-13407-B	R.H., pickup, station wagon and commercial, black.....	32-42	ASK
B-13408-B	L.H., pickup, station wagon and commercial, black.....	32-42	ASK



B-13407 & B-13407-B B-13408 & B-13408-B

40-13407	R.H., passenger & sedan delivery, all stainless steel.....	33-34	25.00 ea
40-13408	L.H., passenger & sedan delivery, all stainless steel.....	33-34	25.00 ea
48-13407	R.H., 1935-36 passenger, 1946-52 pickup, 1935-48 sedan delivery, black body & stainless steel rim.....	35-48	25.00 ea
48-13408	L R.H., 1935-36 passenger, 1946-52 pickup, 1935-48 sedan delivery, black body & stainless steel rim.....	35-48	25.00 ea



40 & 48-13407

40 & 48-13408

78-13402	R.H., passenger, black.....	1937	35.00 ea
78-13403	L.H., passenger, black.....	1937	35.00 ea



78-13402

78-13403

81A-13405-D	R.H. or L.H., passenger.....	38-39	25.00 ea
01A-13405	R.H. or L.H., passenger.....	1940	28.50 ea



81A-13405

01A-13405

11A-13404	R.H., Chrome housing, 1941 car & 1946-48 sportsman.....	41-48	75.00 ea
11A-13405	L.H., Chrome housing, 1941 car & 1946-48 sportsman.....	41-48	75.00 ea
21A-13405-D	R.H. or L.H.....	42-48	25.00 ea



11A-13405

21A-13405-D

HOT ROD TAILLIGHT ASSEMBLIES

1950 Pontiac style

HR-13405	With plain red lens.....	50.00 pr
----------	--------------------------	----------



HR-13405

TAILLIGHT LENS

Glass as original

B-13450	1932 passenger & 1932-1942 pickup.....	32-42	6.00 ea
40-13450	1933-1936 passenger and 1946-1947 pickup.....	33-47	6.00 ea
78-13450	Passenger.....	1937	6.00 ea
81A-13450	Passenger.....	38-39	6.00 ea



B-13450

40-13450

78-13450

81A-13450

01A-13450	Passenger.....	1940	6.00 ea
11A-13450	Passenger.....	1941	6.00 ea
21A-13450	Passenger.....	42-48	6.00 ea



01A-13450

11A-13450

21A-13450

TAILLIGHT LENS WITH BLUE DOT

All glass with chrome ring and blue dot installed

B-13450-BD	1932 passenger and 1932-1942 pickup.....	32-42	12.00 ea
40-13450-BD	1933-1936 passenger and 1946-1947 pickup.....	33-47	12.00 ea
78-13450-BD	Passenger.....	1937	12.00 ea
81A-13450-BD	Passenger.....	38-39	12.00 ea



B-13450-BD

40-13450-BD

78-13450-BD

81A-13450

01A-13450-BD	Passenger.....	1940	12.00 ea
11A-13450-BD	Passenger.....	1941	12.00 ea
21A-13450-BD	Passenger.....	42-48	12.00 ea



01A-13450-BD

11A-13450-BD

21A-13450-BD

TAILLIGHT RIMS

Die stamped polished stainless steel

B-13448	1932 passenger & 1932-1942 pickup	32-42	5.00 ea
40-13448	1933-1936 passenger and 1946-1952 pickup	33-52	5.00 ea
78-13448	Passenger.....	1937	5.50 ea
81A-13448	Passenger.....	38-39	5.00 ea
01A-13448	Passenger.....	1940	8.75 ea
21A-13448	Passenger.....	42-48	8.75 ea

TAILLIGHT LENS GASKETS

B-13460	1932 car & 1932-42 pickup	32-42	1.50 ea
40-13460-PR	1933-36 car and 1946-52 pickup, inner & outer seal for (1)taillight ..	33-52	5.00 set
78-13460	Passenger.....	1937	1.50 ea
81A-13460	Passenger.....	38-39	1.50 ea
01A-13460	Passenger.....	1940	1.50 ea
11A-13460	Passenger.....	1941	1.50 ea
21A-13460	Passenger.....	42-48	1.50 ea



B-13460



40-13460



01A-13460



21A-13460

LICENSE PLATE LIGHT LENS

B-13445	1932 passenger, 1932-1942 pickup	32-42	3.50 ea
40-13445	1933-1936 passenger and 1946-1947 pickup	33-47	5.00 ea
78-13445	Passenger.....	1937	5.00 ea
99A-13564	1940-1948 Ford and 1939-1940 Mercury.....	40-48	6.00 ea



40-13445



99A-13564

LICENSE PLATE LENS RETAINER CLIPS

Holds lens in place. Kit includes 2 stainless screws and 2 clips.

B-13446-S	Passenger.....	1932	1.50 kit
40-13446-S	1933-1937 passenger and 1932-1947 pickup	33-47	1.50 kit

LICENSE PLATE LIGHT GASKETS

B-13447	1928-1932 passenger and 1928-1942 pickup	28-42	1.00 ea
40-13447	1933-1936 passenger and 1946-1952 pickup	33-52	1.00 ea
78-13447	Passenger.....	1937	1.00 ea
01A-13568/9	Passenger.....	40-48	2.00 set



B-13447



40-13447

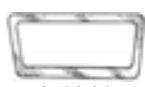

78-13447

TAILLIGHT SCREW KIT

40-13444-SK	Mounts taillight to bracket & rim to taillight housing.....	33-37	2.00 kit
-------------	---	-------	----------



TAILLIGHT HOUSINGS & ORNAMENTS-

1942-1948 Cars

21A-13470-K	Housings with inner backing plates and hardware	42-48	165.00 pr
21A-13476-AS	Trim ornament, stainless steel .	42-48	35.00 pr

For rubber pads to mount housings to fender see 21A-13420/1 on next page



21A-13470-K



21A-13476-AS

TAILLIGHT PIGTAIL WIRE SETS

Pigtails include 1) black wire, 1) green wire, with springs and insulators. Cotton braided sets include the original type cloth/asphalt loom. Sockets sold separately.

A-13410-P	Modern plastic wire.....	28-32	3.50 set
A-13410-C	Cotton braided wire	28-32	4.50 set
A-13410-S	Taillight socket only, for single filament bulbs	28-32	1.00 ea
40-13410-P	Modern plastic wire.....	33-48	3.50 set
40-13410-C	Cotton braided wire	33-48	4.50 set
40-13410-S	Taillight socket only, for dual filament bulbs	33-48	1.00 ea



A-13410-C



40-13410-C



40-13410-S

TAILLIGHT / HEADLIGHT CONDUIT REPAIR KIT

Includes black loom with special collars.

78-14597-RK	Passenger.....	38-48	20.00 ea
-------------	----------------	-------	----------



LICENSE LIGHT SOCKET- PIGTAIL ONLY

This is the replacement wire for the license light socket only. Complete with insulator, spring & original type cloth/asphalt loom. See 91A-14415 or 11A-14415 in wiring section for complete license lamp wire harness through deck lid.

81A-13412	Passenger.....	38-48	3.75 ea
-----------	----------------	-------	---------



TAILLIGHT BRACKET TO FENDER PADS

Super quality rubber with beaded edges for a perfect fit.

40-13520	Passenger.....	33-34	8.00	pr
48-13520	Passenger.....	1935	8.00	pr
68-13520	Passenger.....	1936	7.00	pr
78-13520	Passenger.....	1937	7.00	pr
21A-13420/1	Passenger- use between stock taillight housing 21A-13470-K & fender.....	42-48	8.50	pr
21A-13520	Fits directly against 21A-13405-D taillight when used in custom applications.....		7.00	pr



TAILLIGHT HOUSING TO FENDER (OR BODY) PADS

81A-13520	Passenger.....	38-39	5.00	pr
01A-13420	Passenger.....	1940	8.00	pr
11A-13420	Passenger.....	1941	8.00	pr
99A-13420/1	Passenger, Mercury.....	1939	10.00	pr



TAILLIGHT WIRE SHIELDS

B-13467-BK	Pickup, gloss black.....	28-66	4.50	ea
B-13467-SS	Pickup, stainless steel.....	28-66	7.00	ea



TAILLIGHT REINFORCEMENTS

A-13463	RH & LH, passenger.....	1932	3.00	ea
40-13463	RH & LH, passenger*.....	33-34	20.00	ea
48-16360	RH, passenger*.....	1935	29.75	ea
48-16361	LH, passenger*.....	1935	29.75	ea
68-16360	RH, passenger*.....	1936	29.75	ea
68-16361	LH, passenger*.....	1936	29.75	ea

*These fit from taillight stand to body, inside fender well.

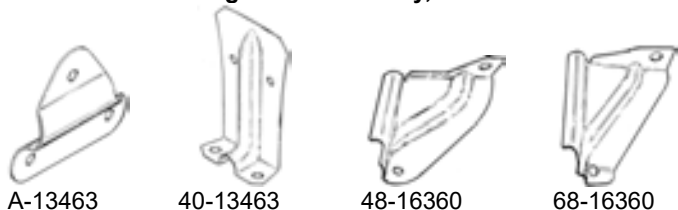

TAILLIGHT BRACE

For use under taillight stand when you have rumble seat

40-13468	Passenger.....	33-34	5.50	ea
----------	----------------	-------	------	----



TAILLIGHT BRACKETS - CARS

B-13470	RH, painted black.....	1932	35.00	ea
B-13470-SS	RH, stainless steel.....	1932	80.00	ea
B-13471	LH, painted black.....	1932	35.00	ea
B-13471-SS	LH, stainless steel.....	1932	80.00	ea
40-13470	RH, with step plate hole, painted black.....	33-34	35.00	ea
40-13470-C	RH, with step plate hole, chrome plated.....	33-34	60.00	ea
40-13471	Fits LH & RH, <u>without</u> step plate hole, painted black.....	33-34	35.00	ea
40-13471-C	Fits LH & RH, <u>without</u> step plate hole, chrome plated.....	33-34	50.00	ea
40-13471-CHP	Fits LH & RH, chopped style, 4" total length, no step plate hole, painted black.....	33-34	45.00	ea



68-13470-A	RH, car, no rumble step mount....	1936	125.00	ea
68-13470-B	RH, car, with rumble step mount..	1936	125.00	ea
78-13470	RH, passenger.....	1937	48.00	ea
78-13471	LH, passenger.....	1937	48.00	ea



TAILLIGHT BRACKETS - PICKUPS

B-13470-B	RH or LH, cast iron, mounts under bed.....	32-37	14.00	ea
50-13470	RH or LH, die stamped.....	35-36	20.00	ea
77-13470	LH only, die stamped.....	1937	20.00	ea



81Y-13470-BK	RH, used with bumper, painted black.....	38-56	8.00	ea
81Y-13470-SS	RH, used with bumper, stainless steel.....	38-56	14.00	ea
81Y-13471-BK	LH, used with bumper, painted black.....	38-56	8.00	ea
81Y-13471-SS	LH, used with bumper, stainless steel.....	38-56	14.00	ea
91C-13470/71-BK	RH or LH, used without bumper, painted black.....	38-56	8.00	ea
91C-13470/71-SS	RH or LH, used without bumper, stainless steel.....	38-56	14.00	ea



HEADLIGHT BULBS

B-13007-D	6 Volt, 50/32 C.P.	28-34	2.00 ea
B-13007-E	12 Volt, 50/32 C.P.	28-34	2.00 ea
48-13007-6	6 Volt, 50/32 C.P.	35-39	2.50 ea
48-13007-12	12 Volt, 50/32 C.P.	35-39	2.50 ea
40-13007-Q12	12 Volt halogen HB5 *		10.00 ea
B-13007-Q6	6 Volt, H-4 quartz halogen**		15.00 ea
B-13007-Q12	12 Volt, H-4 quartz halogen**		10.00 ea

* Used ONLY in Vintique halogen headlight kits B-, 40- & 48-13027-QK.

** Used ONLY in Vintique halogen headlight kit 78-13027-QK.

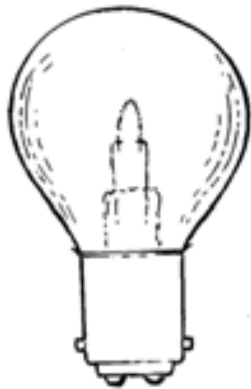

B-13007

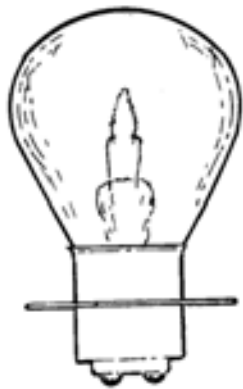

48-13007



B-13007-Q12



40-13007-Q12

HEADLIGHT - SEALED BEAM

09A-13007-6V	6 Volt, 7" lamp*	42-48	12.00 ea
09A-13007-12V	12 Volt, 7" lamp*	42-48	10.00 ea

* Requires removal of outer alignment tabs on face of bulb to fit with 1940 headlight doors.

01A-13007-6V	6 Volt, 7" lamp**	40-UP	24.00 ea
01A-13007-12V	12 Volt, 7" lamp**	40-UP	24.00 ea

** Has FORD script & smooth on face of bulb (with NO alignment tabs) as original for 1940-48.



09A-13007 Sealed beam headlight WITH alignment tabs on face of bulb



01A-13007 Sealed beam headlight WITHOUT alignment tabs on face of bulb

TAILLIGHT BULBS

B-13466-6V	6 Volt, single contact, 3 C.P., straight pins	1932	1.00 ea
B-13466-12V	12 Volt, single contact, 3 C.P., straight pins	1932	1.00 ea

STOP LIGHT BULBS

B-13465-6V	6 Volt, single contact, 21 C.P., straight pins	28-32	1.00 ea
B-13465-12V	12 Volt, single contact, 21 C.P., straight pins	28-32	1.00 ea
40-13465-6V	6 Volt, dual contact, 21-3 C.P., straight pins* (1158)	33-37	2.50 ea
40-13465-12V	12 Volt, dual contact, 21-6 C.P., straight pins* (1157)	33-37	2.50 ea

* Use only original 1933-1937 lights.

11A-13465-6V	6 Volt, dual contact, 21-3 C.P., offset pins** (1154)	33-48	1.00 ea
--------------	---	-------	---------

11A-13465-12V	12 Volt, dual contact, 32-3 C.P., offset pins** (1157)	33-48	1.00 ea
---------------	--	-------	---------

** Use in reproduction 1933-1937 lights

Note: See next page for quartz halogen bulbs

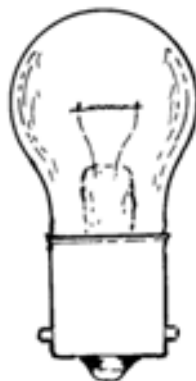

B-13465



40-13465

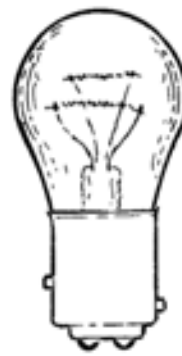

11A-13465



B-13466



HR-13465



40-13730



78-13466



48-15021

Note: Bulbs are shown full size and are either 6 or 12 volt. Lay your old bulb on top for comparison.

COWL/PARKING LIGHT BULBS

B-13466-6V	6 Volt, single contact, 3 C.P., straight pins, 1932-1936 & 1947-1948 passenger, 1935-1939 & 1942-1947 pickup.....	32-48	1.00 ea
B-13466-12V	12 Volt, single contact, 3 C.P., straight pins, 1932-1936 & 1947-1948 passenger, 1935-1939 & 1942-1947 pickup.....	32-48	1.00 ea
78-13466-6V	6 Volt, single contact, 2 C.P., straight pins, 1937-1940 passenger and 1940-1941 pickup.....	37-41	1.50 ea
78-13466-12V	12 Volt, single contact, 2 C.P., straight pins, 1937-1940 passenger and 1940-1941 pickup.....	37-41	1.50 ea

DUAL FILAMENT BULBS

For accessory parking lights with turn signal

HR-13465-6V	6 Volt, dual filament turn signal bulb	1.75 ea
HR-13465-12V	12 Volt, dual filament turn signal bulb	1.75 ea
HR-13465-A12V	12 Volt, dual filament turn signal bulb, <i>amber</i> color	1.75 ea
11A-13465-A12V	12 Volt, dual contact, AMBER 32-3 C.P. offset pins. Large globe, same size as dual filament taillight bulb 11A-13465-12.....	33-48 2.75 ea

INSTRUMENT PANEL BULBS

B-13466-6V	6 Volt, single contact, 3 C.P., straight pins, 1932 and 1935-1939, all.....	32-39	1.00 ea
B-13466-12V	12 Volt, single contact, 3 C.P., straight pins, 1932 and 1935-1939, all.....	32-39	1.00 ea
40-13730-6V	6 Volt, single contact, 6 C.P.	33-34	1.00 ea
40-13730-12V	12 Volt, single contact, 6 C.P.	33-34	1.00 ea
48-15021-6V	6 Volt, single contact, 1 C.P., (#51) 1940 passenger and 1940-1941 pickup.....	40-41	2.00 ea
48-15021-12V	12 Volt, single contact, 1 C.P., (#53) 1940 passenger and 1940-1941 pickup.....	40-41	2.00 ea
78-13466-6V	6 Volt, single contact, 2 C.P.	41-48	1.50 ea
78-13466-12V	12 Volt, single contact, 2 C.P.	41-48	1.50 ea

DOME LIGHT BULBS

B-13466-6V	6 Volt, single contact, 3 C.P., straight pins	32-48	1.00 ea
B-13466-12V	12 Volt, single contact, 3 C.P., straight pins	32-48	1.00 ea

LICENSE PLATE LIGHT BULBS

B-13466-6V	6 Volt, single contact, 3 C.P., straight pins	38-48	1.00 ea
B-13466-12V	12 Volt, single contact, 3 C.P., straight pins	38-48	1.00 ea

BACK UP LIGHT BULBS

B-13465-6V	6 Volt, single contact, 21 C.P., straight pins.....	42-48	1.00 ea
B-13465-12V	12 Volt, single contact, 21 C.P., straight pins.....	42-48	1.00 ea

TAILLIGHT BULBS-QUARTZ HALOGEN

B-13466-Q6	6 Volt, single contact, 20 watt, straight pins.....	1932	20.00 ea
B-13466-Q12	12 Volt, single contact, 20 watt, straight pins.....	1932	ASK

STOP LIGHT BULBS-QUARTZ HALOGEN

B-13465-Q6	6 Volt, single contact, 50 watt, straight pins.....	28-32	20.00 ea
B-13465-Q12	12 Volt, single contact, 50 watt, straight pins	28-32	ASK
40-13465-Q6	6 Volt, dual contact, 50/20 watt, straight pins*	33-37	20.00 ea
40-13465-Q12	12 Volt, dual contact, 50/20 watt, straight pins*	33-37	20.00 ea

*** Use only original 1933-1937 lights.**

11A-13465-Q6	6 Volt, dual contact, 50/20 watt, offset pins** (replaces #1154).....	33-48	20.00 ea
--------------	---	-------	----------

11A-13465-Q12	12 Volt, dual contact, 50/20 watt, offset pins** (replaces #1157).....	33-48	20.00 ea
---------------	--	-------	----------

**** Use in reproduction 1933-1937 lights**

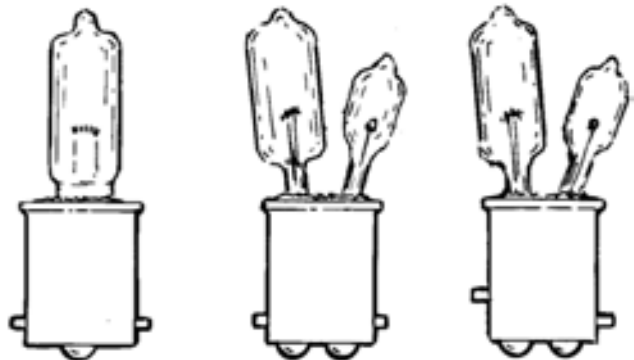

B-13465-Q 40-13465-Q 11A-13465-Q
B-13466-Q

Quartz halogen taillight and stop light bulbs

NOTE ABOUT 6 VOLT HALOGEN BULBS

These bulbs require additional output from your cars electrical system. Typically, a generator is not sufficient and an alternator is needed. A consultation with an experienced mechanic is recommended prior to any changeover!

JOE'S GIFT CERTIFICATES

The perfect solution for the "hard to buy for" relative

BUMPERS

B-17752	Passenger & pickup, front or rear, chrome plated, does not include plugs, see next page	1932	ASK
18-17757	Passenger, front or rear, Chrome plated	1933	ASK
	Stainless steel	1933	ASK
46-17757-A	Pickup, front or rear, Chrome plated	1933	ASK
	Stainless steel	1933	ASK
40-17757	Passenger, front or rear, Chrome plated	1934	300.00 ea
	Stainless steel	1934	500.00 ea
 <p>26"</p>			
40-17757			
46-17757-B	Pickup, front or rear, Chrome plated	1934	ASK
	Stainless steel	1934	ASK
48-17757	Passenger, front or rear, Chrome plated	1935	ASK
	Stainless steel	1935	ASK
50-17757	Pickup, front or rear, Chrome plated	1935	ASK
	Stainless steel	1935	ASK
68-17757	Passenger, front or rear, Chrome plated	1936	ASK
	Stainless steel	1936	ASK
67-17757	Pickup, front or rear, Chrome plated	1936	ASK
	Stainless steel	1936	ASK
78-17757-F	Passenger <u>front only</u> , Pickup front or rear, Chrome plated	1937	ASK
	Stainless steel	1937	ASK
78-17757-R	Passenger, <u>rear only</u> , Chrome plated	1937	ASK
	Stainless steel	1937	ASK
81A-17757	1938 all, 1939 standard and 1938-1939 pickup, front or rear, Chrome plated	38-39	ASK
	Stainless steel	38-39	ASK
91A-17757	Deluxe, front or rear, Chrome plated	1939	ASK
01A-17757	1940 passenger, front or rear, and 1940-1941 pickup, <u>front only</u> , chrome plated	40-41	350.00 ea



01A-17757-F	1940 passenger, front or rear, and 1940-1941 pickup, <u>front only</u> , chrome plated with FORD script, 4" x 1-1/4"	40-41	375.00 ea
-------------	--	-------	-----------



BUMPERS continued

01C-17757	Pickup, <u>rear only</u> , chrome plated	40-41	ASK
21A-17757-CS	Passenger, front, chrome plated	42-46	450.00 ea
51A-17781-C	Passenger, rear, chrome plated, "FORD" script	42-46	ASK
6A-17757-C	Passenger, front, chrome plated	47-48	450.00 ea
6A-17781-C	Passenger, rear, chrome plated	47-48	450.00 ea



FRONT BUMPER BRACKETS

NOTE: The following pricing for brackets only, see previous section for bumper pricing

B-17754/5	Passenger & pickup, 2 pieces..	1932	ASK
-----------	--------------------------------	------	-----

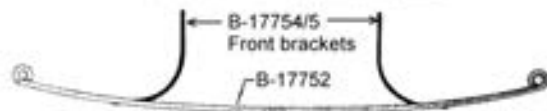

40-17766/7-B	Passenger & pickup, 4 pieces..	1933	ASK
--------------	--------------------------------	------	-----

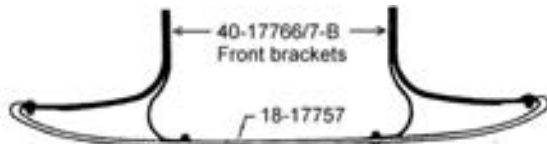

40-17766/7-C	Passenger & pickup, 4 pieces..	1934	ASK
--------------	--------------------------------	------	-----

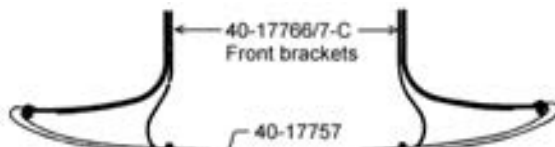

48-17766/7-S	Passenger & pickup, 4 pieces..	1935	ASK
--------------	--------------------------------	------	-----

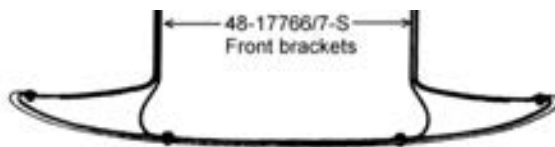

FRONT BUMPER BRACKETS continued

Note: Pricing shown below are for brackets only, See previous page for bumper pricing.

68-17766/7-S Passenger & pickup, 4 pieces .. 1936 ASK

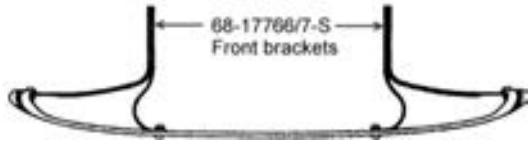

78-17766/7-S Passenger & pickup, 4 pieces .. 1937 ASK

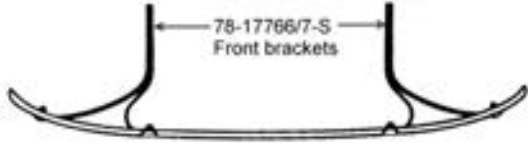

81A-17766/7-S 1938 all styles, 1939 standard and 1938-1939 pickup, 4 pieces 38-39 ASK



91A-17766/7-S Deluxe passenger, 4 pieces 1939 ASK
 01A-17766-AK 1940 Standard passenger & 1940-1941 pickup, 4 pieces 40-41 160.00 set
 01A-17766-BK 1940 Deluxe passenger, 4 pieces 1940 160.00 set

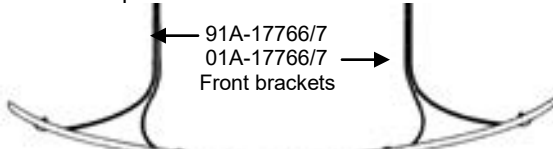

Typical 1936-40 front bumper brackets shown attached to bumper

REAR BUMPER BRACKETS

NOTE: The following pricing for brackets only, see previous section for bumper pricing. Plain steel except as noted.

B-17821/2 Passenger, 2 pieces 1932 ASK
 CHP-17821/2-C Pass, chopped to bring bumper 3" closer to body, chrome 1932 ASK

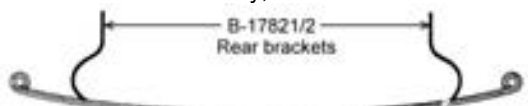

40-17787 Passenger, 2 pieces 1933 ASK

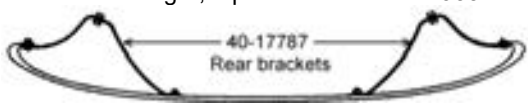

40-17787-C Passenger, 2 pieces 1934 ASK
 40-17787-V Victoria, 2 pieces 1934 ASK

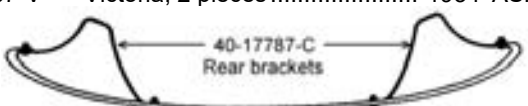

REAR BUMPER BRACKETS continued

Note: Pricing shown below are for brackets only,

48-17787 Passenger, 2 pieces 1935 ASK

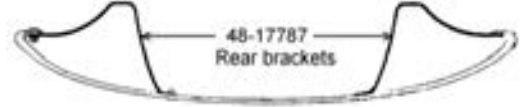

68-17787 Passenger, 2 pieces 1936 ASK

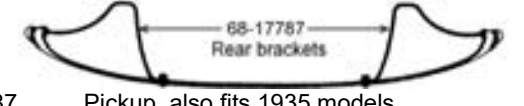

67-17787 Pickup, also fits 1935 models 4 pieces 1936 ASK



78-17787 Passenger, 4 pieces 1937 ASK

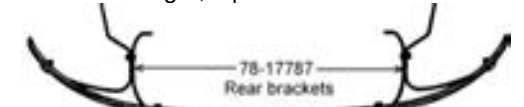

77-17787 Pickup, 4 pieces 1937 ASK



81A-17787 1938 all styles & 1939 standard, 4 pieces 38-39 ASK

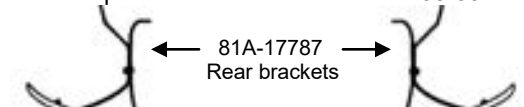

91A-17787 Deluxe, 4 pieces 1939 ASK

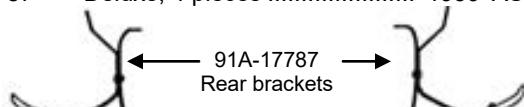

81Y-17787 Pickup, 4 pieces 38-41 ASK

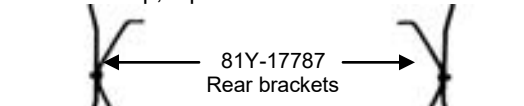

01A-17787 Passenger, 4 pieces 1940 155.00 set

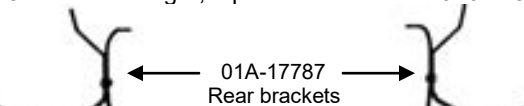

BUMPER END PLUG-1932

B-17760-SS Polished stainless steel 1932 5.00 ea



BUMPER GUARDS

40-17795-E	Passenger, painted grooves.....	33-34	50.00 ea
48-17996	Passenger, painted grooves.....	1935	50.00 ea
68-17996	Passenger, painted grooves.....	1936	ASK
78-17996	Passenger	1937	50.00 ea
91A-17996	Deluxe	1939	50.00 ea
01A-17996	Passenger	1940	50.00 ea
6A-17984/5-A	Passenger, set of 2 (RH & LH)...	47-48	100.00 set
48-17996-HK	Bumper guard bolt kit, black oxide, correct 1 3/8" bolt length, 2 bolts & 2 lock washers	35-40	15.00 kit

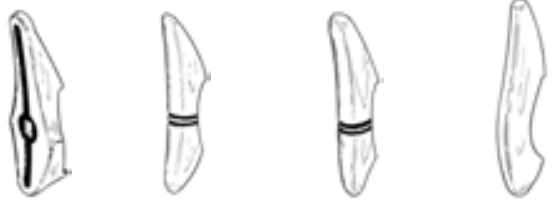

40-17995-E 48-17996 68-17796 78-17996



91A-17996 01A-17996 6A-17984/5-A 48-17996-HK

BUMPER BOLTS

B-17758-K-2	Stainless cover, set of 2 with washers and nuts. 2 bolts per bumper	1932	30.00 set
B-17758-K	Bolts as above but set of 4	1932	60.00 set
40-17758	Solid stainless 1/2"-20 thread 2" long, round head, use with bumper guards*	33-34	6.00 ea
48-17758	Stainless cover, oval head, with washer & nut, 1-1/4" *	33-40	6.50 ea
48-17758-SS	Same as above (48-17758) except solid stainless steel	33-40	10.00 ea
BB-17758-SS	Solid stainless steel 1/2 -13 x 1 1/2" long, big trucks only	32-56	6.00 ea



B-17758-K 40-17758 48-17758
BB-17758-SS

11A-17758-SS	Stainless cover, outer, 1-1/4" * ..	41-48	9.50 ea
11A-17908-K	Stainless cover, 2-1/2" * (4 set)	1941	75.00 set

NOTE: 11A-17758-SS & 11A-17908-K bolt heads are NOT angled



11A-17758-SS 11A-17908

BUMPER END MOUNTING BOLT

40-17758-EB	Black oxide steel as original	33-36	12.00 kit
18-17758-KT	Stainless steel, 1-1/2"	33-36	15.00 kit



*Length of bolt from under head (shank length)

BUMPER TIPS

01A-18383	Chrome, set of 4	1940	250.00 set
-----------	------------------------	------	------------



FRONT BUMPER BRACKET GROMMET SETS

48-17772/3-S	Cars	1935	13.00 pr
68-17772/3-S	Cars 1936-1937 & 1938 Std.....	36-38	13.00 pr
81A-17772/3-S	1938 deluxe & 1939 standard ..	38-39	13.00 pr
91A-17772/3-S	1939 deluxe & 1940 all cars, and 1940-1941 pickup	39-41	13.00 pr
11A-17772/3-S	Cars	1941	13.00 pr
50-17772/3-S	Pickup	35-37	13.00 pr
81C-17772/3-S	Pickup	38-39	13.00 pr



48-17772/3-S 91A-17772/3-S 50-17772/3-S

FRONT BUMPER BRACKET TO PAN CUSHION

21A-17749-B	Passenger, set of 4	42-48	10.00 set
-------------	---------------------------	-------	-----------

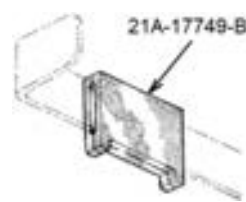

REAR BUMPER BRACKET GROMMET SETS

78-17792/3-S	1937 all styles & 1938-1940 coupe & convertible	37-40	16.00 pr
81A-17792/3-S	1938-1940 tudor & fordor sedan	38-40	13.00 pr
01A-17792	Sedan delivery	40-41	30.00 pr
11A-17792/3-S	Sedan, coupe & convertible	1941	13.00 pr



78-17792/3-S 81A-17792/3-S 11A-17792/3-S

REAR GRAVEL DEFLECTOR TO BUMPER SEAL

6A-17832	Car, extruded rubber	42-48	18.00 ea
----------	----------------------------	-------	----------



FRONT GRAVEL DEFLECTOR & TRIM

51A-17744-B	Front gravel deflector, die stamped, 1 piece.....	46-48	200.00 ea
51A-8196-A	Stainless trim for above	46-48	125.00 ea

FRONT LICENSE PLATE BRACKETS

B-5034-B	Black, passenger & pick-up.....	1932	24.00 ea
B-5034-SS	Stainless steel, passenger & pick-ups.....	1932	29.00 ea
40-5034-B	Black, passenger & pick-up.....	33-36	20.00 ea
40-5034-SS	Stainless steel, passenger & pick-up.....	33-36	24.00 ea

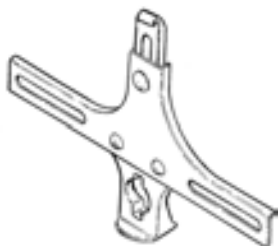

B-5034

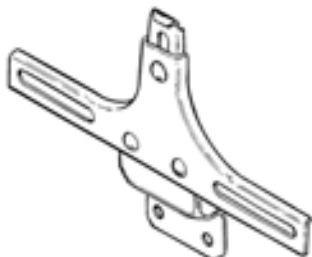

40-5034

78-5034-B	Black, 1937-1938 all cars, 1939 Standard & 1937-1939 pickup.....	37-39	ASK
78-5034-SS	Stainless steel, 1937-1938 all cars 1939 Standard & 1937-1939 pick-up.....	37-39	ASK
91A-5034-B	Black, 1939 deluxe, 1940 all, and 1940-1941 pick-up.....	39-40	20.00 ea
91A-5034-SS	Stainless steel, 1939 deluxe, 1940 all & 1940-1941 pickup.....	39-40	24.00 ea



78-5034

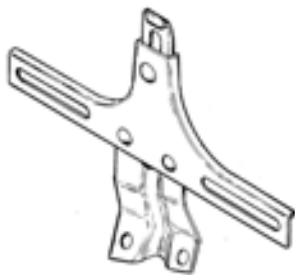

91A-5034

REAR LICENSE PLATE BRACKETS

A-13406-B	1932-1956 pickup, 1932-1948 station wagon, black.....	32-56	7.50 ea
A-13406-SS	1932-1956 pickup, 1932-1948 station wagon, stainless steel...	32-56	15.00 ea
B-13406-B	Passenger, black.....	1932	13.50 ea
B-13406-SS	Passenger, stainless steel.....	1932	22.50 ea



A-13406

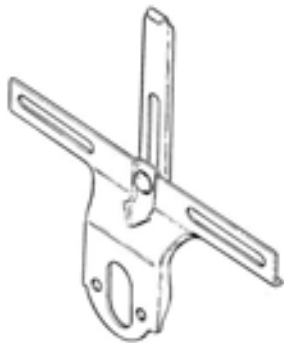

B-13406

REAR LICENSE PLATE BRACKETS continued

40-13406-B	Passenger, black.....	33-36	12.50 ea
40-13406-SS	Passenger, stainless steel.....	33-36	22.00 ea
78-13406-BK	Passenger, black, includes mounting stand.....	1937	20.00 ea

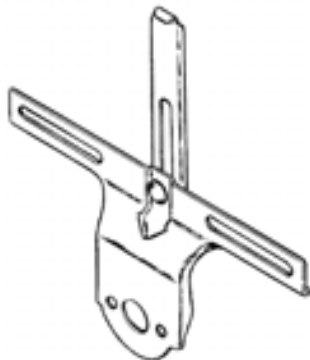

40-13406

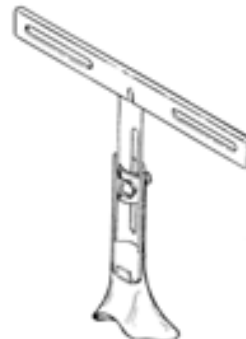

78-13406-BK

01A-13406-B	Passenger, black *.....	38-48	15.00 ea
01A-13406-SS	Passenger, stainless steel *.....	38-48	20.00 ea

***Note: Above license brackets include 81A-13446 pad**

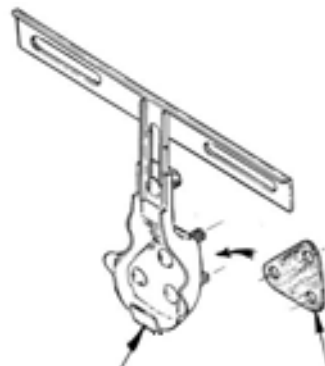

01A-13406

81A-13446

LICENSE PLATE BRACKET PAD

Fits between bracket and trunk lid

81A-13446	Die cut cork, passenger.....	38-48	2.75 ea
-----------	------------------------------	-------	---------

LICENSE PLATE FRAMES

HR-13409	Polished stainless steel, plain.....	40.00 pr
B-13409-32	Die cast chrome, painted blue.....	1932 15.00 pr
18-13409-33	Die cast chrome, painted blue.....	1933 15.00 pr
40-13409-34	Die cast chrome, painted blue.....	1934 NA
48-13409-35	Die cast chrome, painted blue.....	1935 15.00 pr
68-13409-36	Die cast chrome, painted blue.....	1936 NA
78-13409-37	Die cast chrome, painted blue.....	1937 15.00 pr
81A-13409-38	Die cast chrome, painted blue.....	1938 15.00 pr
91A-13409-39	Die cast chrome, painted blue.....	1939 NA
01A-13409-40	Die cast chrome, painted blue.....	1940 NA
11A-13409-41	Die cast chrome, painted blue.....	1941 N/A
21A-13409-42	Die cast chrome, painted blue.....	1942 15.00 pr
51A-13409-46	Die cast chrome, painted blue.....	1946 N/A
51A-13409-47	Die cast chrome, painted blue.....	1947 NA
51A-13409-48	Die cast chrome, painted blue.....	1948 15.00 pr



HR-13409



ROOF SEALS – RUBBER

B-7050920	Roof tack strip seal, all closed cars	32-34	9.00 ea
48-7050920-A	Roof seal, Coupe.....	35-36	25.00 ea
48-7050920-B	Roof seal, Sedan.....	35-36	30.00 ea
48-7050920-C	Roof seal, Sedan delivery.....	35-36	40.00 ea

Roof seal



CLOSED CAR TOP ROOF KITS

Kits are manufactured to original specs using authentic materials available. This includes top material, padding, muslin lining, tacks & sealant. Instructions included with kit. Kits do not include trim welting. Please allow 3-5 weeks for delivery

VTRK/C103B34	Coupes, Colonial grain vinyl ..	32-34	105.00 kit
VTRK/C104B34	Coupes, Cobra short grain vinyl.....	32-34	105.00 kit
VTRK/C113B36	Coupes, Colonial grain vinyl ..	35-36	105.00 kit
VTRK/C114B36	Coupes, Cobra short grain vinyl.....	35-36	105.00 kit
VTRK/C123B34	Sedans, Colonial grain vinyl... ..	32-34	132.00 kit
VTRK/C124B34	Sedans, Cobra short grain vinyl.....	32-34	132.00 kit
VTRK/C133B36	Sedans, Colonial grain vinyl... ..	35-36	132.00 kit
VTRK/C134B36	sedans, Cobra short grain vinyl.....	35-36	132.00 kit



Colonial Grain Vinyl



Cobra Grain Vinyl

REAR WINDOW BUMPERS, ROADSTER

B-42339	Rear window rubber bumper.....	1932	15.00 pr
---------	--------------------------------	------	----------



CONVERTIBLE SEDAN TOP PARTS

78-747048	Convertible top rest, support top when down	37-38	30.00 ea
48-7650548	Quarter to top bow pads, convertible sedan	35-36	10.00 pr
78-711304	Header bow bumper set, screws onto header, 4 pieces	37-40	12.00 set



78-747048



48-7650548



78-711304

01A-7650720	Vacuum "T" line, connects vacuum lines under rear seat ...	1940	10.00 pr
21A-7653382	Top motor to firewall bracket rubber grommet set, 3 pieces...	42-48	15.00 set



01A-7650720



21A-7653382

CONVERTIBLE SEDAN QUARTER TO TOP BOW PADS

78-744858-PR	Quarter to top bow rubber pads, convertible sedan.....	37-38	45.00 pr
78-763244-PR	Quarter to top bow pads, convertible coupe.....	37-39	45.00 pr
91A-744858-PR	Quarter to top bow rubber pads, convertible sedan.....	1939	40.00 pr
01A-6628530-PR	Quarter to top bow rubber pads, convertible.....	1940	45.00 pr

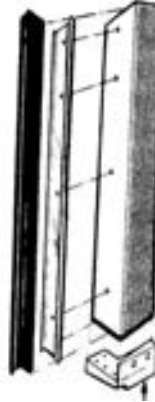

78-763244-PR



78-744858-PR



91A-744858-PR



01A-6628530-PR

CONVERTIBLE PILLAR POST PADS

48-743196-S	Center pillar pads, convertible sedan, 2 upper & 2 lower	35-38	50.00 set
91A-743196-S	Center pillar pads, convertible sedan, 2 upper & 2 lower	1939	50.00 set
48-747162	Convertible top iron rubber pad set, 4 pieces, install where irons fold	35-39	25.00 set

48-747162 Upper pad Lower pad 48-747162

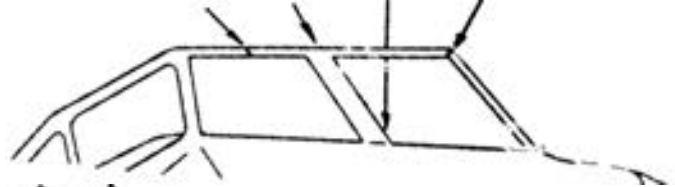

Lower



Upper



48-747162

48-743196-S & 91A-743196-S

SIDE CURTAIN BODY SOCKETS & STUDS

Roadster & Phaeton

A-180620	Side curtain rod socket	30-38	7.00 ea
A-180620-W	Side curtain rod socket washer set of 4, stainless steel	30-38	30.00 set
A-81002	Body socket set, 6 sockets	30-38	36.00 set
A-81002-EA	Body socket as above sold each ..	30-38	6.00 ea
A-81002-T	Body socket installation tool	30-38	4.00 ea



A-180620



A-180620-W



A-81002



A-81002-T

A-42341	Windshield post & curtain studs 12 pieces, 2 long & 10 short	32-35	27.00 set
---------	--	-------	-----------



TOP PROP NUT & THUMB CLAMPING SCREWS

- B-37708-SS Prop nut, Roadster & phaeton, 7/16-14 thread, stainless clad...28-32 6.00 ea
 - B-37472-C Clamping screw, open car, chrome, also fits 1935-193632-34 6.00 ea
 - 48-7650820 Clamping screw, all chrome *... 1935 25.00 ea
 - 68-7650820 Clamping screw, all chrome*.... 1936 20.00 ea
- * Fits convertible sedan & cabriolet, also holds center pillar on convertible sedan.**
- 78-7650820-A Screw for header **, all open cars
Need 3 per car.....37-39 20.00 ea
 - 78-7650820-B Screw for center pillar, ** need
3 per car37-39 20.00 ea
 - 78-7650820-C Screw for slat iron, ** need
2 per car37-39 20.00 ea

*** These screw are brown rubber headed as original**



CONVERTIBLE TOP KNOB

- 01A-7650570 Sand.....1940 12.00 ea
- 11A-7650570 Tan1941 12.00 ea
- 21A-7650570-B Butterscotch.....1942 12.00 ea
- 51A-7650570-C Gray tan with red letters.....1946 12.00 ea
- 6A-7650570 Gray tan with black letters....47-48 12.00 ea



WINDSHIELD LOWER STANCHIONS

- B-37132-S Lower stanchions, roadster & phaeton, includes pads & hardware, die-cast chrome..... 1932 80.00 pr
- 18-37136-SS Upper stanchions, stainless steel with cups & liners, stock height... 1932 115.00 pr
- 18-37136-CHP Upper stanchions as above except chopped 2 inches 1932 125.00 pr
- 40-37136 Upper stanchion, cast brass ready to plate or paint, stock height33-34 ASK
- 40-37136-CHP Upper stanchion as above except chopped 2 inches33-34 ASK

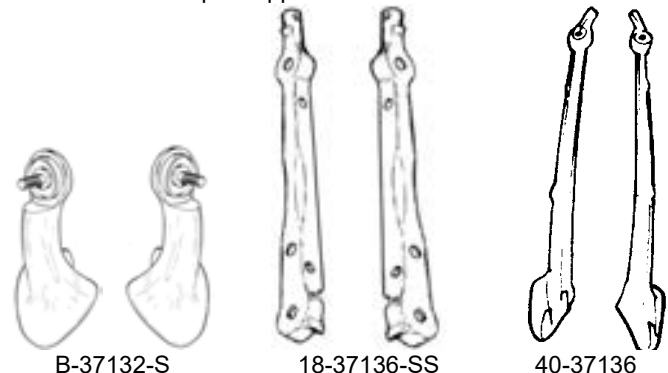

WINDSHIELD STANCHION PADS

Fits between stanchion and body.

- B-37132-PAD Open car, molded rubber 1932 6.00 pr
- 40-711216/7-S Open car, molded rubber 33-34 12.00 pr
- 48-37132-S Open car, molded rubber 35-36 10.00 pr



WIND WING BRACKET SETS

Die cast chrome plated with all hardware & pads included.

- A-18200-B Open car with rubber pads..... 30-35 65.00 set
- A-18200-BPAD Rubber pad set only for above brackets 30-35 4.00 set
- A-18200-C Closed car with straight windshield post w rubber pads. 28-34 65.00 set



WINDSHIELD MISCELLANEOUS PARTS

- 18-37118-S Windshield finger pulls, stainless steel, includes screws..... 32-36 14.00 pr
- B-37158 Windshield frame stud, open car . 16-36 2.50 ea
- 18-37154 Windshield frame cone, roadster and phaeton, chrome plated..... 32-36 6.00 ea
- B-351000 Windshield wing nut, open car, brass & chrome plated..... 32-36 6.00 ea

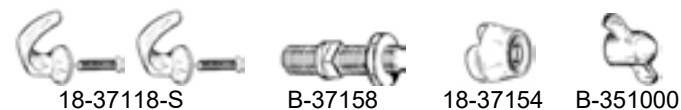

- A-45463-S Windshield slide arms, 1928-1931 passenger & 1928-1934 pickup, chrome plated..... 28-34 12.00 pr
- B-45463-S Windshield slide arms, passenger, chrome plated 1932 19.00 pr



- A-45475-SS Pivot bolt & nut set, 1928-1932 closed car & 1928-1934 pickup, polished stainless steel, 4 piece set..... 28-34 6.00 set
- A-45477-S Slide arm washer set, stainless steel with plastic insert 1928-1932 passenger & 1928-1934 pickup, 4 piece set . 28-34 7.00 set
- B-45482 Slide arm nut, 1928-1932 passenger & 1928-1934 pickup, chrome plated..... 28-34 6.00 ea

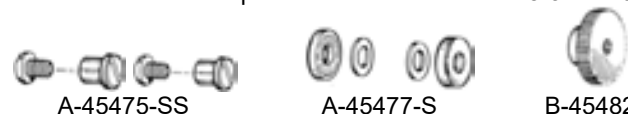

COMPLETE WINDSHIELD FRAMES

		Chrome	Plain steel
B-45400	3 window coupe.....1932	700.00	425.00 ea
B-45405	Closed cars except 3 window coupe.....1932	700.00	425.00 ea
B-37105	Roadster & phaeton.....1932	700.00	425.00 ea
B-761200	Cabriolet.....1932	700.00	425.00 ea
B-78412	Pickup.....32-34	N/A	425.00 ea
40-701200	All closed cars.....33-34	700.00	425.00 ea
40-37105	Roadster & phaeton.....33-34	700.00	425.00 ea
40-761200	Cabriolet.....33-34	700.00	425.00 ea
48-701210	All closed cars.....35-36	700.00	425.00 ea
68-37105	Roadster & phaeton.....35-36	700.00	425.00 ea
48-761200	Cabriolet.....35-36	700.00	425.00 ea
50-701210	Pickup.....35-36	700.00	425.00 ea

All frames include rubber gasket except for 1932-1936 Cabriolet.

Not all frames are in stock, call for availability prior to ordering.



WINDSHIELD REGULATORS

40-701325	Passenger.....33-34	ASK
48-701325	Passenger & pickup.....35-36	ASK



40-701325



48-701325

WINDSHIELD REGULATOR HANDLES & ROLL OUT KNOBS

40-701348	Handle, die cast chrome.....33-34	9.50 ea
48-701348	Handle, die cast chrome.....1935	11.00 ea
68-701348	Handle, die cast chrome.....1936	11.00 ea



40-701348



48-701348



68-701348

78-701348	Handle, die cast chrome.....1937	ASK
81A-701348	Handle, die cast chrome.....1938	ASK
91A-7003120-B	Roll out knob, complete.....1939	50.00 ea
91A-7003120	Roll out knob cover, brown rubber cover that fits over your old chrome knob.....1939	18.00 ea



78-701348



81A-701348



91A-7003120-B



91A-7003120

WINDSHIELD FRAME CORNERS – CHROME PLATED

B-701276-A	5-window coupe & sedan.....1932	9.00 pr
B-701276-B	3-window coupe.....1932	9.00 pr
40-701276-A	All closed cars.....33-34	9.00 pr



B-701276-A



B-701276-B



40-701276-A

WINDSHIELD FRAME JOINT COVERS

48-37112	Closed car & pickup, stainless steel.....35-36	12.00 pr
48-37112-A	Cabriolet & station wagon, stainless steel.....35-36	11.00 pr



WINDSHIELD FRAME SCREW KITS

B-37111-SK	Closed car & pickup, stainless steel, set of 4 screws.....28-34	2.50 set
18-37111-SK	Open car, stainless steel, set of 8 screws.....32-36	3.50 set
48-37111-SK	Closed car & pickup, stainless steel, set of 9 screws.....35-39	4.00 set



48-37111-SK

WINDSHIELD INTERIOR MOLDING & GARNISH CLIP

01A-7003248/9	Interior trim moldings, RH & LH 1940 car & 1940-47 pickup....40-47	175.00 pr
---------------	---	-----------

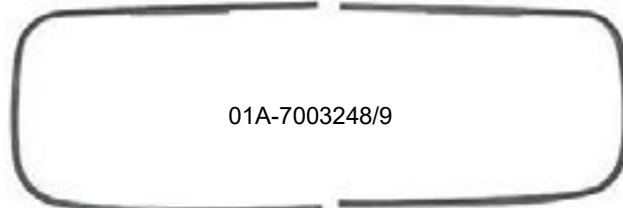

01A-7003248/9

78-701392	Bottom garnish clip, car *.....1937	14.50 ea
81A-701392	Bottom garnish clip, car *.....38-39	14.50 ea
01C-8103092	Top garnish clip, pickup also fits bottom.....40-47	19.00 ea



78-701392



81A-701392



01C-8103092

* Fills the gap between the inside garnish moldings.

WINDSHIELD DIVISION BARS

01A-7003078	1940 closed car & 1940-1947 pickup, outside and inside bar..40-47	38.00 ea
01A-7003074	Inside trim bar only for above...40-47	15.00 ea
11A-7003078-B	All cars, outside bar only, stainless steel.....41-48	50.00 ea



DOOR SILL PLATES 1932 CARS

B-138-1	Roadster & phaeton, stainless steel, 24 3/4"	1932	45.00	pr
B-138-Z	Roadster, zinc	1932	70.00	pr
B-238-1	3-Window coupe, stainless steel..	1932	70.00	pr
B-238-Z	3-Window coupe, stainless steel..	1932	70.00	pr
B-338-1	5-Window coupe & tudor sedan, stainless steel, 34 1/4"	1932	45.00	pr
B-338-Z	5-Window coupe & tudor sedan, zinc	1932	70.00	pr



Typical 1932 Stainless Sill Plate

DOOR SCUFF PLATES 1933-37 CARS

Note: These door scuff plates are not all in stock and subject to availability. Please check stock before ordering.

40-7013250-PR	Tudor sedan, 3-W coupe, and Victoria, front, zinc	33-34	225.00	pr
40-7113250-PR	Roadster & phaeton, front, zinc	33-34	230.00	pr
40-7713250-PR	5-Window coupe & fordor sedan, front, zinc	33-34	225.00	pr
40-7613250-PR	Cabriolet, front, zinc	33-34	250.00	pr
40-7513262-PR	Phaeton, rear, zinc	33-34	300.00	pr
40-7313262-PR	Fordor sedan, rear, zinc	33-34	250.00	pr



1933-34 Typical Front Door Scuff Plates

48-7013250-PR	Tudor sedan, 3-W coupe & cabriolet, front, aluminum	35-36	225.00	pr
48-7713250-PR	5-W coupe, roadster, Phaeton & Fordor sedan, front..	35-36	225.00	pr
48-7413250-PR	Convertible sedan, front, aluminum	35-36	300.00	pr
48-7313262-PR	Fordor sedan & phaeton, rear, aluminum	35-36	ASK	
48-7413262-PR	Convertible sedan, rear, aluminum	35-36	ASK	



1935-36 Typical Front Door Scuff Plates



V8 Detail

78-7013250-PR	Tudor sedan & club coupe, front, aluminum	1937	250.00	pr
78-7113250-PR	Roadster & Cabriolet, aluminum	1937	250.00	pr
78-7313250-PR	5-W coupe, sedan delivery & fordor sedan, front, aluminum	1937	250.00	pr
78-7413250-PR	Phaeton & convertible sedan, front, aluminum	1937	250.00	pr
78-7313262-PR	Fordor sedan, rear, alum	1937	300.00	pr
78-7413262-PR	Phaeton & convertible sedan, rear, aluminum	1937	250.00	pr



1937 Typical Front Door Scuff Plates



V8 detail

DOOR SCUFF PLATES 1938-40 CARS

Rubber seal included

81A-7013250-PR	Tudor & convertible coupe, front, stainless steel	38-39	100.00	pr
81A-7313250-PR	Coupe, sedan delivery & Fordor, front, stainless steel...	38-39	100.00	pr
81A-7413250-PR	1938-39 Convertible sedan and 1938 phaeton, front, stainless steel	38-39	125.00	pr
81A-7413262-PR	Convertible sedan and Phaeton, rear, stainless steel	38-39	125.00	pr
81A-7313262-PR	Fordor sedan, rear, stainless steel	38-39	100.00	pr



1938-39 Typical Front Door Scuff Plates with Lower Door Seal

01A-7013250-PR	Tudor sedan & convertible, front, stainless steel	1940	95.00	pr
01A-7713250-PR	Coupe, sedan delivery & fordor sedan, front, stainless steel	1940	95.00	pr
01A-7313262-PR	Fordor sedan, rear, stainless steel	1940	100.00	pr



1940 Typical Front Door Scuff Plates with Lower Door Seal

DOOR SCUFF PLATES 1941-48 CARS

11A-7013250-PR	Tudor sedan, sedan coupe & convertible, front, stainless steel	41-48	85.00	pr
11A-7713250-PR	Business coupe, sedan delivery & fordor, front, stainless steel	41-48	85.00	pr
11A-7313262-PR	Fordor sedan, rear, stainless steel	41-48	85.00	pr



Door scuff plate

Lower door seal retainer



Lower door rubber seal

LOWER DOOR SEAL RETAINERS CARS & TRUCKS

Rubber seal not included, see next page for door seal

11A-7013224-PR	Tudor except business coupe, aluminum	41-48	85.00	pr
7C-8120712-PR	Pickup 1932-1934 & 1937-1947		12.50	pr
11A-7313224-PR	Fordor sedan & business coupe, front, aluminum	41-48	85.00	pr
11A-7313252-PR	Fordor, rear, aluminum	41-48	85.00	pr

TOP OF DOOR SEALS – CARS

Seals from top of hinge to corner of door opening. Kit does one car.

40-7020532	1932 3-window Coupe,		
	1933-1934 Coupe and tudor	32-34	10.00 kit
40-7320532	Fordor sedan	33-34	15.00 kit
48-7020532	Coupe and Tudor sedan	35-36	10.00 kit
48-7320532	Fordor sedan	35-36	15.00 kit
78-7020532	Coupe & Tudor sedan	37-48	10.00 kit
78-7320532	Fordor sedan, 12 ft length	37-48	15.00 kit
99A-7020532	Mercury coupe, 18 ft	39-40	50.00 kit



DOOR HINGE SEALS – CARS

Seals from top of hinge to bottom corner of door. High quality molded sponge rubber. Molded to fit around hinges.

48-701884/5	All body styles *	35-36	16.00 pr
78-701884/5	All closed cars *	1937	16.00 pr
78-701884/5-C	Convertible	37-40	16.00 pr
81A-701884/5	Closed cars	38-40	16.00 pr
11A-701884/5	Closed cars	41-48	16.00 pr
11A-701884/5-C	Convertibles	41-48	16.00 pr

* Kit does 2 doors, for Fordor models a 2nd kit can be used but must be cut for installation at hinge side of rear door.

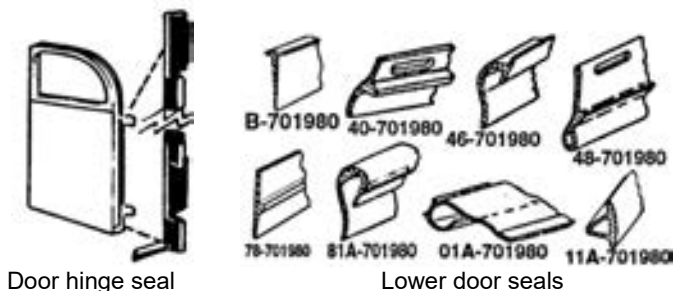

LOWER DOOR SEALS – CARS

Made of high quality rubber. Each style is exactly like original. Slots are punched on styles that require them for mounting clips. Kit does all doors for body type listed

B-701980	Roadster & Phaeton	1932	8.00 kit
40-701980	1932-34 Coupe & Tudor & 1933-34 Roadster	32-34	15.00 kit
40-701980-F	Fordor	32-34	20.00 kit
48-701980	Coupe, Roadster & Tudor	35-36	15.00 kit
48-701980-F	Fordor & touring	35-36	20.00 kit
78-701980	Coupe & Tudor	1937	15.00 kit
78-701980-F	Fordor sedan and touring	1937	20.00 kit
81A-701980	Coupe and Tudor sedan	38-39	12.00 kit
81A-701980-F	Fordor sedan and Convertible sedan	38-39	18.00 kit
01A-701980	Coupe and Tudor sedan	1940	12.00 kit
01A-701980-F	Fordor sedan	1940	18.00 kit
11A-701980	Coupe, convertible coupe and Tudor sedan	41-48	12.00 kit
11A-701980-F	Fordor sedan	41-48	18.00 kit

LOWER DOOR SEALS – PICKUPS

46-701980	Pickup	32-34	9.00 kit
48-701980	Pickup	35-36	14.00 kit
46-701980	Pickup	37-47	9.00 kit

The only door seal originally used on the 1932-1947 pickups was the lower door seal. To add a seal to front, top and back side of door use seal listed below. One kit does one door.

78-7320532	Pickup, 12 ft length	32-47	15.00 kit
------------	----------------------	-------	-----------



BACK OF DOOR SEALS, 1941 – 1948 - CARS

Extruded sponge rubber fits left hand or right hand side.

Kit does one car.

11A-7020546	Tudor, coupe	41-48	7.00 kit
11A-7320546	Fordor	41-48	20.00 kit
11A-7620546	Convertible	41-48	12.00 kit
11A-7020548	Lower back of corner seal	41-48	13.00 pr



11A-7020548

DOOR SEALS – STATION WAGON

81A-791980	Lower door seal kit for all 4 doors	38-39	35.00 kit
21A-791980	Kit for top and sides of all 4 doors, (seal for bottom of door sold separately)	40-48	55.00 kit

WEATHERSTRIP ADHESIVE

Black color. Use for door seals, trunk seals etc.

M-500	5.0 ounce tube	10.00 ea
-------	----------------	----------



DOOR SEALS - NON ORIGINAL

An alternative to the above original style seals. These are sponge rubber with pressure sensitive adhesive on back.

Rectangular shape, solid sponge rubber with ribbed surface
 HR-701980-S 3/8" wide x 3/16 high" x 20' roll 15.00 roll
 HR-701980-L 5/8" wide x 3/8 high" x 20' roll 20.00 roll

Half round shape, hollow core sponge rubber, smooth surface
 SR-701980-S 3/8" wide x 3/16 high" x 20' roll 15.00 roll
 SR-701980-L 5/8" wide x 3/8 high" x 20' roll 20.00 roll



DOOR LOCK CYLINDERS

- B-7121984 Replacement type with 2 keys...32-48 14.00 ea
- B-7121984-PR Same as above, but pair with matching keys32-48 25.00 pr



B-7121984

- 48-702302 Authentic reproduction with 2 keys. Flipper has indented circle with raised notch35-41 35.00 ea

- 21A-702302 Authentic reproduction with 2 keys. Flipper has raised teardrop notch42-48 35.00 ea



48-702302
for key access

Flipper shown moved



21A-702302

Note: Shaft length on locks may have to be cut to suit, either of these fit 1932-1948. Available in pairs keyed alike by request.

DOOR HINGE PINS

Plain steel standard size (as original) with oil groove.

- B-7022840 2 1/2" long x .28 diameter..... 32-48 3.00 ea
- B-7022840-L 2 3/4" long x .28 diameter (for use with hinge pin mirror) 32-48 3.00 ea

Plain steel oversized for worn holes with NO oil groove

- 48-702475-OSA 2 1/2" long x .344" diameter..... 32-48 4.00 ea

Stainless steel standard size with NO oil groove

- 50-46335-SS 2 1/2" lg x.28" diameter,..... 32-48 4.00 ea
- B-46335-SS 2 3/4" long x .28 diameter (for use with hinge pin mirror) 32-48 4.00 ea

Stainless steel oversized for worn holes with NO oil groove

- 48-702475-OS 2 1/2" long x .344" diameter 32-48 5.00 ea
- B-46335-OSS 2 3/4" long x .344" diameter..... 32-48 N/A



Hinge pin with oil groove



Hinge pin without oil groove

HINGE PIN PULLER

Made of forged steel with a heat treated bolt, (4) hardened steel extensions pins included.

- TL-100 Hinge pin puller with extension pins.....25.00 ea
- TL-100-P Spare set of extension pins for puller.....5.00 ea



Hinge pin puller



Extension pins

INSIDE DOOR PULLS

- 40-702420-A Inside door pull handles, chrome 1933 45.00 pr
- 40-702420-B Inside door pull straps with brackets.....34-35 35.00 pr



40-702420-A



40-702420-B

DOOR ARM REST KITS

Kits for both doors include rest brackets, mounting clips, pads and installation hardware. Just add upholstery!

- A-56665-PR Front arm rest kit, original style, cars..... 32-48 85.00 kit
- A-56666-PR Rear arm rest kit, all sedans and Victoria, original style 28-34 115.00 kit
- HR-56666-PR Front arm rest kit, custom style with hand pull socket, cars "Baby size"..... 32-48 140.00 kit
- HR-56665-PR Front arm rest kit, custom style with hand pull socket, cars "Daddy size"..... 32-48 140.00 kit



A-56665-PR

HR-56665-PR



HR-56666-PR



HR-56665-PR

DOOR HINGE SCREW & NUT KITS

- A-46300-ASW 5/16"-24 x 7/8", door hinge screws, kit has 3 screws and 3 recessed washers, all styles except 3-window coupe, will fit hinges of many 1935-1936 pickups..... 32-34 2.50 kit
- B-80006-B 5/16"-24 x 3", door hinge screws, 3-window coupe 32-34 1.00 ea
- B-80006-C 5/16"-18 x 2", door hinge screws, closed car, 3 screws, nuts & washers per kit..... 35-36 2.25 kit



A-46300-ASW



B-80006-B



B-80006-C

- B-80006-D 5/16"-24 x 1", door hinge screws, oval head, 37-40 closed car & 42-47 pickups 3 screws & 3 nuts per kit..... 37-47 2.50 kit
- B-803116-C 5/16"-24 x 1 3/4", 3 screws and 3 nuts per kit, pickups 37-41 3.00 kit
- A-80033-W Recessed washer30 ea
- B-801166-C 5/16"-24, hinge screw T-nut 32-34 2.50 ea



B-80006-D



B-803116-C



A-80033-W



B-801166-C

DOOR CHECK KITS

A-702828-S	Door check strap kit, roadster and phaeton, light brown leather straps with stainless steel brackets & screws, 8 1/2" long, enough for two doors.....	1932	26.00	kit
B-702828-S	Door check arm kit, coupes and sedans, cadmium plated steel with rubber bumpers, 1932-47 pickups, 1935-48 cars	32-48	6.00	pr
81A-702828-SS	Door check arm kit as above except stainless steel	38-48	30.00	pr
B-7023501	Door check arm rubber bumper only.....	32-48	1.00	ea

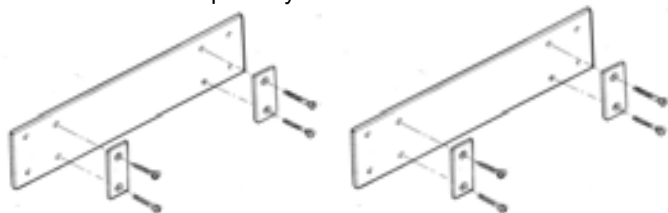

A-702828-S

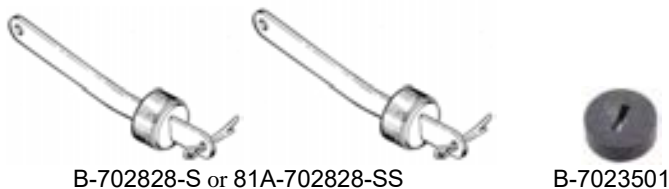

B-702828-S or 81A-702828-SS

B-7023501

DOOR CHECK STRAPS – "T" TYPE

B-162592-LT	Black reinforced rubber, 3W coupe, 33-34 closed cars ...	32-34	6.00	ea
B-162592-S	Adjustable bracket for above door check strap.....	32-34	3.75	ea



B-162592-LT

B-162592-S

DOOR CHECK STRAPS – REINFORCED RUBBER LOOP TYPE - STATION WAGON

B-162592-L6	6 1/4" Black rubber,	32-48	5.00	ea
B-162592-L7	7 1/4" Black rubber,	32-48	5.00	ea
B-162592-L8	8 1/4" Black rubber	32-48	5.00	ea
78-794400	5 1/8" Brown rubber.....	32-48	25.00	pr
B-151587	6 1/8" Brown rubber.....	32-48	25.00	pr
11A-7923504	7 1/8" Brown rubber.....	32-48	25.00	pr
B-42150-B	Door check strap bracket for above, chrome.....	32-48	3.00	ea

Note: Hole centers for door check straps are 1/2" shorter than lengths specified above.



Typical door check strap-Loop type

B-42150-B

DOVETAILS – FEMALE

18-35576-BS	Roadster & phaeton, black.....	32-36	ASK
18-35576-SS	Roadster & phaeton, stainless steel	32-36	35.00 pr
B-35576-BS	Closed car, cabriolet & pickup, black	1932	30.00 pr
B-35576-SS	Closed car, cabriolet & pickup, stainless steel	1932	35.00 pr
40-35576-BS	Closed car, cabriolet & pickup, black	33-34	30.00 pr
40-35576-SS	Closed car, cabriolet & pickup, stainless steel	33-34	35.00 pr
78-35576	Passenger, cadmium plated.....	37-40	20.00 pr
11A-702570	Passenger, cadmium plated.....	41-48	20.00 pr



B-35576 40-35576 18-35576 78-35576 11A-702570

B-702574-RK	Repair kit, passenger & pickup, 2 springs & 2 wedges.....	32-34	6.00	kit
48-702574-RK	Repair kit, 1935-1940 passenger & 1935-1941 pickup, 2 springs & 2 wedges.....	35-41	6.00	kit
11A-702574-RK	Repair kit, 1941-1948 passenger & 1942-1952 pickup, 2 springs & 2 wedges.....	41-48	6.00	kit



B-702574-RK

48-702574-RK

11A-702574-RK

DOVETAILS – MALE

A-76819-A	Roadster pickup, stainless steel	28-34	3.00	ea
B-35582	Roadster	1932	10.00	ea
B-46421-A	1932 closed car & 1932-1934 pickup also 1931 slant windshield Fordor.....	30-34	11.00	ea
40-35577-ASS	1933-1934 closed car and 1935-1941 pickup, stainless Steel	32-41	10.00	ea
40-35577-BSS	Roadster & phaeton, stainless steel, stamped by Vintique.....	33-36	7.00	ea
40-712018	Same as 40-35577-BSS except solid stainless steel by Drake....	33-36	10.00	ea
48-702550-A	Closed car.....	35-40	10.00	ea
11A-35577-ASS	1941-1948 passenger and 1942-1952 pickup, stainless steel	41-52	10.00	ea



B-46421-A

40-35577-BSS
A-76819-A

40-35577-ASS
48-702550-A

11A-35577-ASS

DOOR WINDOW ROLLER KIT 1939-1940 CONVERTIBLE

01A-6622218-K Set of 4 roller assemblies.....39-40 80.00 kit



TUBE NUT KIT

For 1932 closed car & 1942-47 pickup door window frames

A-48222 10 sets of male/female pairs 5.50 kit



DOOR GLASS BUMPERS

B-46044 Snaps on door frame32-36 .25 ea
 B-45830 Snaps on garnish molding.....32-35 .25 ea
 48-7821444 Garnish molding bumper, cabriolet & convertible, 5" long....32-35 4.00 ea
 A-48141 Window cushion stop, rubber, fits inside doors or rear quarter window at bottom32-34 1.00 ea



B-46044



B-45830



A-48141



48-7821444

RUBBER DOOR BUMPERS

B-46440 1932-1936 passenger and 1932-1952 pickup.....32-52 1.50 ea
 B-191442-B 1932 Victoria, B-400, 1932 and 1934 sedan delivery and 1935-1936 convertible sedan...32-36 2.50 ea
 B-151444 Station wagon and convertible sedan.....32-39 3.50 ea
 78-702610 Passenger37-48 1.50 ea



B-46440



B-191442-B



B-151444



78-702610

01A-702610 Door catch bumper kit, convertible, 8 pieces..... 1940 5.00 kit
 11A-7023030-B Coupe & sedan, fits in upper corner41-48 3.00 pr



01A-702610



11A-7023030-B

TAILGATE BUMPERS

91A-7943916 Station wagon tailgate bumpers39-41 20.00 pr
 21A-7943916 Station wagon tailgate bumpers42-48 20.00 pr

DOOR STRIKER PLATES & PARTS

B-702340-SS Striker plate, 3-window coupe, stainless steel 1932 12.00 ea
 B-35705 Striker plate, roadster and phaeton, plain steel 1932 ASK
 B-35705-SS Striker plate, roadster and phaeton, stainless steel 1932 18.00 ea
 40-702340 Striker plate, closed car and pickup, plain steel * 32-34 6.50 ea
 40-702340-SS Striker plate, closed car and pickup, stainless steel * 32-34 10.00 ea
 40-702336 Striker plate mounting plate, .81" hole center distance 32-39 15.00 ea
 48-702336-A Striker plate mounting plate, .70" hole center distance 33-56 15.00 ea



B-702340



B-35705



40-702340



40-702336
48-702336-A

** Note: Either 40-702340 or 81A-702340 could have been used on 1935 cars or trucks. Compare your old one to illustration.*

40-711830-B-SS Striker plate, roadster and phaeton, stainless steel 33-36 20.00 ea
 81A-702340 Striker plate, 1935-1939 passenger and 1935-1947 pickup, plain steel * 35-47 8.50 ea
 81A-702340-SS Striker plate, 1935-1939 passenger and 1935-1947 pickup, stainless steel * 35-47 12.00 ea
 78-7022026 Plate pads, all closed cars, rubber 37-38 3.75 pr
 91A-7622010 Striker plate, convertible, plain steel 39-40 25.00 ea
 91A-7622010-S Striker plate, convertible, stainless steel 39-40 30.00 ea



40-711830



81A-702340



78-7022026



91A-7622010

01A-7022008 Striker plate, 1940 closed car, and 1941-1948 station wagon, plain steel..... 1940 20.00 ea
 01A-7022008-C Striker plate, 1940 closed car, and 1941-1948 station wagon, stainless steel 1940 25.00 ea
 01A-7022026 Plate pads, passenger, rubber 1940 3.75 pr
 11A-702340 Striker plate, passenger, chrome plated 41-48 11.00 ea
 11A-7022026 Plate pads, passenger, rubber 41-48 3.75 pr



01A-7022008



11A-702340



11A-7022026



7C-8122010

DOOR LATCHES

- B-46105-5W Latch assembly, car, LH 1932 195.00 ea
 - B-46106-5W Latch assembly, car, RH..... 1932 195.00 ea
 - B-46105-PU Latch assembly, pickup, LH.. 32-34 195.00 ea
 - B-46106-PU Latch assembly, pickup, RH .32-34 195.00 ea
- Note: Above includes linkage arms



Typical latch assembly (B-46105-PU shown)

- 50-811850/1 Latch assembly, RH & LH, with linkage arms, pickups35-37 240.00 pr



50-811850/1

- 81C-811850/1 Latch assembly, RH & LH, with linkage arms, pickups ...38-47 ASK



81C-811850/1

- 01A-7021812/3 Latch assemblies only, RH & LH, closed car only.....37-40 150.00 set

- 01A-7021812/3-K Latch assemblies as above with parts to add keylock to driver side door37-40 ASK



01A-7021812/3

- 81A-732412/3 Linkage RH & LH, die stamped steel linkage arms, coupes, Fordor & sedan delivery.....38-40 ASK

- 81A-732412/3-NA RH & LH Pivot mounts less latch arms with connection hardware.....37-40 40.00 pr



81A-732412/3

81A-732412/3-NA

DOOR LATCHES continued

- 01A-6621800/1 Latch assembly only RH & LH 1935-39 Conv sedan Front & 1937 Roadster & Phaeton front & rear, 1938-40 all convertibles 35-40 210.00 pr
- 01A-6621800/1-K Latch assemblies as above with parts to add keylock to driver side door..... 37-40 ASK



01A-6621800/1

REMOTE SPRING FOR INSIDE DOOR HANDLE

Spring that controls the inside door handle lock "detent" position.

- B-702268 All doors 32-40 3.75 ea
- 11A-702268 All doors 41-48 6.00 ea



B-702268



11A-702268

DOOR LATCH SPRINGS

- B-702267 All doors, black..... 1932 7.00 ea
- 40-702267 All doors, green..... 33-34 5.00 ea
- 68-702267 All doors, yellow, 1935-early 1936..... 35-36 6.00 ea



B-702267



40-702267



68-702267

- 78-702267 All doors, brown, late 1936-1937 36-37 6.00 ea
- 81A-702267 All doors, light blue..... 38-40 6.00 ea
- 81A-702267-A All doors, white..... 38-40 6.00 ea



78-702267



81A-702267



81A-702267-A

- 11A-702267 All doors, dark blue 41-48 4.75 ea
- 11A-702267-A All doors, red..... 41-48 4.75 ea



11A-702267



11A-702267-A

WINDOW REGULATORS-DOORS

Note: Only RH regulators shown below

18-702700	RH, coupe & sedan.....	1933	65.00	ea
18-702701	LH, coupe & sedan	1933	65.00	ea
40-702700	RH front door, 1934 coupe and sedan, LH rear quarter, 1935-1936 tudor.....	34-36	135.00	ea
40-702701	LH front door, 1934 coupe and sedan, RH rear quarter, 1935-1936 tudor.....	34-36	135.00	ea
40-702700/1	Pair of RH & LH regulators as as above SAVE.....	34-36	225.00	pr



18-702700



40-702700

50-812700/1	Pickup, RH & LH.....	35-37	165.00	pr
-------------	----------------------	-------	--------	----



50-812700/1

81C-812700/1	Pickup, RH & LH.....	38-47	ASK	
--------------	----------------------	-------	-----	--



81C-812700/1

01A-7323200/1	Coupe, Fordor, Sedan Delivery RH & LH.....	1940	175.00	pr
01A-7023200/1	Tudor, RH & LH.....	1940	175.00	pr
01A-6623200/1	Convertible	1940	250.00	pr



01A-7323200

WINDOW REGULATOR HARDWARE

78-702148-K	Window regulator channel studs. Fits in roll down door & quarter window regulator channel that holds glass and connects to window regulator arms, set of (2) .	35-48	16.00	pr
01A-7023200-HK	Window regulator to door mounting hardware kit, 12-24 threaded screws 32 pieces, does 2 regulators	35-48	11.50	kit



78-702148-K



01A-7023200-HK

WINDOW REGULATOR REPAIR PARTS

A-48105-RK	Small gear repair kit, 6 tooth	28-34	15.00	kit
WRK-48105-B	Small gear repair kit, 10 tooth ..	32-34	30.00	kit
WRK-48105-C	Small gear repair kit, 6 tooth	35-39	30.00	kit
WRK-48105-D	Small gear repair kit, 6 tooth	40-48	30.00	kit
A-48105/6-S	Window regulator replacement spring	32-48	6.50	ea



A-48105-RK



A-48105/6-S

WINDOW REGULATORS-REAR WINDOW

For bodies that have a rear window that rolls up & down.

A-48105-B	Passenger, 4 mounting holes *	30-36	40.00	ea
-----------	------------------------------------	-------	-------	----



* Note: This regulator may not fit some 1935-36 models-compare your regulator to above photo

REAR WINDOW REGULATOR HANDLES

A-164272-BRC	Use also for Fordor quarter window, die cast chrome.....	1932	11.00	ea
40-724470	1933-1934 coupe & for Fordor quarter window, also fits 1935-36 coupe, die cast chrome.....	33-36	11.00	ea



A-164272-BRC



40-724470

INSIDE DOOR HANDLES

18-702400-A	Roadster & Phaeton, chrome RH & LH.....	1932	45.00 pr
B-702400-E	Closed car, chrome	1932	10.00 ea
46-702400-E	Pickup, chrome	32-34	10.00 ea



18-702400-A B-702400-E 46-702400-E

40-702400-E	Closed car, chrome	33-34	10.00 ea
A-702400-C	1933-34 Roadster & phaeton, chrome , also fits 28-31 Roadster 32-56 panel & 32-34 wagon	33-34	10.00 ea



40-702400 A-702400-C

48-702400-E	Closed car & pickup, chrome ...	1935	10.00 ea
48-702400-G	Deluxe, gray paint	1935	N/A
48-7622600-B	Roadster & Phaeton, Butler finish	1935	30.00 ea



48-702400 48-7622600-B

68-702400-E	1936 closed car, chrome	1936	10.00 ea
68-702400-E	Pickup, chrome	36-37	10.00 ea
68-702400-G	Deluxe (early), gray paint	1936	10.00 ea
68-702400-M	Deluxe (late), mahogany paint ...	1936	N/A
68-7622600-C	Roadster & Phaeton, chrome ..	1936	30.00 ea



68-702400 68-7622600-C

78-7022600-A	Cars, chrome	1937	12.00 ea
78-7022600-B	Deluxe car, brown paint	1937	17.00 ea
81A-7022600-A	Cars, chrome	1938	15.00 ea
81A-7022600-B	Deluxe car, brown paint	1938	17.00 ea
81C-8122600	Pickup, chrome	38-47	14.00 ea



78-7022600 81A-7022600 81C-8122600

91A-7022600-A	1939 All car, 1940 Standard, chrome	39-40	12.00 ea
91A-7022600-B	Deluxe car, brown paint	1939	17.00 ea
01A-702400	Deluxe car, chrome	1940	10.00 ea
01A-7022600-B	Deluxe car, brown paint	1940	15.00 ea



91A-7022600 01A-702400

11A-702400	All cars, chrome	41-48	10.00 ea
7C-8122614	Pickup, chrome	48-52	12.00 ea



11A-702400 7C-8122614

WINDOW CRANKS

B-702780-E	Closed car, chrome *	1932	11.00 ea
40-702780-E	Closed car, chrome *	33-34	13.00 ea
B-7023345	Window crank brown marble knob with pin *.....	32-34	6.00 ea

***For customer wanting brown knob, B-7023345 offered for customer to change onto B-702780-E & 40-702780-E cranks**



B-702780 40-702780-E B-7023345

46-702780-E	Pickup, chrome	32-34	11.00 ea
48-702780-E	Closed car & pickup, chrome ...	1935	11.00 ea
48-702780-G	Deluxe car, dark gray, with light gray knob	1935	15.00 ea
68-702780-E	Closed car, chrome	1936	11.00 ea
68-702780-E	Pickup, chrome	36-37	11.00 ea
68-702780-G	Deluxe car (early), dark gray with light gray knob	1936	15.00 ea
68-702780-M	Deluxe car (late), dark brown with mahogany knob	1936	N/A



46-702780 48-702780 68-702780

78-702780	Car, chrome	1937	15.00 ea
78-7023342-A	Standard car, chrome, with light brown knob	1937	20.00 ea
78-7023342-B	Deluxe car, brown, with yellowish brown knob	1937	20.00 ea
81A-7023342-D	Car, all chrome	1938	15.00 ea
81A-7023342-A	Car, chrome with ivory knob	1938	20.00 ea
81A-7023342-B	Deluxe car, brown with ivory knob	1938	20.00 ea
81C-7023342	Pickup, all chrome	38-40	20.00 ea

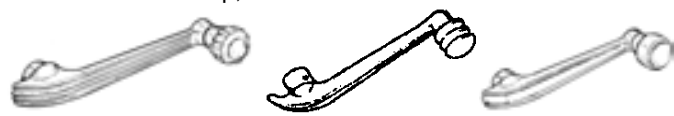

78-702780 81A-7023342 81C-7023342
78-7023342

91A-7023342-D	Car, standard, all chrome	1939	15.00 ea
91A-7023342-A	Standard car, chrome with light yellow knob	1939	20.00 ea
91A-7023342-B	Deluxe car, brown with light yellow knob	1939	20.00 ea
01A-7023342-A	Standard car, chrome with sand knob	1940	20.00 ea
01A-7023342-B	Deluxe car, brown with sand knob	1940	20.00 ea
01A-702780	Deluxe car, all chrome	1940	11.50 ea
01A-70223342-C	Deluxe car, chrome with sand knob	1940	20.00 ea



91A-7023342 01A-7023342-B & -C
01A-702780

WINDOW CRANKS continued

11A-702780	Car, all chrome	41-48	11.50 ea
11A-7023342	Car, chrome with tan knob	1941	20.00 ea
11C-7023342	Pickup, chrome with black knob	41-47	20.00 ea
21A-7023342-A	Special, chrome with maroon knob	1942	20.00 ea
21A-7023342-B	Deluxe, super deluxe, closed car, convertible & station wagon, chrome with butterscotch knob	1942	20.00 ea
51A-7023342-A	Deluxe, chrome with chocolate knob	1946	20.00 ea
51A-7023342-B	Super deluxe, chrome with blue gray knob	1946	20.00 ea
51A-7023342-C	1947-1948 passenger, and 1946 convertible, station wagon, and sportsman, chrome with grayish tan knob	46-48	20.00 ea



11A-702780 11A-7023342
21A-7023342 51A-7023342



11C-7023342

7C-8123342	Pickup, chrome with black knob ...	48-52	15.00 ea
------------	------------------------------------	-------	----------



7C-8123342

DOOR HANDLE & WINDOW CRANK ESCUTCHEONS

B-48139-A	Universal type, spring loaded, chrome, 1 7/8" outer, 1 1/16" inner stainless steel	32-48	4.50 ea
B-48139-AS	Closed car, stainless steel	1932	5.00 ea
A-46270-AS	Open car, includes backing plate, chrome	31-32	7.00 pr
46-48139-AS	Pickup, stainless steel	32-34	5.00 ea



B-48139-A



B-48139-AS



A-46270-AS



46-48139-AS

40-48139-BC	Open car, chrome	33-34	5.00 ea
40-48139-AS	Closed car, stainless steel	33-34	5.00 ea
68-48139-BC	Open car, chrome plated	35-36	6.00 ea
48-48139-AS	1935-1936 Closed car, stainless steel	35-36	5.00 ea
48-7022618	Closed car, deluxe, gray plastic	1935	5.00 ea
68-7022618-B	Closed car, deluxe, (early), gray plastic	1936	5.00 ea
68-7022618-C	Closed car, deluxe, (late), mahogany plastic	1936	5.00 ea
48-48139-AS	Pickup, stainless steel	35-37	5.00 ea



40-48139-BC



40-48139-AS



48-48139-AS
48-7022618
68-7022618



68-48139-BC

DOOR HANDLE & WINDOW CRANK ESCUTCHEONS continued

78-48139-SS	All cars, stainless steel	1937	7.50 ea
78-7022618-A	Standard, light brown plastic	1937	5.00 ea
78-7022618-B	Deluxe, yellow brown plastic	1937	5.00 ea
91A-48139-SS	All cars, stainless steel	38-39	5.00 ea
91C-48139-SS	Pickup, spring loaded, stainless steel	38-47	8.00 ea
81A-7022618	All cars, ivory plastic	1938	5.00 ea
91A-7022618	All cars, light yellow plastic ...	1939	5.00 ea



78-48139-SS
78-7022618



91A-48139-SS
81A-7022618
91A-7022618



91C-48139-SS

91A-48139-SS	Standard, stainless steel	38-40	5.00 ea
01A-7022618-A	Standard, sand plastic	1940	5.00 ea
01A-48139-SS	Deluxe cars, stainless steel	1940	6.00 ea
01A-7022618-B	Deluxe, sand plastic	1940	5.00 ea



91A-48139-SS
01A-7022618-A



01A-48139-SS
01A-7022618-B

11A-48139-SS	All cars, all stainless steel	41-48	8.00 ea
11A-7022618	All cars, tan plastic *.....	1941	10.00 ea
21A-7022618-A	Special, maroon plastic *.....	1942	10.00 ea
21A-7022618-B	Deluxe & super deluxe, butterscotch plastic *.....	1942	10.00 ea
51A-7022618-A	Deluxe, chocolate plastic	1946	10.00 ea
51A-7022618-B	Super deluxe, blue gray plastic *.....	1946	10.00 ea
51A-7022618-C	1946-1948 All cars, grayish tan plastic *.....	46-48	10.00 ea

* Note: 1941-1948 spring loaded 2 piece style, plastic & metal center.

7C-48139-SS	Pickup, spring loaded, stainless steel	48-52	8.00 ea
A-48284	Escutcheon spring.....	28-52	1.00 ea



11A-48139-SS 11A-7022618
21A-7022618 51A-7022618



7C-48139-SS



A-48284

RETAINER PINS to hold inside handles & cranks

A-46250-P	9/16" long, 1932-1948 except 1940 Deluxe cars.....	.20 ea
01A-46250-P	13/16" long, 1940 cars only.....	.50 ea



A-46250-P



01A-46250-P

ESCUTCHEON TOOL

Depresses Escutcheons to Expose Fastener Pins Securing Window Crank or Door Handle

TL-111	Rubber cover ends.....	15.00 ea
--------	------------------------	----------



DOOR LOCK ESCUTCHEONS & PADS

68-7622012	Escutcheon, chrome, roadster and phaeton	1936	25.00 ea
78-7622012-PR	Escutcheon, convertible, chrome, set of 2 with screws & sleeve nuts.....	37-40	40.00 pr
11A-7923465-K	Pad, station wagon, 8 pieces.....	41-48	20.00 kit



68-7622012



78-7622012-PR



11A-7923465-K

VENT WINDOW LEVER PARTS

01A-7022938	Vent window lever bracket repair kit, 1940 & 1947-1948 passenger & Mercury, stainless steel with rivets, does one window	40-48	15.00 kit
11A-7023402-GR	Vent window gear repair kit, gear, spring, 4 rivets and instructions.....	41-48	34.00 kit



01A-7022938



11A-7023402-GR

VENT WINDOW CRANKS

11A-7023410	With light tan knob	1941	20.00 ea
21A-7023410-A	With maroon knob.....	1942	20.00 ea
21A-7023410-B	With butterscotch knob	1942	20.00 ea
51A-7023410-A	With chocolate knob.....	1946	20.00 ea
51A-7023410-B	With blue gray knob	1946	20.00 ea
51A-7023410-C	With gray tan knob.....	46-48	20.00ea
51A-7023410-CC	With chrome knob.....	41-48	15.00 ea



VENT WINDOW PLASTIC ESCUTCHEONS

11A-7023404	Tan.....	1941	5.00 ea
21A-7023404-A	Special, maroon.....	1942	6.00 ea
21A-7023404-B	Deluxe and super deluxe, butterscotch	1942	6.00 ea
51A-7023404-A	Deluxe, chocolate	1946	6.00 ea
51A-7023404-B	Blue gray.....	1946	6.00 ea
51A-7023404-C	Gray tan.....	46-48	6.00 ea



VENT WINDOW LEVERS

Die cast and chrome plated. Each pair includes the buttons and all hardware. Kit does both windows.

01A-7022916/7	Passenger, 12 pieces	40-48	55.00 kit
---------------	----------------------------	-------	-----------



QUARTER WINDOW CRANKS -STATION WAGON

11A-7923410	With light tan knob	1941	22.00 ea
21A-7923410-A	With maroon knob	1942	22.00 ea
21A-7923410-B	With butterscotch knob	1942	22.00 ea
51A-7923410-A	With chocolate knob	1946	22.00 ea
51A-7923410-B	With blue gray knob.....	1946	22.00 ea
51A-7923410-C	With gray tan knob	46-48	22.00 ea
51A-7923410-CC	With chrome knob	41-48	22.00 ea

Uses matching spring loaded escutcheons for window cranks and door handles on previous page.



DOOR LOCK TWIST KNOB

A-46192-B	Chrome plated with screw, closed cars	32-34	6.00 ea
-----------	---	-------	---------



DOOR HANDLE CONTROL RODS

Link the inside door handles with door latches.

18-702401-R	Roadster and phaeton only	1932	7.00 pr
-------------	---------------------------------	------	---------



WINDOW CRANK KNOBS

B-7023345	Brown marble.....	32-34	6.00 ea
48-7023345-B	Ivory, Deluxe	1935	6.00 ea
68-7023345-B	Gray, Early Deluxe	1936	6.00 ea
68-7023345-C	Red brown, Late deluxe	1936	6.00 ea
78-7023345-A	Light brown, standard	1937	7.00 ea
78-7023345-B	Yellow brown, Deluxe	1937	7.00 ea



B-7023345



48-7023345



68-7023345-B



78-7023345-A

81A-7023345	Ivory	1938	6.00 ea
91A-7023345	Light yellow	1939	6.00 ea
99A-7023345	Mercury, pink	1939	7.00 ea
01A-7023345-A	Sand, Standard	1940	6.00 ea
01A-7023345-B	Sand, Deluxe	1940	6.00 ea



81A-7023345



91A-7023345



01A-7023345-A



01A-7023345-B

09A-7023345	Mercury, dark blue.....	1940	6.00 ea
11A-7023345	Light tan.....	1941	6.00 ea
21A-7023345-A	Maroon	1942	7.00 ea
21A-7023345-B	Butterscotch	1942	7.00 ea
51A-7023345-A	Chocolate	1946	7.00 ea
51A-7023345-B	Blue gray	1946	6.00 ea
51A-7023345-C	Grayish tan.....	46-48	6.00 ea



11A-7023345



51A-7023345-C

OUTSIDE DOOR HANDLES

DIE CAST & CHROME PLATED EXCEPT AS NOTED

A-702350-O	Roadster & phaeton, also fits 1934 open car, but is not original.....	28-33	25.00 ea
B-702350	Closed car except 3-window coupe & cabriolet, RH, (curved base) (chrome).....	1932	28.00 ea
B-702351	Closed car except 3-window coupe & cabriolet, LH, (curved base) (chrome).....	1932	28.00 ea
B-702350/1	Same as above except stainless steel, RH & LH (pairs only).....	1932	120.00 pr
40-702350	1932 3-window coupe & cabriolet, 33-34 closed car, RH, (flat base) (chrome).....	32-34	28.00 ea
40-702351	1932 3-window coupe & cabriolet, 33-34 closed car, LH, (flat base) (chrome).....	32-34	28.00 ea
40-702350/1	Same as above except stainless steel (RH & LH pairs only).....	32-34	120.00 pr
40-702350/1-L	1932 3-window coupe & cabriolet, 1933-1934 closed car, locking pair of RH & LH, chrome.....	32-34	65.00 pr

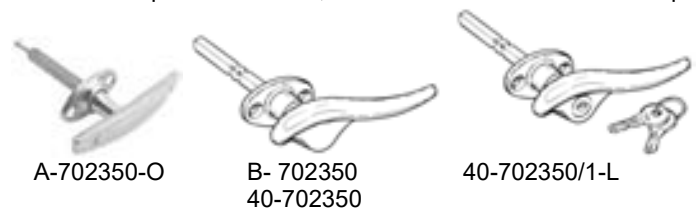

46-702350-P	Pickup, chrome	32-34	28.00 ea
48-702350	Passenger, chrome	1935	28.00 ea



50-702350	Pickup, chrome.....	35-36	28.00 ea
68-702350-A	Standard, chrome, straight handle.....	1936	28.00 ea



68-702350-B	Deluxe, chrome, curved handle, also 1937 pickup,	36-37	28.00 ea
78-702350	Passenger, chrome	1937	28.00 ea



81A-702350-A	Standard & 1938-1947 pickup, chrome	1938	28.00 ea
81A-702350-B	Deluxe, chrome	1938	28.00 ea



OUTSIDE DOOR HANDLES-continued

91A-702350	Passenger, chrome.....	1939	28.00 ea
01A-702350	Closed car, chrome.....	1940	28.00 ea
01A-702350-A	Convertible.....	1940	38.50 ea



11A-702350	Passenger, chrome.....	1941	ASK
51A-702350	Passenger, also early 1947, chrome.....	1946	28.00 ea
6A-702350	Passenger, also late 1947, chrome.....	1948	28.00 ea



TAILGATE HANDLE

48-702352-B	Wagon, chrome, with 2 keys	38-39	36.00 ea
A-702356-E	Handle pad for above, rubber ..	32-37	1.50 ea

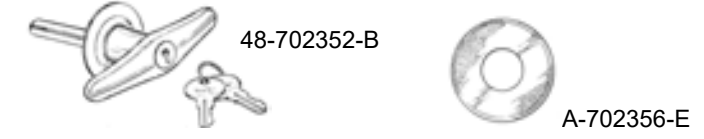

OUTSIDE DOOR HANDLE PADS-PAPER

Thick waterproof paper pads were used originally

B-7022428-P	Closed car	32-34	2.00 pr
B-7622428-P	Open car.....	32-34	2.00 pr
48-7022428-P	Open & closed car	35-37	2.00 pr
81A-7022428-P	Open & closed cars	38-39	2.00 pr

OUTSIDE DOOR HANDLE PADS-RUBBER

Rubber pads with beads are improved replacement for above paper pads

B-702356-AS	Roadster & phaeton	28-34	2.00 pr
B-702356-BS	1932-1934 passenger & 1930-1936 pickup, molded rubber.....	30-36	2.00 pr
48-702356	1935-1937 Passenger & 1937-1947 pickup, molded rubber	35-47	2.00 pr
81A-7022428	Passenger, molded rubber.....	38-39	4.00 pr
99A-7022428	Closed cars , also fits 1939 Mercury, molded rubber	1940	6.00 pr
01A-7622428	Convertible, molded rubber.....	1940	4.00 pr
11A-7922428-R	Station wagon, set of 4	41-48	20.00 set



OUTSIDE DOOR HANDLE SCREWS-Stainless Steel

A-80089	Use with metal framed doors, #10-32 x 1" long, 4 pieces.....	28-38	1.50 set
A-80089-W	Use with wood framed doors, 1 1/4" long, 4 pieces.....	28-37	1.50 set



COWL MOUNT RADIO ANTENNA

- B-18813-RB Stainless steel mast with **red ball** on top & bullet end on bottom of mast. Chrome trim caps35.00 ea
- HR-18813-SS2 Antenna as above except **stainless ball** on top.....25.00 ea

Works with modern & vintage, AM & FM radios & stereos

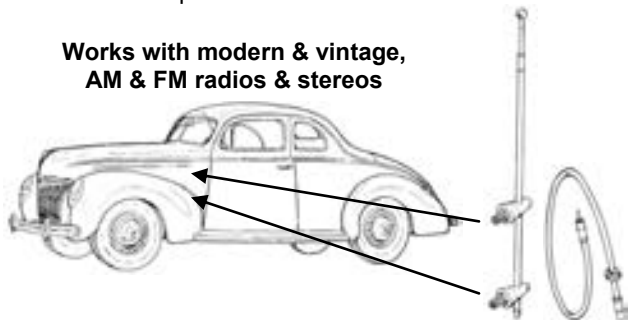

ANTENNAS – ORIGINAL STYLE

- 78-18813-AA Closed car, standard1937 150.00 kit
- 78-18813-AB Closed car, deluxe.....1937 150.00 kit
- 78-18813-B Open car & wagon.....,1937 150.00 kit
- 81A-18813-A Closed car1938 175.00 kit
- 81A-18813-B Open car & wagon.....1938 150.00 kit
- 91A-18813-A Closed car1939 ASK
- 91A-18813-B Open car & wagon.....1939 150.00 kit
- 99A-18813 Mercury, closed car1939 160.00 kit
- 99A-18813-A Mercury, open car & wagon.....1939 160.00 kit
- 01A-18813-A Closed car, Standard.....1940 100.00 kit
- 01A-18813-B Closed car, Deluxe1940 100.00 kit
- 01A-18813-C Open car & wagon.....1940 150.00 kit



01A-18813-C

- 09A-18813 Mercury, closed car1940 150.00 kit
- 09A-18813-A Mercury, open car & wagon.....1940 160.00 kit
- 11A-18813 Closed car1941 100.00 kit
- 11A-18813-A Open car & wagon.....1941 150.00 kit
- 21A-18813 Closed car *42-46 100.00 kit
- 21A-18813-A Open car & wagon, also fits 1946-48 *1942 150.00 kit

* Lead wire to radio not available



21A-18813

- 6A-18813 Cars, cowl mount antenna, also fits 1946.....47-48 90.00 kit



6A-18813

RADIO KNOB & FACE KITS

Components also offered individually on this page

- 01A-18803-PKIT Philco radio dial kit, 5 pieces. Includes dials, knobs & changer buttons1940 55.00 kit
- 01A-18803-ZKIT Zenith radio dial kit, 5 pieces. Includes dials, knobs & changer buttons1940 55.00 kit



- 11A-18810-P Philco & Sparton face, knob & selector dial kit, tan....1941 75.00 kit
- 11A-18810-Z Zenith face, knob & selector dial kit, tan1941 75.00 kit



11A-18810-P

SEE BELOW FOR COMPONENTS SOLD INDIVIDUALLY

RADIO FACE PLATES & DIAL BEZELS

- 81A-18802 Radio dial bezel.....1938 33.00 ea
- 01A-18802-P Radio cover1940 35.00 ea
- 01A-18802-Z Radio cover1940 35.00 ea
- 11A-18802-P Radio face plate, Philco, tan Model #F-1 840 & #F 1 841 Sparton model #6F1D1941 60.00 ea
- 11A-18802-Z Radio face plate, tan, Zenith Model #M F-590 \$ 6M F-591 1941 60.00 ea



81A-18802

01A-18802-P

01A-18802-Z



11A-18802-P



11A-18802-Z

RADIO CHANGE BUTTONS

- 01A-18804-P Philco (station selector), white . 1940 10.00 ea
- 01A-18804-Z Zenith (station selector), white . 1940 10.00 ea



01A-18804-P

01A-18804-Z

RADIO DIALS

- 01A-18805-P Philco1940 30.00 pr
- 01A-18805-Z Zenith1940 30.00 pr



01A-18805-P

01A-18805-Z

RADIO SELECTOR KNOBS

- 11A-18804-P Philco, light tan..... 1941 6.00 ea
- 11A-18804-S Sparton, light tan..... 1941 ASK
- 11A-18804-Z Zenith, light tan 1941 ASK



RADIO KNOBS

40-18803	Ash tray radio, brown marble.....	33-34	15.00	pr
40-18803-G	With shaft, glove box, Grisby, Brown marble	33-34	20.00	pr
40-18803-Z	With shaft, glove box, Zenith	33-34	20.00	pr



40-18803



40-18803-G



40-18803-Z

48-18803-A	Standard, maroon.....	1935	15.00	pr
48-18803-B	Deluxe, ivory.....	1935	15.00	pr
68-18803-A	Early 1936 standard, dark brown.....	1936	15.00	pr
68-18803-B	Early 1936 deluxe, tenite gray ..	1936	15.00	pr
68-18803-C	Late 1936 deluxe, red brown	1936	15.00	pr
78-18803-A	Standard, light brown	1937	15.00	pr
78-18803-B	Deluxe, yellow brown	1937	15.00	pr



48-18803



68-18803



78-18803

81A-18803	Standard & deluxe, ivory	1938	10.00	pr
01A-18803-P	Philco, dials & button, white.....	1940	30.00	pr
01A-18803-Z	Zenith, dials & button, white	1940	30.00	pr
11A-18803	All styles, tan	1941	15.00	pr



81A-18803



01A-18803-P



01A-18803-Z



11A-18803

ANTENNA HOLE PLUGS

Plugs hole in dash when antenna is not used.

01A-7004395-A	Sand, standard.....	1940	7.00	ea
01A-7004395-B	Maroon, deluxe.....	1940	7.00	ea
11A-7004395	Light tan.....	1941	7.00	ea
21A-7004395-A	Maroon, standard	1942	7.00	ea
21A-7004395-B	Butterscotch, deluxe and super deluxe	1942	7.00	ea
51A-7004395-A	Chocolate brown, deluxe	1946	7.00	ea
51A-7004395-B	Metallic blue gray, super deluxe.....	1946	7.00	ea
51A-7004395-C	Gray-tan	46-48	7.00	ea



01A-7004395
11A-7004395



21A-7004395
51A-7004395

ANTENNA TURN KNOBS

78-18815-A	Turn knob, standard	1937	15.00	ea
78-18815-B	Turn knob, deluxe.....	1937	15.00	ea
81A-18815	Turn knob	1938	15.00	ea
91A-18815	Turn knob	1939	15.00	ea
99A-18815	Turn knob, Mercury	1939	15.00	ea
01A-18815	Turn knob, open car & wagon ...	1940	15.00	ea
11A-18815	Turn knob, open car & wagon ...	1941	15.00	ea



78-18815



91A-18815



11A-18815

ANTENNA SLIDE NUTS

01A-18816-A	Standard, sand.....	1940	7.00	ea
01A-18816-B	Deluxe, maroon.....	1940	7.00	ea
09A-18816	Mercury, dark blue	1940	7.00	ea
11A-18816	Light tan	1941	8.00	ea
21A-18816	Closed car.....	42-48	8.00	ea



01A-18816-A



11A-18816

ANTENNA AERIAL STOPS

78-18820-A	Aerial stop **, closed car	37-39	13.00	ea
78-18820-B	Aerial stop **, open car	37-39	13.00	ea
01A-18820	Aerial stop **, open car & wagon. .	1940	13.00	ea

** Snaps on center windshield bar

Note: The above knobs & stops are included in antenna kits



78-18820-A



78-18820-B



01A-18820

MISCELLANEOUS RADIO PARTS

01A-18807	Radio hooks	40-41	10.00	pr
21A-18807	Radio hooks	42-48	10.00	pr
01A-18808	Radio nut.....	40-41	10.00	ea



01A-18807



21A-18807



01A-18808

RADIO SPEAKER BOOTS

Molded boots insulate the speaker to eliminate rattles

91A-18820	Cars, sponge rubber	1939	40.00	ea
01A-18820-BOOT	Cars, sponge rubber.....	1940	65.00	ea



91A-18820



01A-18820-BOOT

RADIO DIAL FACE PLATES

40-18802	Ash tray radio.....	33-34	14.00	ea
40-18802-G	Glove box radio, Grisby	33-34	14.00	ea
40-18802-Z	Glove box radio, Zenith	33-34	14.00	ea
48-18802	Gray background 35- Early 36 .	35-36	10.00	ea
68-18802	Brown background	1936	10.00	ea



40-18802



40-18802-G



40-18802-Z



48-18802



68-18802

DASH KNOB SETS 1932-1935 CARS

Knobs can be purchased in kits or individually

B-9270	Kit includes (4) knobs below, mahogany with white letters, 4 cylinder.....	1932	35.00 set
B-9703	Choke.....	1932	10.00 ea
18-9778	Throttle.....	1932	13.00 ea
18-13741	Dash light.....	1932	10.00 ea
B-11500	Starter knob	1932	10.00 ea
18-9270	Kit includes (3) knobs below, mahogany with white letters, V8 ..	1932	30.00 set
18-9703	Choke.....	1932	13.00 ea
18-9778	Throttle.....	1932	13.00 ea
18-13741	Dash light.....	1932	10.00 ea
40-9270-A	Kit includes knobs below, Mahogany with white letters.....	1933	36.00 set
18-9703	Choke.....	1933	13.00 ea
18-9778	Throttle	1933	13.00 ea
40-701656-A	Glove box	1933	11.00 ea
40-701606-A	Ash tray	1933	10.00 ea
40-9270-B	Kit includes knobs below, brown marble with white letters....	1934	36.00 set
40-9703	Choke	1934	12.00 ea
40-9778	Throttle	1934	13.00 ea
40-701656-B	Glove box	1934	11.00 ea
40-701606-B	Ash tray	1934	10.00 ea



48-9270-A	Kit includes knobs below, maroon with white letters, Standard.....	1935	60.00 kit
48-9703-A	Choke	1935	13.00 ea
48-9778-A	Throttle.....	1935	13.00 ea
48-701638-A	Cigar	1935	10.00 ea
48-13741-A	Dash light.....	1935	10.00 ea
48-701656-A	Glove box.....	1935	12.00 ea
48-18803-A	Radio	1935	20.00 pr
48-9270-B	Kit includes knobs below, ivory with mahogany letters, Deluxe	1935	60.00 kit
48-9703-B	Choke	1935	13.00 ea
48-9778-B	Throttle.....	1935	13.00 ea
48-701638-B	Cigar	1935	10.00 ea
48-13741-B	Dash light.....	1935	10.00 ea
48-701656-B	Glove box.....	1935	12.00 ea
48-18803-B	Radio	1935	20.00 pr



DASH KNOB SETS 1936-1937 CARS

Knobs can be purchased in kits or individually

68-9270-A	Kit includes knobs below, dark brown & white letters Standard, early.....	1936	60.00 kit
68-9703-A	Choke	1936	13.00 ea
68-9778-A	Throttle	1936	13.00 ea
68-701638-A	Cigar	1936	10.00 ea
68-13741-A	Dash light	1936	10.00 ea
68-701656-A	Glove box	1936	10.00 ea
68-18803-A	Radio	1936	20.00 pr
68-7004830-A	Ashtray knob (not included in kit).	1936	9.00 ea
68-9270-B	Kit includes knobs below, tenite light Grey/ white letters, Deluxe early...	1936	60.00 kit
68-9703-B	Choke	1936	13.00 ea
68-9778-B	Throttle	1936	13.00 ea
68-701638-B	Cigar	1936	10.00 ea
68-13741-B	Dash light	1936	10.00 ea
68-701656-B	Glove box	1936	10.00 ea
68-18803-B	Radio	1936	20.00 pr
68-7004830-B	Ashtray knob (not included in kit).	1936	9.00 ea
68-9270-C	Kit includes knobs below, reddish brown, Deluxe & Standard	1936	60.00 kit
68-9703-C	Choke	1936	13.00 ea
68-9778-C	Throttle	1936	13.00 ea
68-701638-C	Cigar	1936	10.00 ea
68-13741-C	Dash light	1936	10.00 ea
68-701656-C	Glove box	1936	10.00 ea
68-18803-C	Radio	1936	20.00 pr
68-7004830-C	Ashtray knob (not included in kit).	1936	9.00 ea



78-9270-A	Kit includes knobs below, light brown with black letters, Standard	1937	60.00 kit
78-9703-A	Choke	1937	13.00 ea
78-9778-A	Throttle	1937	13.00 ea
78-15053-A	Cigar	1937	10.00 ea
78-13741-A	Dash light	1937	10.00 ea
78-701606-A	Ash tray	1937	10.00 ea
78-18803-A	Radio	1937	20.00 pr
78-9270-B	Kit includes knobs, yellow brown with black letters, Deluxe	1937	60.00 kit
78-9703-B	Choke	1937	13.00 ea
78-9778-B	Throttle	1937	13.00 ea
78-15053-B	Cigar	1937	10.00 ea
78-13741-B	Dash light	1937	10.00 ea
78-701606-B	Ash tray	1937	10.00 ea
78-18803-B	Radio	1937	20.00 pr



DASH KNOB SETS 1938-1942 CARS

Knobs can be purchased in kits or individually

81A-9270	Kit includes knobs below, ivory pink	1938	47.00 kit
81A-9703	Choke	1938	14.00 ea
81A-9778	Throttle.....	1938	14.00 ea
81A-15053	Cigar	1938	12.00 ea
81A-701606	Ash tray.....	1938	12.00 ea
81A-7330710	Ash tray knob for rear seat, (Not included in kit)	1938	25.00 ea
91A-9270	Kit includes knobs below, yellow brown with black letters	1939	37.00 kit
91A-9703	Choke	1939	13.00 ea
91A-9703	Throttle.....	1939	13.00 ea
91A-15053	Cigar	1939	9.00 ea
91A-701606	Ash tray.....	1939	9.00 ea
91A-7330710	Ash tray knob for rear seat, (Not included in kit)	1939	25.00 ea
99A-9270	Kit includes knobs below, light peach black letters, MERCURY ..	1939	65.00 kit
99A-9703	Choke	1939	14.00 ea
99A-9778	Throttle.....	1939	14.00 ea
99A-13740	Dash light.....	1939	12.00 ea
99A-15053	Cigar	1939	12.00 ea
99A-701606	Ash tray.....	1939	22.00 pr
99A-7330710	Ash tray knobs for rear seat, (Not included in kit)	1939	20.00 set
99A-3690	On/Off switch knob, Mercury, not included in kit above	1939	12.00 ea



01A-9270-A	Kit includes knobs below, sand with maroon letters, Standard	1940	50.00 kit
01A-9703-A	Choke	1940	11.00 ea
01A-9778-A	Throttle.....	1940	13.00 ea
01A-11661-A	Headlight.....	1940	13.00 ea
01A-15053-A	Cigar	1940	10.00 ea
01A-701606-A	Ash tray.....	1940	10.00 pr
01A-9270-B	Kit includes knobs below, maroon with white letters, Deluxe	1940	50.00 kit
01A-9703-B	Choke	1940	13.00 ea
01A-9778-B	Throttle.....	1940	13.00 ea
01A-11661-B	Headlight.....	1940	13.00 ea
01A-15053-B	Cigar	1940	10.00 ea
01A-701606-B	Ash tray.....	1940	10.00 pr



DASH KNOB SETS 1938-1942 CARS-continued

Knobs can be purchased in kits or individually

09A-9270	Kit includes knobs below, dark blue w/ white letters, MERCURY	1940	90.00 kit
09A-9703	Choke	1940	12.00 ea
09A-9778	Throttle	1940	12.00 ea
09A-11661	Headlight	1940	13.00 ea
09A-15053	Cigar	1940	12.00 ea
09A-7002145	Cowl vent.....	1940	15.00 ea
09A-11500	Starter button.....	1940	15.00 ea
09A-17513	Wiper	1940	12.00 ea
09A-7213	Gearshift.....	1940	15.00 ea
11A-9270	Kit includes knobs below, light tan with red letters , FORD	1941	70.00 kit
11A-9703	Choke	1941	10.00 ea
11A-9778	Throttle	1941	10.00 ea
11A-11661	Headlight	1941	13.00 ea
11A-701638	Cigar	1941	15.00 ea
11A-16917	Hood pull	1941	15.00 ea
11A-13741	Dash dimmer	1941	12.00 ea
11A-17513	Wiper	1941	10.00 ea
11A-7213	Gearshift.....	1941	15.00 ea



21A-9270-A	Kit includes knobs below, maroon with red letters	1942	85.00 kit
21A-9703-A	Choke	1942	10.00 ea
21A-9778-A	Throttle	1942	10.00 ea
21A-11661-A	Headlight	1942	12.00 ea
21A-701638-A	Cigar	1942	15.00 ea
21A-701606-A	Ash tray	1942	15.00 pr
21A-16918-A	Hood pull	1942	12.00 ea
21A-17513-A	Wiper	1942	10.00 ea
21A-7213-A	Gearshift.....	1942	15.00 ea

21A-9270-B	Kit includes knobs below, butterscotch with red letters	1942	85.00 kit
21A-9703-B	Choke	1942	10.00 ea
21A-9778-B	Throttle	1942	10.00 ea
21A-11661-B	Headlight	1942	12.00 ea
21A-701638-B	Cigar	1942	15.00 ea
21A-701606-B	Ash tray	1942	15.00 pr
21A-16918-B	Hood pull	1942	12.00 ea
21A-17513-B	Wiper	1942	10.00 ea
21A-7213-B	Gearshift.....	1942	15.00 ea



DASH KNOB SETS 1946-1948 CARS

Knobs can be purchased in kits or individually

51A-9270-A	Kit includes knobs below, chocolate brown with red letters, Deluxe	1946	85.00	kit
51A-9703-A	Choke	1946	10.00	ea
51A-9778-A	Throttle	1946	10.00	ea
51A-11661-A	Headlight	1946	13.00	ea
51A-701638-A	Cigar	1946	15.00	ea
51A-701606-A	Ash tray	1946	15.00	pr
51A-16918-A	Hood pull	1946	12.00	ea
51A-17513-A	Wiper	1946	10.00	ea
51A-7213-A	Gearshift	1946	15.00	ea

51A-9270-B	Kit includes knobs below, metallic blue grey with red letters, Super Deluxe	1946	75.00	kit
51A-9703-B	Choke	1946	10.00	ea
51A-9778-B	Throttle	1946	10.00	ea
51A-11661-B	Headlight	1946	13.00	ea
51A-701638-B	Cigar	1946	15.00	ea
51A-701606-B	Ash tray	1946	15.00	pr
51A-16918-B	Hood pull	1946	10.00	ea
51A-17513-B	Wiper	1946	10.00	ea
51A-7213-B	Gearshift	1946	15.00	ea



51A-9270-A



51A-9270-B

51A-9270-C	Kit includes knobs below, grayish tan with red letters, Super Deluxe	1946	75.00	kit
51A-9703-C	Choke	1946	10.00	ea
51A-9778-C	Throttle	1946	10.00	ea
51A-11661-C	Headlight	1946	13.00	ea
51A-701638-C	Cigar	1946	15.00	ea
51A-701606-C	Ash tray	1946	15.00	pr
51A-16918-C	Hood pull	1946	10.00	ea
51A-17513-C	Wiper	1946	10.00	ea
51A-7213-C	Gearshift	1946	15.00	ea



51A-9270-C



6A-9270

6A-9270	Kit includes knobs below, grayish tan with black letters	47-48	80.00	kit
6A-9703	Choke	47-48	10.00	ea
6A-9778	Throttle	47-48	10.00	ea
6A-11661	Headlight	47-48	13.00	ea
6A-701638	Cigar	47-48	15.00	ea
51A-701606-C	Ash tray	47-48	15.00	pr
6A-16918	Hood pull	47-48	10.00	ea
51A-17513-C	Wiper	47-48	10.00	ea
51A-7213-C	Gearshift	47-48	15.00	ea

DASH KNOBS 1932-1947 TRUCKS

Knobs can be purchased in kits or individually

18-9270-T	Kit includes below, mahogany	32-34	35.00	set
18-9703	Choke	32-34	13.00	ea
18-9778	Throttle	32-34	13.00	ea
40-701656-A	Glove Box	32-34	11.00	ea
50-9270	Kit includes below, dark brown	35-39	35.00	set
68-9703-A	Choke	35-39	13.00	ea
68-9778-A	Throttle	35-39	13.00	ea
68-701656-A	Glove Box	35-39	11.00	ea



18-9270-T



50-9270

01C-9270	Kit including knobs below, sand	1940	60.00	set
01A-9703-A	Choke	1940	13.00	ea
01A-9778-A	Throttle	1940	13.00	ea
01A-11661-A	Headlight	1940	13.00	ea
01A-11500-A	Starter button	1940	13.00	ea
01A-7002145-A	Cowl vent knob	1940	10.00	ea

11C-9270	Kit including knobs below, Black with red letters	41-47	67.00	set
11C-9703	Choke	41-47	15.00	ea
11C-9778	Throttle	41-47	15.00	ea
11C-11661	Headlight	41-47	13.00	ea
21C-11500	Starter button	41-47	13.00	ea
11C-8102145	Cowl vent knob	41-47	13.00	ea



01C-9270



11C-9270

CIGARETTE ELEMENTS & WELLS 1932-1934

B-15055	Well for knob, has element & wiring	32-34	40.00	ea
B-15055-R	Well for knob, as above except no element or wiring	32-34	25.00	ea



B-15055



B-15055-R

CIGAR LIGHTER KNOBS 1932-1934

Brown marble effect with green eye, like original. Looks correct but does not use an element.

B-15053-R	Cigar knob only	1932	35.00	ea
40-15053-R	Cigar knob only	33-34	35.00	ea



B-15053-R



40-15053-R

CIGARETTE ELEMENTS & WELLS 1935-1948

Replacement type for studded cigar knobs

11A-15055	6 volt	35-48	20.00 ea
B6C-15055	12 volt	35-48	15.00 ea



CIGAR LIGHTER KNOBS 1935-1940

All knobs below come with stud for replacement element & wells offered above.

48-15053-AR	Maroon, standard	1935	12.00 ea
48-15053-BR	Ivory, deluxe	1935	12.00 ea
68-15053-AR	Dark brown, early Standard	1936	12.00 ea
68-15053-BR	Tenite gray, early 1936 Deluxe	1936	12.00 ea
68-15053-CR	Red-brown, late 1936 Dix & Std.	1936	12.00 ea
78-15053-AR	Light brown, standard	1937	12.00 ea
78-15053-BR	Yellow brown, deluxe	1937	12.00 ea
01A-15053-AR	Sand, standard	1940	12.00 ea
01A-15053-BR	Maroon, deluxe	1940	12.00 ea



For original style cigar knobs 1932-40 and 1941-48 knobs, see listings within dash knob section on previous page.

COWL VENT / GEAR SHIFT PLASTIC KNOBS

78-7002145-A	Light brown, standard	1937	10.00 ea
78-7002145-B	Yellow brown, deluxe	1937	10.00 ea
81A-7002145	Ivory, standard & deluxe	1938	10.00 ea
91A-7002145	Light yellow, standard and deluxe	1939	10.00 ea
01A-7002145-A	Sand, standard	1940	10.00 ea
01A-7002145-B	Maroon, deluxe	1940	10.00 ea
11A-7213	Light tan, round shaft *	1941	15.00 ea
11A-7002145	Light tan, flat shaft	1941	10.00 ea
21A-7213-A	Maroon,*	1942	15.00 ea
21A-7213-B	Butterscotch, Deluxe & Super Deluxe	1942	15.00 ea
51A-7213-A	Chocolate brown, deluxe *	1946	15.00 ea
51A-7213-B	Metallic blue-gray, super Deluxe *	1946	15.00 ea
51A-7213-C	Gray-tan, 1946 club convertible, wagon & sportsman, and 1947-1948 all styles *	46-48	15.00 ea

* Also used as gear shift knob



78-7002145-A	78-7002145-B	01A-7002145-B	11A-7213
91A-7002145		21A-7213-A	21A-7213-B
01A-7002145-A		81A-7002145	51A-7213-A
		51A-7213-B	51A-7213-C

COWL VENT HANDLES

B-700611	Chrome, 1932 car and 1932-1934 pickup	32-34	24.00 ea
40-700612	Polished aluminum, car	33-36	24.00 ea
50-810612	Polished aluminum, pickup	35-36	24.00 ea



B-700611

40-700611



50-810612

COWL VENT HINGES

B-35260	Hinge, 1932 car and 1932-1934 pickup	32-34	25.00 ea
40-35260	Hinge, car	33-34	25.00 ea



B-35260



40-35260

COWL VENT RATCHETS & SPRINGS

B-35276	Ratchet only, 1932 car & 1932-1934 pickup	32-34	8.00 ea
40-35276	Ratchet only, 1933-34 car & 1935-1936 pickup	33-36	8.00 ea
B-35269	Spring only, 1932 car and 1932-1934 pickup	32-34	3.50 ea
40-35269	Spring only, 1933-1934 car & 1935-1937 pickup	33-37	3.50 ea
48-700620-K	Ratchet with 2 springs, car	35-36	20.00 kit



B-35276



B-35269



40-35269



48-700620-K

COWL VENT GASKETS

B-700616	1932 car & 1932-34 pickup *	32-34	20.00 ea
40-700616-D	1933-34 & 1935-36 pickup	33-36	20.00 ea
48-700616-D	Cars	35-36	20.00 ea
78-7002330	1937-1938 cars & pickups	37-48	20.00 ea
91A-7002330	Cars & pickup *	39-42	20.00 ea
51A-7002330	1946-1948 cars and 1946-1947 pickup*	46-48	20.00 ea

*B-700616, 91A-7002330 & 51A-7002330 molded with raised ribs.



B-700616



40-700616 48-700616



78-7002330 91A-7002330 51A-7002330

COWL VENT SCREENS

B-700590	1932 cars & 1932-34 pickups not original but reproduction of accessory	32-34	55.00 ea
40-700590	1934 cars & 1935-36 pickups	34-36	40.00 ea
48-700590	Cars	35-36	40.00 ea
78-700590	Cars & pickups	37-38	40.00 ea
91A-7002280	1939-40 cars & 1939-47 pickup	39-47	40.00 ea
21A-7002280	Cars	41-48	40.00 ea



48-700590

DASH INSTRUMENT PANEL-1932 PASSENGER

18-11804 Stainless steel stamping engine turned design..... 1932 60.00 ea



DASHBOARD TO DASH RAIL SCREW SET-1932

Holds main dash panel body to body rail, under windshield

B-11810-OSS Open car, stainless steel 1932 2.50 set
 B-11810-SS Closed car, stainless steel..... 1932 2.50 set



GLOVE BOX DOOR PARTS 1933-1934

40-43000-RK Door repair kit, includes: bumper, clip & spring..... 33-34 9.50 kit
 40-701674 Door spring pin 33-34 7.75 ea
 40-701662 Door hinge only 33-34 18.00 ea



40-43000-RK

40-701674

40-701662

40-701650 Glove box door, steel 33-34 50.00 ea



Front side

40-701650



Back side

GLOVE BOX DOOR SPRING CLIPS 1935-1941

48-701674 Door spring clip, 1935-1937 passenger, 1935-1940 pickup, 2 required 35-41 5.50 ea
 81A-701674 Door spring clip, 1938-1939 passenger & 1944-1950 pickup, 2 required..... 38-50 5.50 ea



48-701674



81A-701674

DASH PANEL PARTS – 1940 CARS

01A-303 Dash panel all stock openings except for ash tray holes 1940 485.00 ea
 01A-302 Dash panel with glove box opening only 1940 485.00 ea



01A-303

01A-7006020-A Glove box door, Standard 1940 75.00 ea

01A-7006020-B Glove box door, deluxe with clock port & dash trim holes 1940 75.00 ea

01A-4004438-AP Instrument cluster panel, 1940 standard car & 40-47 pickup.. 40-47 75.00 ea



01A-7006020-A



01A-7006020-B

DASH PANEL PARTS – 1940 CARS-continued

01A-9271-C Instrument cluster panel, die cast, chrome plated, Deluxe 1940 48.00 ea
 01A-7004401-B instrument cluster panel, sand plastic, includes 01A-10861 gasket (below), Deluxe car..... 1940 55.00 ea
 01A-10861 Instrument cluster bezel to glass gasket only 1940 7.00 ea
 01A-7004690-K Dash trim set, deluxe, chrome, 6 piece set with clips 1940 70.00 set
 01A-7004352 Radio speaker grille, chrome ... 1940 70.00 ea
 01A-9272-SSC Radio opening block-off plate, stainless steel * 1940 15.00 ea



01A-9271-C



01A-7004401-B



01A-7004352



01A-9272-SSC



01A-7004690-K

01A-9271-C

01A-7004401-B

01A-9272-SSC

01A-7004690-K



1940 DELUXE DASH

01A-7004352

Clock Bezel **

Clock Knob **

* See radio parts section on previous pages for original radio plastic bezels

** See next pages for clock knobs & bezels

DASH LIGHT , GLOVE BOX WIRES & SOCKETS

40-13710 Dash light, 11-1/4" long, cars..... 33-34 8.00 ea
 48-13710 Dash light, 2 wires, car 35-39 15.00 ea
 99A-13710 Dash light, Mercury only 1939 18.50 ea
 59A-13712 Glove box wire, 6" long, Mercury only..... 46-48 21.25 ea

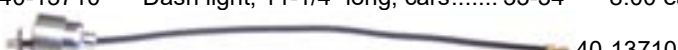

40-13710

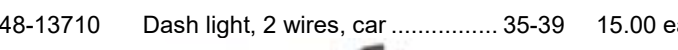

48-13710 Dash light, 2 wires, car 35-39 15.00 ea



48-13710

99A-13710 Dash light, Mercury only 1939 18.50 ea

59A-13712 Glove box wire, 6" long, Mercury only..... 46-48 21.25 ea

CENTER DASH TRIM 1941-1948

11A-7004402 Chrome 1941 27.00 ea
 21A-7004402 Chrome 42-48 45.00 ea



11A-7004402



21A-7004402

ORDER & INFORMATION LINE 1- 508-278-3980 TOLL FREE 1-800-508-3980 Email: joesantique@charter.net

DASH BEZELS & GRILLES 1941 CARS

11A-7004401- Light tan, super deluxe, includes:
SAC Instrument & clock bezels..... 1941 ASK



11A-7004401-SAC

11A-7004401- Light tan, super deluxe, includes:
SA Instrument panel & passenger
panel (no clock) 1941 ASK



11A-7004401-SA

DASH BEZELS & GRILLES 1942-1948 CARS

3 piece sets offered below include speedometer, speaker grille & clock bezels

21A-7004401-SA	Maroon plastic.....	1942	200.00	set
21A-7004401-SB	Butterscotch plastic.....	1942	200.00	set
51A-7004401-SA	Chocolate brown plastic	1946	200.00	set
51A-7004401-SB	Metallic blue grey plastic ...	1946	200.00	set
51A-7004401-SC	Gray tan plastic	1946	200.00	set
6A-7004401-SC	Gray tan plastic	47-48	190.00	set
21A-9271-C	Chrome plated, die cast	42-48	240.00	set
M-9271	Mercury, die cast, not plated, ready to paint.....	42-48	290.00	set



21A-7004401 51A-700440
6A-7004401 21A-9271-C

M-9271-C

HI-BEAM SOCKET & JEWELS

81A-13580	Socket & wire for jewel	38-47	30.00	ea
81A-13580A/LS	Socket wire only for jewel.....	38-47	3.00	ea
81A-13583	Hi-beam jewel.....	38-40	10.00	ea
01C-13583	Hi-beam jewel, pickups.....	40-47	10.00	ea



81A-13580

81A-13583

01C-13583

INSTRUMENT PANEL LIGHT SWITCH

40-13740	1933-1938 passenger, 1939 standard passenger, 1933-1951 pickup, 1940-1944 panel & 1938 passenger fresh air heater switch	33-47	9.75	ea
----------	--	-------	------	----



40-13740

Typical dash light dimmer switches
(See below)

INSTRUMENT PANEL LIGHT DIMMER SWITCHES

Adjusts amount of light to the instrument / dash panel

01A-13740-A	Standard, sand knob	1940	25.00	ea
01A-13740-B	Deluxe, maroon knob	1940	25.00	ea
21A-13740-A	Maroon knob	1942	25.00	ea
21A-13740-B	Butterscotch knob.....	1942	25.00	ea
51A-13740-A	Chocolate knob	1946	25.00	ea
51A-13740-B	Metallic blue-gray knob.....	1946	25.00	ea
51A-13740-C	Gray-tan	47-48	25.00	ea
29A-13740	Black, Mercury.....	42-48	25.00	ea

GLOVE BOX LINERS

Glove boxes are die stamped out of waterproof cardboard and lined with original style type material. Includes mounting hardware and lid cover when required.

B-43000	3-window.....	1932	ASK
40-43000	All styles.....	33-34	22.00 ea
48-43000-AS	Closed cars.....	35-36	22.00 ea
48-43000-BS	Open cars	35-36	ASK
78-43000	All styles.....	1937	22.00 ea
81A-43000-AS	Closed cars	38-39	22.00 ea
81A-43000-BS	Open car & station wagon.....	38-39	22.00 ea
01A-43000	All styles.....	1940	22.00 ea
11A-43000	All styles.....	1941	ASK
21A-43000	All styles.....	42-48	22.00 ea
09A-43000	Mercury, all styles	1940	22.00 ea
59A-43000	Mercury, all styles	41-48	ASK
67-43000	Pickup	35-37	22.00 ea
77-43000	Pickup.....	38-39	22.00 ea
01C-43000	Pickup.....	40-47	22.00 ea

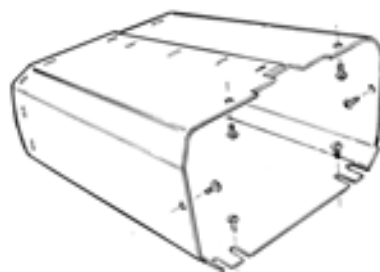

GLOVE BOX DOOR BUMPERS 1935-1948

48-701671-L	Thick for large gaps	35-48	2.00	pr
48-701671-S	thin for small gaps.....	35-48	2.00	pr

1 / 4" height



48-701671-L

3/16" height



48-701671-S

GLOVE BOX DOOR RELATED PARTS 1940-1948

01A-701662-S	Door hinge and striker plate kit, includes hardware.....	40-48	34.00	kit
01A-701671	Door stops, Ford & Mercury	40-48	9.00	pr
01A-7006081	Glove box latch with lock *	1940	45.00	ea
21A-7006081	Glove box latch with lock *	42-48	45.00	ea

* Includes 2 keys & installation screws



01A-701662-S



01A-701671



01A-7006081



21A-7006081

DOME LIGHTS & PARTS

A-13769	Dome light slide switch	28-48	8.50 ea
A-13770	Dome light switch chrome plate ...	28-48	ASK
8M-13713	Dome light switch for door jamb...	49-70	7.00 ea

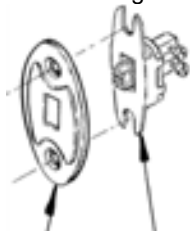

A-13770 A-13769



8M-13713

A-13771-WS	Dome light assembly <u>with</u> switch round style, chrome rim	28-48	50.00 ea
A-13771	Dome light assembly, <u>without</u> switch, round style, chrome rim....	28-48	45.00 ea



A-13771-WS



A-13771

A-13771-G	Dome light lens, white for A-13771 & A-13771-WS	28-48	8.00 ea
A-13771-C	Dome light lens snap ring for A-13771 & A-13771-WS, cadmium plated.....	28-48	5.00 ea



A-13771-G

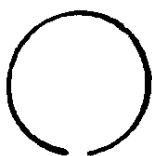

A-13771-C

01A-13779	Dome light assembly, oblong style, includes chrome rim, lens, gasket & wire	37-40	30.00 ea
81A-13783	Dome light lens, white for 01A-13779	37-40	5.00 ea
78-13783-G	Dome light lens cork gasket for 01A-13779	37-40	1.75 ea



01A-13779



81A-13783



78-13783-G

CLOCK KNOBS

81A-15032	Ivory, molded plastic	1938	6.00 ea
91A-15032	Light yellow, molded plastic	1939	6.00 ea
99A-15032	Pink, Mercury, molded plastic..	1939	6.00 ea
01A-15032	Sand, molded plastic.....	1940	6.00 ea



81A-15032



91A-15032

GLOVE BOX CLOCK FACES AND BEZEL

48-15034-G	Clock face, 35 to early 36.....	35-36	10.0 ea
68-15034-G	Clock face, late 36	1936	10.00 ea
01A-15034-W	West Clock face	1940	10.00 ea
01A-15034-N	New Haven face.....	1940	10.00 ea
01A-15030	Clock bezel, sand plastic.....	1940	20.00 ea
01A-9272-CPCD	Clock bezel as above except die cast chrome	1940	18.00 ea



48-15034-G



68-15034-G



01A-15034-N



01A-15034-W

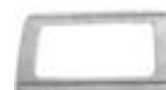

01A-15030



01A-9272-CPCD

MIRROR CLOCK FACES

B-15034	Round, black with silver text....	32-35	10.00 ea
68-15034-M	Round, brown.....	1936	9.50 ea



B-15034



68-15034-M

CLOCK WIRING

68-15026	Wire & socket, 32" (3 wires, 1 socket & 1 fuse)	1936	62.00 ea
78-15026	Wire & socket, 35" (3 wires & 1 socket)	1937	22.50 ea
01A-15026	Wire & socket, 9" (2 wires & 1 socket)	39-40	14.50 ea



01A-15026

99A-15026	Wire & socket, Mercury, 10" (3 wires & 1 socket)	1939	18.75 ea
09A-15026	Wire & socket, Mercury, 7" (3 wires & 1 socket)	1940	18.00 ea
21A-15026B	Wires & socket, 9" (2 wires & 2 sockets)	42-48	17.50 ea
59A-15026A	Wires & sockets, 9" (2 wires, 1 socket & 1 fuse)	46-48	51.00 ea



99A-15026A

59A-15026B	Wires & sockets, 11" (3 wires, 2 sockets & 1 fuse)	46-48	61.50 ea
------------	---	-------	----------



59A-15026B

HEATER RELATED PARTS

- 8H-18556-B Heater & defroster hose, 1 3/4" ..39-48 6.00 ft
- 01A-18491 Heater & defroster kit with
(2) nozzles & (2) 24" long
1 3/4" diameter hoses. 1940 69.00 kit



8H-18556-B



01A-18491

- 91A-15151/2 Heater hose bracket kit, secures
water heater hoses on top
on top of engine.....39-41 ASK
- 91A-18572 Water heater hose clamp39-48 2.00 ea



91A-15151/2



91A-18572

- FDA-18495-A Replacement hot water shut-off
valve, steel, 3/8" pipe thread ...39-56 18.00 ea
- 91A-15160 Heater hose nipple, use on
lower hose39-48 21.00ea

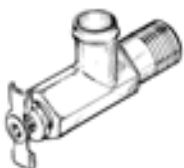

FDA-18495-A



91A-15160

HEATER BLOWER MOTORS-REPLACE MENT

- Motors are universal replacement type. Single speed.
- 18527-1741-6 6 volt.....41-48 45.00 ea
 - 18527-1741-12 12 volt.....41-48 45.00 ea



HEATER KNOBS

- 48-18500-A Maroon, Standard 1935 10.00 ea
- 48-18500-B Ivory, Deluxe 1935 10.00 ea
- 68-18500-A Dark brown, Standard early 1936 10.00 ea
- 68-18500-B Tenite grey, Deluxe, early 1936 10.00 ea
- 68-18500-C Red brown, deluxe, late 1936 10.00 ea
- 78-18500-A Light brown, Standard..... 1937 10.00 ea
- 78-18500-B Dark brown, Deluxe 1937 10.00 ea
- 81A-18500 Ivory pink..... 1938 10.00 ea
- 91A-18500 Yellow brown, Deluxe 1939 10.00 ea



48-18500



78-18500



91A-18500

HOT WATER HEATER DEFROSTER KNOBS

- 78-18501-A Light brown, Standard 1937 10.00 ea
- 78-18501-B Dark brown, Deluxe 1937 10.00 ea
- 81A-18501 Ivory pink..... 1938 10.00 ea
- 91A-18562 Light mint green 39-40 8.00 ea
- 91A-18562-W White..... 1939 8.00 ea
- 91A-18562-Y Yellow 1939 8.00 ea
- 11A-18562 Light tan 1941 8.00 ea
- 21A-18562-A Maroon..... 1942 8.00 ea
- 21A-18562-B Butterscotch..... 1942 8.00 ea
- 51A-18562-A Chocolate..... 1946 8.00 ea
- 51A-18562-B Blue gray..... 1946 8.00 ea
- 51A-18562-C Gray tan 1946 8.00 ea
- 6A-18562 Gray tan 47-48 8.00 ea



78-18501



91A-18562



21A-18562



6A-18562

HOT AIR DEFROSTER & HEATER KNOBS

- 91A-18502-PR Hot air heater & defroster, light
mint green with black letters..... 39-40 20.00 pr



91A-18502-PR

HOT WATER HEATER DOOR KNOBS

- 91A-18560-W Water heater door, white 1939 12.00 pr
- 91A-18560-Y Water heater door, light
yellow 1939 12.00 pr
- 01A-18560 Water heater door, light green,
2 pieces..... 1940 12.00 pr
- 11A-18560 Water heater door, black,
3 piece set..... 41-48 20.00 set
- 11A-18560-T Water heater door, tan,
3 piece set..... 41-48 20.00 set



91A-18560



01A-18560



11A-18560

SUN VISOR KITS- CARS & PICKUPS

B-47380/82-3W	3-Window coupe, chrome *... 1932	80.00 kit
40-47380/82-STD	Standard cars, chrome * 33-34	48.00 kit
68-47380-B	Cars, black * 35-48	50.00 kit
68-47380-C	Cars, chrome * 35-48	60.00 kit

* Visor frame only with mounting bracket, requires upholstery
 01C-8104101-C Pickups, chrome, less visor . 38-47 60.00 pr
 01C-8104104-BL Visor only, pickup, black 38-47 20.00 ea

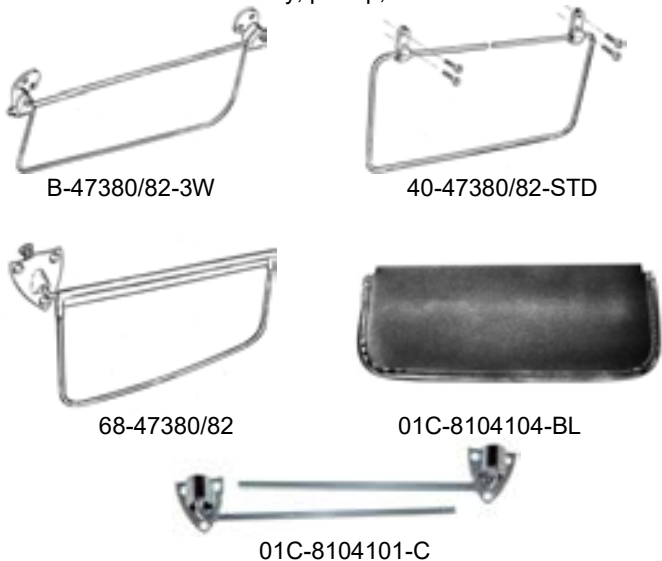

KICK PANEL RETAINER TRIM-CARS & PICKUPS

Require drilling. Some vehicles may require minor alteration.

78-7002354	Stainless steel. Sold each, 2 required per car 37-48	25.00 ea
------------	---	----------

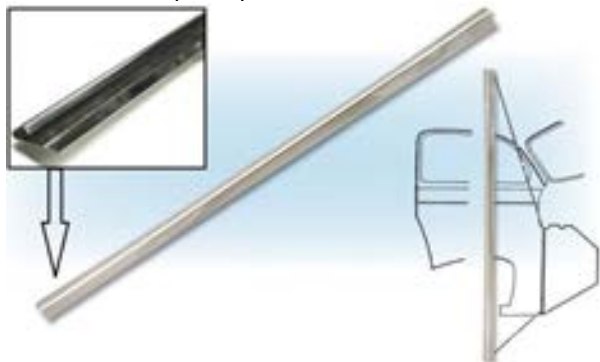

78-7002354 Kick panel trim

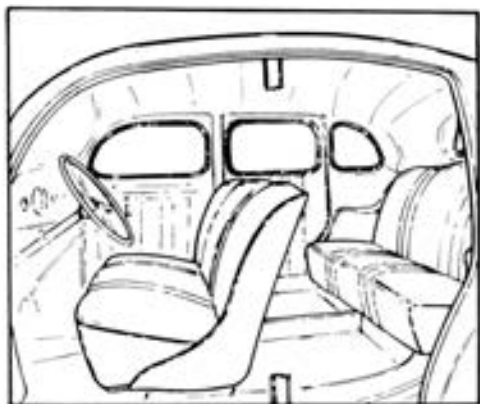

Complete original style car upholstery kits available
Sample cards & pricing available upon request!

ORIGINAL STYLE PICKUP HEADLINER & PANEL KITS

These kits are colored cardboard just like originals.
 Sets include headliner, one pair of corner panels, one pair of cowl panels, panel below rear window, door windlace, installation hardware & instructions. Door panels also included for 1935-39 but not for 1940-47 models

VPHP36B	Black.....	35-36	380.00 set
VPHP36N	Brown	35-36	380.00 set
VPHP37B	Black.....	.1937	380.00 set
VPHP37N	Brown1937	380.00 set
VPHP39B	Black.....	38-39	380.00 set
VPHP39N	Brown	38-39	380.00 set
VPHP39G	Green	38-39	380.00 set
VPHP47B-C*	Black.....	40-47	260.00 set
VPHP47N	Brown	40-47	325.00 set
VPHP47G	Green	40-47	325.00 set
VPHP47R	Red.....	40-47	325.00 set
VPHP47Y	Grey.....	40-47	325.00 set
VWL-T10	Vinyl windlace, black 10' roll.....		25.00 roll

Most headliner kits are not stocked (with the exception of VPHP47B-C) so please allow 5-7 weeks for delivery.

* VPHP47B-C is usually stocked and available for drop shipment within 3-4 days.

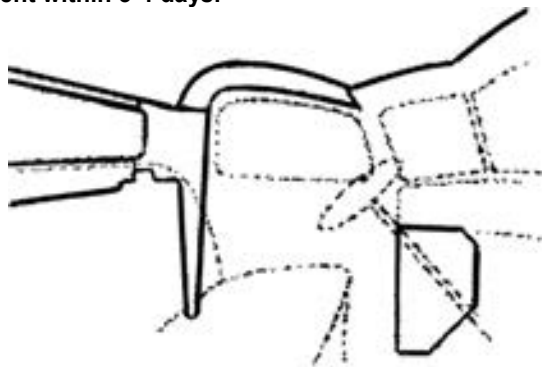

UPHOLSTERY SAMPLE CARDS AVAILABLE UPON REQUEST

PICKUP SEAT UPHOLSTERY KITS

Kits include: fitted seat covers sewn as original, padding for springs, installation hardware & instructions. These are quality kits manufactured using replacement type materials. No leather is used in any of these kits. Kits are made to order and not stocked. Please allow 2-5 weeks for delivery.

UCC83032-T10	Black.....	.1932	345.00 kit
UCC83032-T13	Grey1932	345.00 kit
UCC83032-T17	Brown1932	345.00 kit
UCC83033-T10	Black.....	.1933	345.00 kit
UCC83033-T17	Brown1933	345.00 kit
UCC83034-T10	Black.....	.1934	345.00 kit
UCC83034-T21	Red.....	.1934	345.00 kit
UCC83036-T10	Black.....	35-36	345.00 kit
UCC83036-T17	Brown	35-36	345.00 kit
UCC83039-T10	Black.....	37-39	345.00 kit
UCC83039-T17	Brown	37-39	345.00 kit
UCC83039-T20	Green	37-39	345.00 kit
UCC83047-T10	Black.....	40-47	345.00 kit
UCC83047-T13	Grey	40-47	345.00 kit
UCC83047-T17	Brown	40-47	345.00 kit
UCC83047-T20	Green	40-47	345.00 kit
UCC83047-T21	Red.....	40-47	345.00 kit

INTERIOR TRIM SCREW KITS

These kits include all screws necessary for the complete interior of the car, including window frame, dash rail, instrument panel, door step, and dove tail screws, also when required—the tube nuts. No rear window screws are included. All kits are made in the USA



1932			
B-80901A	Roadster, 72 pieces	1932	12.00 kit
B-80902A	Phaeton, 90 pieces.....	1932	12.00 kit
B-80903A	3-Window coupe, 128 pieces ...	1932	17.00 kit
B-80904A	5-Window coupe, 147 pieces ...	1932	25.00 kit
B-80905A	Tudor, 171 pieces.....	1932	25.00 kit
B-80906A	Fordor, 223 pieces	1932	25.00 kit
B-80906B	Victoria, 183 pieces	1932	24.00 kit
B-80906C	Convertible sedan (B-400), 179 pieces	1932	23.00 kit
B-80906D	Cabriolet, 138 pieces.....	1932	17.00 kit
B-80907A	Pickup, 131 pieces	32-34	12.00 kit

1933-1934			
40-80901B	Roadster, 46 pieces	33-34	10.00 kit
40-80902B	Phaeton, 76 pieces.....	33-34	12.00 kit
40-80903B	3-Window & 5-window coupe, 114 pieces	33-34	13.00 kit
40-80905B	Tudor, 116 pieces.....	33-34	13.00 kit
40-80906E	Fordor, 152 pieces	33-34	16.00 kit
40-80906F	Cabriolet, 92 pieces.....	33-34	12.00 kit
B-80907A	Pickup, 131 pieces	32-34	12.00 kit

1935-1936			
48-80901C	Roadster, 40 pieces	35-36	10.00 kit
48-80902C	Phaeton, 74 pieces.....	35-36	12.00 kit
48-80903C	Coupe, 87 pieces	35-36	11.00 kit
48-80904B	Tudor, 106 pieces.....	35-36	12.00 kit
48-80905C	Fordor, 119 pieces	35-36	15.00 kit
48-80906G	Cabriolet, 81 pieces.....	35-36	12.00 kit
48-80906H	Convertible sedan, 99 pieces ...	35-36	12.00 kit

1937			
78-80901D	Phaeton, 91 pieces.....	1937	12.00 kit
78-80902D	Coupe, 81 pieces	1937	11.00 kit
78-80903D	Tudor, 91 pieces.....	1937	11.00 kit
78-80904C	Fordor, 115 pieces	1937	13.00 kit
78-80905D	Cabriolet, 53 pieces.....	1937	11.00 kit
78-80906I	Convertible sedan, 80 pieces ...	1937	12.00 kit

1938-1939			
81A-80901E	Coupe, 67 pieces	38-39	12.00 kit
81A-80902E	Tudor, 75 pieces.....	38-39	11.00 kit
81A-80903E	Fordor, 101 pieces	38-39	11.00 kit
81A-80904D	Convertible, 64 pieces.....	38-39	13.00 kit
81A-80905E	Convertible sedan, 90 pieces ...	38-39	12.00 kit

INTERIOR TRIM SCREW KITS-continued

1940			
01A-80901F	Coupe, 69 pieces	1940	12.00 kit
01A-80902F	Tudor, 51 pieces	1940	10.00 kit
01A-80903F	Fordor, 101 pieces	1940	16.00 kit
01A-80904E	Convertible, 72 pieces	1940	13.00 kit

1940-1947			
01C-80901A	Pickup, 68 pieces	40-47	18.00 kit

1941			
11A-80901G	Coupe, 69 pieces	1941	10.00 kit
11A-80902G	Tudor, 55 pieces	1941	10.00 kit
11A-80903G	Fordor, 75 pieces	1941	11.00 kit
11A-80904F	Convertible, 51 pieces	1941	11.00 kit

1942-1948			
21A-80901H	Coupe & tudor, 55 pieces.....	42-48	10.00 kit
21A-80902H	Fordor, 75 pieces	42-48	11.00 kit
21A-80903H	Convertible, 72 pieces	42-48	11.00 kit

DOOR PANEL UPHOLSTERY CLIP SET

B-20015	All styles, 50 pieces	32-48	9.75 set
---------	-----------------------------	-------	----------



INTERIOR WINDOW GARNISH MOLDING CLIP

1938-39 Closed car

91A-7020930-B	Set of 10 clips.....	38-39	45.00 kit
91A-7020930-B-I	Clip sold individually	38-39	4.75 ea



SEAT UPHOLSTERY BUTTONS

51A-7063500-B	Super deluxe, blue-gray	1946	5.75 ea
51A-7063500-C	1946 Club convertible, wagon, and sportsman & 1947-1948 all styles, gray-tan	46-48	5.75 ea



51A-7063500-B

51A-7063500-C

SEAT PARTS

01A-7261710	Seat leg Bumpers, opera coupe, fits on bottom of seat legs.....	40-41	22.00 pr
-------------	--	-------	----------



B-47836	Seat adjustment handle, chrome ..	32-34	11.25 ea
---------	-----------------------------------	-------	----------



A-47907	Seat cushion dowel	21.00 ea
---------	--------------------------	----------



A-47907

WINDSHIELD RUBBER SEALS

PASSENGER CARS

B-7003110	Closed cars except 3-window Coupe by Carpenter.....	1932	20.00 ea
B-45504	Same as above by Drake.....	1932	50.00 ea
40-7003110	3/W coupe.....	1932	50.00 ea
A-37199-BS	Roadster & phaeton.....	30-32	8.50 ea
B-761290	Cabriolet & B-400, not bonded.....	32-34	40.00 ea
40-7003110	Closed car.....	33-34	50.00 ea
48-7003110	Closed car.....	35-36	20.00 ea
48-761290	Cabriolet, convertible sedan, and station wagon.....	35-36	100.00 ea
78-7003110	Closed car.....	37-39	20.00 ea
78-7603110	Convertible, cabriolet, conv sedan & station wagon.....	37-40	70.00 pr
99A-7003110	Mercury, all body styles	39-40	ASK
01A-7003110	Closed car, R.H. & L.H.....	1940	60.00 pr
01A-7003110-VB	For V-Butt or chopped windshields with <u>no</u> center bar, 10' length.....	1940	30.00 ea
11A-7603110	Ford/Mercury convertible, <u>with</u> groove for chrome strip.....	1941	90.00 ea
11A-7003110-A	Ford closed car, <u>without</u> groove for chrome strip.....	41-48	70.00 ea
11A-7003110-B	Ford/Mercury closed car and 42-48 convertible & station wagon, <u>with</u> groove for chrome strip.....	41-48	70.00 ea
11A-7003110-VB	For V-Butt or chopped windshields with <u>no</u> center bar, 12' length.....	41-48	30.00 ea

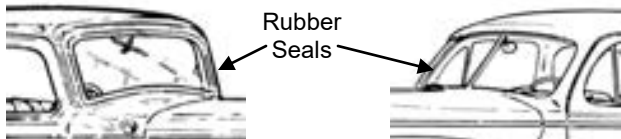

PICKUPS & COMMERCIALS

B-79500	Pickup, commercial and station wagon.....	32-34	10.00 ea
51-7003110	Pickup & commercial	35-36	25.00 ea
78-7003110	Pickup & commercial	37-39	20.00 ea
01A-7003110	R.H. & L.H.....	40-47	60.00 pr
01A-7003110-VB	For V-Butt or chopped windshields with <u>no</u> center bar, 10' length.....	40-47	30.00 ea



On 1932-1939 closed car, pickups and 1932-1936 open car styles, the windshield seal fits into the windshield frame and seals it to the body. Glass setting tape listed next is used for sealing the glass into the windshield frame.

WINDOW INSTALLATION TOOLS

TL-1002	Ball end hook tool for rubber glass seal	17.50 ea
TL-1001	Window seal tool stick.....	2.00 ea



WINDSHIELD HINGE HEADER SEAL

Pickups only

A-60550	Hinge header seal	28-34	5.00 ea
---------	-------------------------	-------	---------

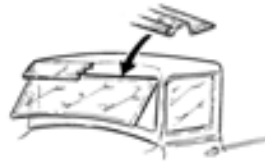

GLASS SETTING TAPE

All rubber or rubber/cork composition

B-37193-A	1/32" thick, 20' roll, rubber	32-48	10.00 ea
B-37193-B	3/64" thick, 20' roll, rubber	32-48	10.00 ea
B-37193-C	1/16" thick, 20' roll, rubber	32-48	12.00 ea
B-37193-D	5/64" thick, 20' roll, rubber	32-48	12.00 ea
A45963X	1/16" thick, 10' roll, rubber/cork ..	32-48	9.50 ea

Note: To determine the needed thickness: 1) measure the width of the glass, 2) measure the width of the channel that the glass fits into, 3) subtract the width of the glass from the width of the channel and 4) divide that figure by two.



REAR WINDOW SEALS

PASSENGER CARS

B-704220	All body styles, ends not bonded.....	32-36	8.00 ea
78-704220	1937 all styles, 1938 coupe & standard sedan, 1939-1940 coupe (Ford & Mercury)	37-40	30.00 pr
81A-704220	1938 deluxe sedan, 1939-1940 all sedans (Ford & Mercury).....	38-40	35.00 pr
11A-7042084	Coupe & sedan, without chrome strip (Ford)	41-48	28.00 ea
19A-7042084	Coupe & Sedan, with chrome strip (Mercury).....	41-48	28.00 ea



Rear window seals Quarter window seal

REAR WINDOW SEALS

PICKUPS AND COMMERCIALS

B-704220	Pickup, ends not bonded	32-39	8.00 ea
81T-7942084	Panel delivery	38-39	40.00 pr
01C-7042084	Pickup	40-47	30.00 ea
01A-7842084	Sedan delivery	40-41	40.00 ea
01C-7842084	Panel delivery	40-47	40.00 pr
21A-7842084	Sedan delivery	42-48	40.00 ea

REAR SLIDING WINDOW KITS-PICKUP

50-813396-K	Pickup	35-39	165.00 kit
01C-813396-K	Pickup	40-47	165.00 kit

QUARTER WINDOW SEAL - FIXED WINDOW

B-773540	Coupe, 10' length, ends not bonded	32-48	8.50 ea
B-7029904-B	5-Window coupe, bonded	1932	20.00 pr
40-7029904	5-Window coupe, bonded	33-34	20.00 pr
48-7029904	5-Widow coupe, bonded	35-36	20.00 pr
78-7029904	Coupe, bonded	37-40	20.00 pr

QUARTER WINDOW SEAL - PIVOT WINDOW

1938-1940 FORDOR
 81A-7329904-PR Fordor 38-40 100.00 pr

QUARTER WINDOW SEAL - PIVOT WINDOW

1941-1948 COUPE & FORDOR
 19A-7229904/5-B 1941-1946 (early) sedan coupe 41-46 115.00 pr
 51A-7229904/5-A 1946 (late), 1948 sedan coupe 46-48 100.00 pr
 11A-773540-S Fordor 41-48 65.00 pr

The 1941-1946 (early) metal frame surrounds the window glass completely. In late 1946, Ford modified the metal frame to only partially surround the window glass.



WINDOW FRAME SEALS - CONVERTIBLE

Fits into door or quarter window frame and holds glass.
 48-7621478 Convertible, door, 2 per car 35-48 9.50 kit
 21A-7629904 Convertible, quarter, 1 per car .. 42-48 12.00 kit



48-7621478 21A-7629904 21A-7630106-PR

QUARTER WINDOW FRONT EDGE SEAL- CONVERTIBLE

Includes special lower corners.
 21A-7630106-PR Convertible, RH & LH 42-48 45.00 pr

VENT WINDOW SEALS

01A-7021448/9 Closed car 1940 60.00 pr
 01A-6621448/9 Convertible, includes finish front finish strip 1940 80.00 pr
 21A-7021448/9 Closed car & station wagon .. 41-48 60.00 pr
 21A-7621448/9 Convertible, includes front finish strip 41-48 75.00 pr

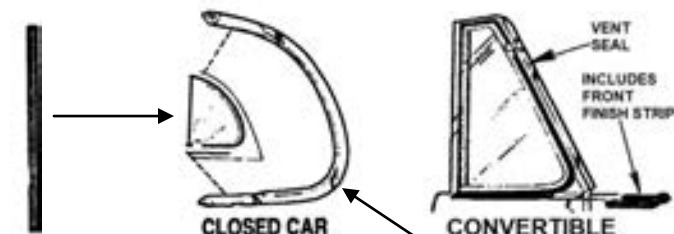

Glass edge Seal (See below) Vent window Seal (See above)

VENT WINDOW GLASS EDGE SEALS

All are extruded rubber with steel insert, except 1940 closed and 1941-42 closed which are the original wooly-strip type.

01A-7022296 Closed, wooly strip 1940 14.50 pr
 01A-7022296-A Convertible 1940 14.50 pr
 11A-7022296 Closed, wooly strip 41-42 14.50 pr
 11A-7022296-A Convertible 41-48 14.50 pr
 51A-7022296 Closed car 46-48 14.50 pr

DOOR GLASS TO METAL CHANNEL SEAL

Long lasting rubber extrusion with rain seal lip, 6' long, enough for 2 windows.
 B-7621478 Seal 28-38 7.50 ea



UPPER DOOR WINDOW SEAL

Sponge rubber strip seals glass at top of window.
 A-45985 Closed car, 30" length 32-33 5.00 ea

CONVERTIBLE WINDOW SEALS

This rubber seal fits in metal retainer on top bows and windshield post. Seals the door window frame when the window is rolled up. Available either non coated neoprene rubber surface or flocked (fuzzy).
 B-7651562 1" wide, non coated, 30" long 32-39 5.00 ea
 01A-7651562 3/4" wide, non coated, 30" long ... 40-48 5.00 ea
 18-45983 1" wide, flocked, 36" long 32-39 ASK
 01A-45983 3/4" wide, flocked, 36" long 40-48 14.00 ea



B-7651562 18-45983 01A-7651562 01A-45983

CONVERTIBLE WINDOW CHANNELS

Use with above seals. Stainless steel.
 18-45983-M 1" wide, 36" long 32-39 30.00 ea
 01A-45983-M 3/4" wide, 36" long 40-48 30.00 ea



CONVERTIBLE WINDSHIELD SEAL POST TO DOOR RUBBER SEALS

Molded legs and flocked like original.
 68-740928/9 Pair for RH & LH 35-39 20.00 ea
 01A-740928/9 Pair for RH & LH 1940 20.00 ea

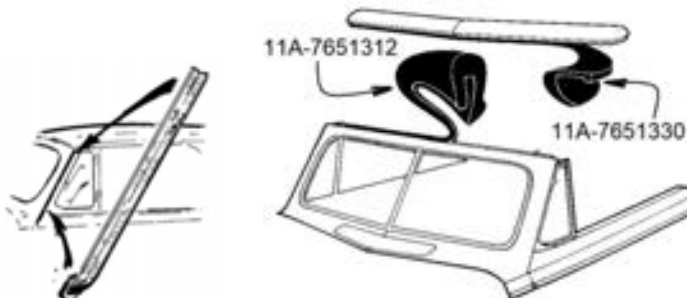

48-740928/9 Convertible Header Seals
 01A-740928/9

CONVERTIBLE HEADER SEALS

Seals between wood header and windshield header.
 48-7651312 1935-36 Cabriolet, Conv Sedan & 1937-1940 Convertible 35-40 8.00 ea
 11A-7651330 Convertible, (upper) 41-48 8.00 ea
 11A-7651312 Convertible, (lower) 41-48 8.00 ea

FRONT DOOR WINDOW CHANNEL KITS

1932-1934 Passenger & Pickup

One kit services both doors. Made in U.S.A.

1932

Includes molded channels with clips attached, upper window sponge seals, adhesive, lower cushion bumpers, door and garnish molding bumpers.

B-45983-3W	3-Window coupe	1932	90.00	kit
B-45983-5W/4D/2D	5-Window coupe	1932	90.00	kit
B-45983-5W/4D/2D	Tudor sedan	1932	90.00	kit
B-45983-5W/4D/2D	Fordor sedan	1932	90.00	kit
B-45983-V	Victoria & B-400	1932	90.00	kit
B-45983-PU	Pickup	32-34	110.00	kit

1933

Includes molded channels with clips attached, upper window sponge seals, adhesive, lower cushion bumpers, door and garnish molding bumpers.

18-45983-5W4D2D	5-Window coupe, tudor sedan, Victoria, fordor sedan	1933	90.00	kit
18-45983-3W	3-Window coupe	1933	90.00	kit
B-45983-PU	Pickup	32-34	110.00	kit

1934

There are two different types of doors, each requiring a different kit. If your inside door handle is located in the front of the door panel, order the kit with F at the end of the part number. If your inside door handle is located toward the center of the door panel, use the kit with C at the end of the part number. These kits include all the special metal and U-shape channels that are felted like the originals with the clips attached, door and garnish molding felt or bumpers, attaching screws and lower cushion bumpers.

40-45983-3W	3-Window coupe	1934	110.00	kit
40-45983-2DF	Tudor sedan, front mounted door handles	1934	125.00	kit
40-45983-2DC	Tudor sedan, center mounted door handles	1934	125.00	kit
40-45983-5WF	5-Window coupe, front mounted door handles	1934	125.00	kit
40-45983-5WC	5-Window coupe, center mounted door handles	1934	110.00	kit
40-45983-4DF	Fordor sedan, front mounted door handles	1934	110.00	kit
40-45983-4DC	Fordor sedan, center mounted door handles	1934	110.00	kit
B-45983-PU	Pickup	32-34	110.00	kit



48-45983-5WC

FRONT DOOR WINDOW CHANNEL KITS-continued

1935 & 1936 Passenger & 1935-1937 Pickup

One kit services both doors. Made in U.S.A.

There are two different types of doors, each requiring a different kit. If you have a U-shape channel with a rear metal bat wing channel and slots for rubber bumpers on the door and garnish moldings, order the kit with A at the end of the part number. If you have felt material (cat whiskers) all the way around the window on the garnish molding and door, order the kit with a B at the end of the part number. If you do not have any existing original channels, the best kit to use is the B kit. These kits include pre-bent door and garnish molding felt or rubber bumpers, all the special metal channels that are felted like originals with the clips attached and attaching screws.

48-45983-3WA	1935-1936 3-window coupe with rubber bumpers on garnish moldings & doors	35-36	110.00	kit
48-45983-3WB	1935-1936 3-window coupe with felt strips on garnish moldings & doors.....	35-36	125.00	kit
48-45983-2DA	1935-1936 tudor sedan with rubber bumpers on garnish moldings & doors.....	35-36	125.00	kit
48-45983-2DB	1935-1936 tudor sedan with felt strips on garnish moldings and doors	35-36	125.00	kit
48-45983-5W/4DA	1935-1936 5-window coupe, fordor sedan with rubber bumpers on garnish moldings and doors	35-36	170.00	kit
48-45983-5W/4DB	1935-1936 5-window coupe, fordor sedan with felt strips on garnish moldings and doors	35-36	170.00	kit
50-45983-PUA	1935-1937 pickup with rubber bumpers on garnish moldings and doors	35-37	100.00	kit
50-45983-PUB	1935-1937 pickup with felt strips on garnish moldings and doors	35-37	125.00	kit



48-45983-5W/4DB

OPTIONAL STAINLESS STEEL BEAD

1932-1942 passenger and 1932-1947 pickups originally had a black bead on the edge of the channels and cat whiskers, our kits are made just like the originals. Kits may be ordered with a stainless steel bead in place of the black bead for an additional \$10.00. To order add **-SS** to the end of the part number. Note: 1946-1948 passenger and 1948-1952 pickups already come with stainless steel beading as original.

FRONT DOOR WINDOW CHANNEL KITS-continued

One kit services both doors. Made in U.S.A
1937-1940 Passenger & 1938-1941 Pickup

1937 – 1939

Includes the pre-bent one sided felt (cat whiskers), felted lower metal channels with clips attached, upper felt seal and installation screws. For customers wanting the original snap in clips used on the cat whiskers, order a separate clip kit part number 48-703536-A for the clips on the door body and 48-703536-B for the clips on the garnish molding.

78-45983-2D	1937-1939 tudor sedan and club coupe	37-39	125.00 kit
78-45983-5W/4D	1937-1939 5-window coupe, fordor sedan, sedan delivery	37-39	125.00 kit
81C-45983-PU	Pickup.....	38-39	125.00 kit

1940 Passenger & 1940-1941 Pickups

Includes all lower metal channels with brackets attached. the one sided felt strips (cat whiskers) are pre-bent and the original style "punch-in" attaching clips are included. Order the vent window edge seal separately, 01A-7022296 for closed cars & 01A-7022296-A for convertibles.

01A-45983-2D	Tudor sedan.....	1940	125.00 kit
01A-45983-5W/4D	5-Window coupe, fordor and sedan delivery.....	1940	110.00 kit
01C-45983-PU	Pickup.....	40-41	125.00 kit
01A-45983-C	Convertible.....	1940	90.00 kit



01A-45983-2D



01C-45983-PU



51A-45983-5W/4D

FRONT DOOR WINDOW CHANNEL KITS-continued

One kit services both doors. Made in U.S.A
1941-1948 Passenger & 1942-47 Pickup

1941-42 Passenger & 1942-1947 Pickups

The lower guide channel below the vent window has two variations. If you have the flat bracket with slots, use the kit with A at the end of the part number. If you have an angled bracket with threads use the kit with B at the end of the part number. Kit includes pre-bent one sided felt (cat whiskers), lower U-shape and metal channels, side straps, upper felt seal and installation clips. All 1941-1942 kits have a black bead on the cat whiskers as original. Order the vent window edge seal separately, 11A-7022296 for closed cars and 11A-7022296-A for convertibles. These 1941-1942 passenger car kits also fit Mercury.



Slotted holes



Threaded holes

11A-45983-2DA	1941-1942 tudor sedan, sedan coupe, large door, flat bracket with slotted hole	41-42	170.00 kit
11A-45983-2DB	1941-1942 tudor sedan, sedan coupe, large door, angled bracket with threaded holes.....	41-42	170.00 kit
11A-45983-5W/4DA	1941-1942 5-window coupe, fordor sedan, sedan delivery, small door, flat bracket with slotted holes	41-42	170.00 kit
11A-45983-5W/4DB	1941-1942 5-window coupe, fordor sedan, sedan delivery, small door, angled bracket with threaded holes	41-42	170.00 kit
21C-45983-PU	1942-1947 pickup	42-47	125.00 kit
11A-45983-C	Convertible	1941	110.00 kit
21A-45983-C	Convertible	42-48	90.00 kit

1946 – 1948 Passenger

For all 1946, 47, 48 coupe kits there are two different size coupe doors. For regular coupes with windows measuring 17-1/2" (small door) use the -5W/4D kit. For club/sedan coupes with windows measuring 26" use the -2D kit. All kits include pre-bent one sided felt (cat whiskers), lower U-shaped channels, side straps, division bar inner felt channel, upper felt seal and installation clips. All 1946-1948 kits have a stainless steel bead on the cat whiskers as original. Order the vent window edge seal separately, 51A-7022296 for closed cars & 11A-7022296-A for convertibles. These 1946-1948 passenger car kits also fit Mercury.

51A-45983-2D	1946-1948 tudor sedan, sedan coupe, large door.....	46-48	170.00 kit
51A-45983-5W/4D	1946-1948 coupe, fordor sedan, small door.....	46-48	125.00 kit
21A-45983-C	Convertible	42-48	90.00 kit

SEE NEXT PAGE FOR REAR QUARTER & REAR DOOR WINDOW CHANNEL KITS

REAR QUARTER WINDOW CHANNEL KITS - TUDOR

One kit services both rear quarter windows.

* Indicates the kit also fits Mercury. 1946-1948 kits have a stainless steel bead on the cat whiskers.

B-56786	Tudor sedan	32-33	110.00	kit
B-56786-V	Victoria	1932	90.00	kit
B-56786-400	B-400.....	1932	110.00	kit
40-56786	Tudor sedan & Victoria.....	1934	170.00	kit
48-56786-A	Tudor sedan with rubber bumpers on garnish moldings ..	35-36	125.00	kit
48-56786-B	Tudor sedan with felt strips on garnish moldings	35-36	125.00	kit
78-56786	Standard & tudor sedan.....	37-38	125.00	kit
81A-56786	1938 deluxe, 1939-1940 tudor sedan.....	38-40	130.00	kit
11A-56786*	Tudor sedan	41-42	125.00	kit
51A-56786*	Tudor sedan	46-48	125.00	kit

REAR DOOR WINDOW CHANNEL KITS - FORDOR

One kit services both rear doors. 40-56791 kits includes the one sided felts for the roll-up quarter windows.

* Indicates the kit also fits Mercury. 1946-1948 kits have a stainless steel bead on the cat whiskers.

B-56791	Fordor sedan and quarter windows.....	1932	110.00	kit
18-56791	Fordor sedan	1933	110.00	kit
40-56791-F	Fordor sedan with front mounted door handles.....	1934	170.00	kit
40-56791-C	Fordor sedan with center mounted door handles.....	1934	125.00	kit
48-56791-A	Fordor sedan with rubber bumpers on garnish moldings and doors	35-36	125.00	kit
48-56791-B	Fordor sedan with felt strips on garnish moldings & doors	35-36	125.00	kit
78-56791	Fordor sedan	37-38	125.00	kit
91A-56791	Fordor sedan	39-40	195.00	kit
11A-56791*	Fordor sedan	41-42	125.00	kit
51A-56791*	Fordor sedan	46-48	125.00	kit

BACK ROLL-DOWN WINDOW CHANNEL KITS

This kit services those cars that have a back window that rolls up & down.

A-46108	Coupe, 3 window, 5 window.....	30-34	60.00	kit
48-46108	Coupe, 3 window, 5 window.....	35-36	75.00	kit

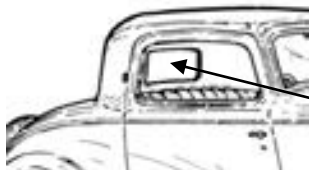

Rear window channel kit

DOOR GLASS BUMPERS

B-45830	Slanted glass anti-rattle, snaps on garnish molding.....	32-35	.25	ea
B-46044	Rounded glass anti-rattle, snaps on door frame.....	32-35	.25	ea
A-48141	Window cushion stop, rubber.....	32-34	1.00	ea
48-7821444	Garnish molding bumper, 5" long Cabriolet & convertible sedan only	32-35	4.00	ea



WINDOW CHANNEL FELT FASTNER KITS

Each kit contains 25 pcs., B-703536 is a good alternative for street rods and is black oxide coated so they will not be noticeable once installed on the one-sided felt.

B-703536	Screws, black oxide special small under-cut head kit.....	28-48	4.00	kit
48-703536-A	Punch in clip.....	35-40	7.50	kit
48-703536-B	Garnish molding clip	35-39	10.00	kit
78-703536	Staple.....	37-48	3.00	kit
11A-703536	V-clip.....	41-48	8.50	kit

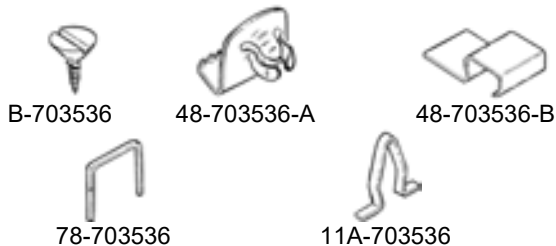

SEPARATE WINDOW CHANNEL STICKS

All sticks are 96" long.

* "Cat whiskers" are the one-sided strips generally used on garnish moldings.

** "U-shape" channels are generally used in division bars and guides for the glass to slide up and down in.

U-45983-1	Flexible, pile lining, black bead *	30.00	ea
U-45983-2	Flexible, pile lining, stainless bead *	30.00	ea
U-45983-3	Flexible, pile lining, black bead *	30.00	ea
U-45983-4	Flexible, pile lining, stainless bead *	30.00	ea
U-45983-5	Flexible, felt lining, no bead **	40.00	ea
U-45983-6	Flexible, pile & felt lining, no bead **	40.00	ea
U-45983-7	Flexible, pile lining, no bead **	40.00	ea
U-45983-8	Flexible, pile & felt lining, stainless bead **.....	40.00	ea
U-45983-20	Flexible, pile & felt lining, no bead, double U-shape, used on some station wagons for rear sliding windows	60.00	ea

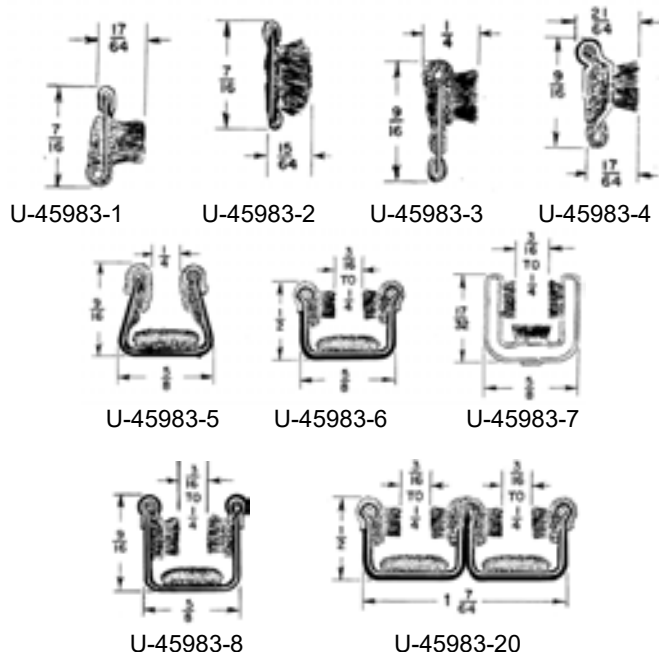

METAL GLASS CHANNELS

FRONT DOOR WINDOWS

- 46-45962 Pickup, right door 32-34 31.50 ea
- 46-45963 Pickup, left door 32-34 31.50 ea



- B-45962 Fordor & 5W coupe, cabriolet right door 1932 31.50 ea

- B-45963 Fordor, 5W coupe, cabriolet, left door 1932 31.50 ea



- 18-45962 3W coupe, right door 32-33 31.50 ea

- 18-45963 3W coupe, left door 32-33 31.50 ea



- B-55962 Tudor, right door 1932 31.50 ea

- B-55963 Tudor, left door 1932 31.50 ea



- 40-45962-A Fordor & 5W coupe, right door 1933 31.50 ea

- 40-45963-A Fordor & 5W coupe, left door 1933 31.50 ea



- 40-55962-A Tudor, right door 1933 31.50 ea

- 40-55963-A Tudor, left door 1933 31.50 ea



- 40-45962-B Fordor & 5W coupe, right door 1934 31.50 ea

- 40-45963-B Fordor & 5W coupe, left door 1934 31.50 ea



- 40-55962-B Tudor & 3W coupe, right door 1934 31.50 ea

- 40-55963-B Tudor & 3W coupe, left door 1934 31.50 ea

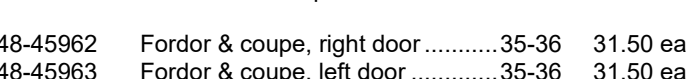

- 48-45962 Fordor & coupe, right door 35-36 31.50 ea

- 48-45963 Fordor & coupe, left door 35-36 31.50 ea



- 48-55962 Tudor, right door 35-36 31.50 ea

- 48-55963 Tudor, left door 35-36 31.50 ea



- 77-55962 Pickup, right door 35-37 31.50 ea

- 77-55963 Pickup, left door 35-37 31.50 ea



- 78-45962 Fordor & coupe, right door 37-39 31.50 ea

- 78-45963 Fordor & coupe, left door 37-39 31.50 ea



- 78-55962 Tudor & club coupe, right door 37-39 31.50 ea

- 78-55963 Tudor & club coupe, left door 37-39 31.50 ea



METAL GLASS CHANNELS

FRONT DOOR WINDOWS-continued

- 81C-55962 Pickup, right door 38-42 31.50 ea

- 81C-55963 Pickup, left door 38-42 31.50 ea



- 01A-45962 Fordor & coupe, 15", right door 1940 31.50 ea

- 01A-45963 Fordor & coupe, 15", left door 1940 31.50 ea



- 01A-55962 Tudor, 21", right door 1940 31.50 ea

- 01A-55963 Tudor, 21" left door 1940 31.50 ea



- 11A-45962 Fordor & business coupe, RH 41-48 31.50 ea

- 11A-45963 Fordor & business coupe, LH 41-48 31.50 ea



- 11A-55962 Club coupe (large door) and Tudor, 24 3/4", right door 41-48 31.50 ea

- 11A-55963 Club coupe (large door) and Tudor, 24 3/4" left door 41-48 31.50 ea



REAR QUARTER WINDOWS

- B-56787-A Tudor, RH passenger side 1932 31.50 ea

- B-56788-A Tudor, LH driver side 1933 31.50 ea

- B-56787-B Tudor, RH passenger side 1933 31.50 ea

- B-56788-B Tudor, LH driver side, 1933 31.50 ea

- 40-56787 Tudor, RH passenger side 34-40 31.50 ea



- 40-56788 Tudor, LH driver side 34-40 31.50 ea

- 11A-56787 Tudor, RH passenger side 41-48 31.50 ea

- 11A-56788 Tudor, LH driver side 41-48 31.50 ea

REAR DOOR WINDOWS

- B-56789 Fordor, RH passenger side 32-34 31.50 ea

- B-56790 Fordor, LH driver side 32-34 31.50 ea

- 48-56789 Fordor, RH passenger side 35-36 31.50 ea

- 48-56790 Fordor, LH driver side 35-36 31.50 ea

- 78-56789 Fordor, RH passenger side 37-40 31.50 ea

- 78-56790 Fordor, LH driver side 37-40 31.50 ea

- 11A-56789 Fordor, RH passenger side 41-48 31.50 ea

- 11A-56790 Fordor, LH driver side 41-48 31.50 ea

REAR ROLL DOWN GLASS CHANNEL

- B-47106 Rear roll down glass channel 32-36 9.00 ea



- 01A-7021470 Glass channel, plain, no brackets, for repair work, 36" long 28-53 40.00 ea



WIRING HARNESSSES

These harnesses are copies of original factory wiring with color coded cloth covered wire. Most of our harnesses come with wiring diagrams for ease of installation. Other wiring also available, see index for specific section or call for a more extensive list for your specific vehicle.

Wire connector sleeves and frame clips are not included and may be ordered as needed, see end of this section.



1932 PASSENGER CAR & PICKUP

- 18-11646 Headlight & tail light harness for vehicles **with** cowl lights 114.00 ea
- 18-11647 Headlight & tail light harness for vehicles **without** cowl lights..... 104.00 ea
- B-14302 Coil to distributor wire, 4 cylinder, 23.5" 12.75 ea
- B-14401 Dash harness, 4 cylinder..... 70.25 ea
- 18-14401 Dash harness, V8 77.50 ea
- B-14424 Taillight crossover wire for RH taillight 22.00 ea
- B-14426 Cowl light crossover wire for RH cowl light 16.00 ea

1933 - 1934 PASSENGER CAR & PICKUP

- 40-11646 Headlight & tail light harness for vehicles **with** cowl lights 100.00 ea
- 40-11647 Headlight & tail light harness for vehicles **without** cowl lights..... 106.00 ea
- 46-14401A Dash harness, 4 cylinder, 2 terminal amp gauge 109.50 ea
- 46-14401B Dash harness, 4 cylinder, loop style amp gauge 98.00 ea
- 40-14401A Dash harness, V8, 2 terminal amp gauge .. 83.00 ea
- 40-14401B Dash harness, V8, loop style amp gauge .. 81.75 ea
- B-14424 Taillight crossover wire for RH taillight 22.00 ea
- B-14426 Cowl light crossover wire for RH cowl light 16.00 ea
- 46-14436 Horn motor wire, 23" 13.00 ea

1935 - 1936 PASSENGER CAR & PICKUP

- 48-11647 Headlight & tail light harness..... 112.75 ea
- 68-14401 Dash harness, loop style amp gauge 108.75 ea
- B-14424 Taillight crossover wire 22.00 ea
- 68-14334C Dome light wire 40.00 ea
- 46-14436 Horn motor wire, 1935 passenger 23" 13.00 ea
- 68-14436A Horn motor wire, 1936 passenger 11" 9.00 ea
- 50-14436 Horn motor wire, pickup 30" 15.00 ea

1937 PASSENGER CAR & PICKUP

- 78-11653 Headlight harness 73.75 ea
- 78-14401A Dash harness, loop style amp gauge 123.00 ea
- 81A-14405 Body (taillight) harness 65.50 ea
- 81A-14405FP Body (taillight) harness as above .except wire added for electric fuel pump 74.00 ea
- B-14424 Taillight crossover wire for RH taillight 22.00 ea
- 68-14436A Horn motor wire, passenger 11" 9.00 ea
- 50-14436 Horn motor wire, pickup 30" 15.00 ea

1938 PASSENGER CAR

- 81A-11647 Headlight harness..... 120.50 ea
- 78-14335B Dome light to switch, 1 wire, 80" 12.00 ea
- 81A-14401B Dash harness with cutout, loop style amp gauge..... 91.00 ea
- 81A-14401C Dash harness with voltage regulator 194.00 ea
- 81A-14405 Body (taillight) harness 65.25 ea
- 81A-14405FP Body (taillight) harness as above .except wire added for electric fuel pump..... 65.50 ea
- 91A-14415 License light wire, 2 pieces 13.00 ea
- 81A-14419 Fuse block to coil..... 44.50 ea
- 81A-13412 License light wire, 10" 3.75 ea
- B-14424 Taillight crossover wire for RH taillight..... 22.00 ea

1938 PICKUP

- 81C-11647 Headlight harness..... 111.00 ea
- 81A-14401B Dash harness with cutout, loop style amp gauge..... 91.00 ea
- 81A-14401C Dash harness with voltage regulator 194.00 ea
- 81A-14405 Body (taillight) harness 65.25 ea
- 81A-14405FP Body (taillight) harness as above .except wire added for electric fuel pump..... 74.00 ea
- 81A-14419 Fuse block to coil..... 44.50 ea
- B-14424 Taillight crossover wire for RH taillight..... 22.00 ea
- 68-14436A Horn motor wire 11" 9.00 ea

1939 PASSENGER CAR

- 91A-11653A Headlight harness, Standard 109.50 ea
- 91A-11653B Headlight harness, Deluxe 106.50 ea
- 91A-14334B Dome light wire, 1 wire, 60 " 7.25 ea
- 78-14335B Dome light to switch, 1 wire, 80" 12.00 ea
- 91A-14401C Dash harness, 3 brush generator, Standard, loop style amp gauge & voltage regulator 157.00 ea
- 91A-14401 Dash harness, Standard with 3 brush generator cut-out, loop style amp gauge . 161.25 ea
- 91A-14401D Dash harness, Deluxe with voltage regulator & 2 brush generator..... 157.00 ea
- 91A-14405 Body (taillight) harness 67.25 ea
- 91A-14415 License light wire, includes socket wire 81A-13412 13.00 ea
- B-14424 Taillight crossover wire for RH taillight..... 22.00 ea
- 09B-14436 Horn motor wires, 2 pieces, 11" & 9 6.50 ea
- 91A-18457 Heater motor wire 27.00 ea

1939 PICKUP

- 91C-11653 Headlight harness..... 104.00 ea
- 91C-14401A Dash harness, 3 brush generator, loop style amp gauge 172.50 ea
- 91C-14401B Dash harness, 2 brush generator using volt gauge 130.00 ea
- 91C-14401C Dash harness, 2 brush generator, loop style amp gauge 193.75 ea
- 91A-14405 Body (taillight) harness 67.25 ea
- B-14424 Taillight crossover wire 22.00 ea
- 68-14436A Horn motor wire 11" 9.00 ea



1940 PASSENGER CAR

01A-11652K	Headlight switch wire	14.50 ea
01A-11653A	Headlight harness, Standard & Deluxe	96.00 ea
01A-13506	Trunk light socket wire, 12" coupe & convertible only	10.50 ea
91A-14334B	Dome light wire, 1 wire, 60 ".....	7.25 ea
78-14335B	Dome light to switch, 1 wire, 80"	12.00 ea
01A-14401B	Dash harness, Standard & Deluxe	176.50 ea
91A-14405	Body (taillight) harness	67.25 ea
91A-14415	License light wire, includes socket Wire 81A-13412	13.00 ea
B-14424	Taillight crossover wire for RH taillight	22.00 ea
09B-14436	Horn motor wires, 2 pieces, 11" & 9.....	6.50 ea
91A-18457	Heater motor wire	27.00 ea

1940 PICKUP

01A-11652K	Headlight switch wire	14.50 ea
01C-11653	Headlight harness	83.50 ea
01C-14401B	Dash harness.....	179.00 ea
91A-14405	Body (taillight) harness	67.25 ea
B-14424	Taillight crossover wire for RH taillight	22.00 ea
68-14436A	Horn motor wire 11"	9.00 ea
09B-14436	Horn motor wires, 2 pieces, 11" & 9.....	6.50 ea

1941 - 1942 PASSENGER CAR

11A-11652K	Headlight switch wire	41-42	18.75 ea
11A-11653	Headlight harness	1941	103.75 ea
51A-11653A	Headlight harness,	1942	97.25 ea
11A-13842D	Horn to relay wires, 10".....	41-42	9.75 ea
21A-14302	Coil to distributor wire, V8, 27"	1942	7.25 ea
11A-14305A	Generator to regulator wire, V8.....	41-42	37.50 ea
11A-14308	Horn button wire, 62".....	1941	6.50 ea
21A-14308	Horn button wire, Deluxe & Special, less rivet & plug, 62".....	1942	6.50 ea
11A-14322	Oil sender to cowl wire, V8, 8"	41-42	7.00 ea
1GA-14322	Oil sender to cowl wire, V8, 32"	41-42	19.25 ea
11A-14334B	Dome light switch to fuse block.....	41-42	12.75 ea
11A-14335B	Dome light to switch, 74".....	41-42	8.50 ea
11A-14339	Convertible top wire	41-42	168.75 ea
11A-14401	Dash harness.....	1941	190.50 ea
21A-14401	Dash harness, column ignition	1942	198.00 ea
11A-14405A	Body (taillight) harness, Deluxe, Super Deluxe & Mercury	41-42	88.00 ea
51A-14405B	Body (taillight) harness, Special & station wagon	41-42	130.00 ea
11A-14415A	License light wire extension 38" Tudor & Fordor Sedan	1941	12.00 ea
11A-14415B	License light wire extension, 53" use with 11A-14415A	1941	12.00 ea
11A-14415C	License light wire extension 53" Coupe & Convertible	1941	12.00 ea
11A-14415B	Trunk light & license light wire extension 53" Sedan	1941	12.00 ea
51A-14432	Temperature sender wire, 15".....	41-42	6.50 ea
09B-14436	Horn motor wires, 2 pcs, 11" & 9".....	41-42	6.50 ea
11A-18457	Heater motor wire	1941	27.00 ea
21A-18457	Heater motor wire	1942	25.00 ea

1941 - 1942 PICKUP

11A-11652K	Headlight switch wire	41-42	18.75 ea
01C-11653	Headlight harness	41-42	83.50 ea
21A-14302	Coil to distributor wire, V8 , 27"	1942	7.25 ea
11A-14305A	Generator to regulator wire, V8.....	41-42	37.50 ea
11C-14401B	Dash harness, V8	41-42	192.75 ea
11C-14405A	Body (taillight) harness	1941	86.00 ea
21C-14405A	Body (taillight) harness	1942	62.00 ea
B-14424	Taillight crossover wire	41-42	22.00 ea
51A-14432	Temperature sender wire, 15".....	41-42	6.50 ea
68-14436A	Horn motor wire 11"	41-42	9.00 ea

1946, 1947, 1948 PASSENGER CAR

11A-11652K	Headlight switch wire	46-48	18.75 ea
51A-11653A	Headlight harness, use with 21A-14401 & 11A-14305A. Cars with horns behind radiator...	46-47	97.25 ea
21A-14401	Dash harness, use with 51A-11653A	46-47	198.00 ea
11A-14305A	Generator to regulator wire, V8 ...	46-47	37.50 ea
51A-11653B	Headlight harness, use with 51A-14401A. Cars with horns in front of radiator	47-48	45.00 ea
51A-14401A	Dash harness	47-48	296.50 ea
11A-13842D	Horn to relay wires, 10"	46-47	9.75 ea
21A-14302	Coil to distributor wire, V8, 27".....	46-48	7.25 ea
11A-14308	Horn button wire, Super Dlx, 62"	46-48	6.50 ea
21A-14308	Horn button wire, Deluxe & Special, less rivet & plug, 62"	46-48	6.50 ea
11A-14322	Oil sender to cowl wire, V8, 8"	46-48	7.00 ea
1GA-14322	Oil sender to cowl wire, V8, 32" ...	46-48	19.25 ea
11A-14334B	Dome light switch to fuse block ...	46-48	12.75 ea
11A-14335B	Dome light to switch, 74"	46-48	8.50 ea
11A-14339	Convertible top wire	46-48	168.75 ea
51A-14405A	Body (taillight) harness, Deluxe, Super Deluxe & Mercury, exc wagon	46-48	88.00 ea
51A-14405B	Body (taillight) harness, Special & station wagon	46-48	130.00 ea
11A-14415A	License light wire extension 38" Tudor & Fordor Sedan	46-48	12.00 ea
11A-14415B	License light wire extension, 53" Sedans, use with 11A-14415A ...	46-48	12.00 ea
11A-14415C	License light wire extension 53" Coupe & Convertible	46-48	12.00 ea
51A-14414	License light wire extension, 61" Cpe & Conv use with 11A-14415C ...	46-48	14.00 ea
51A-14432	Temperature sender wire, 15"	46-48	6.50 ea
09B-14436	Horn motor wires, 2 pcs, 11" & 9"...	46-47	6.50 ea
21A-18457	Heater motor wire	1946	25.00 ea
51A-18457	Heater motor wire	47-48	28.25 ea

1946, 1947 PICKUP

11A-11652K	Headlight switch wire	46-47	18.75 ea
01C-11653	Headlight harness.....	46-47	83.50 ea
21A-14302	Coil to distributor wire, V8 , 27"	46-47	7.25ea
11A-14322	Oil sender to cowl wire, V8, 8"	46-47	7.00 ea
51C-14401A	Dash harness, V8	46-47	204.00 ea
21C-14405A	Body (taillight) harness	46-47	62.00 ea
81W-14406	Fuel sending unit wire, pickup	42-47	8.00 ea
B-14424	Taillight crossover wire	46-47	22.00 ea
51A-14432	Temperature sender wire, 15"	46-47	6.50 ea
68-14436A	Horn motor wire 11"	46-47	9.00 ea

WIRE CONNECTORS & FRAME CLIPS

B-14486	Male connector for 16-18 gauge wire.....	32-48	.40 ea
B-14487	Wire connector sleeve for above	32-48	.45 ea
59A-14487	Double splice or 4 way wire (up to 16 gauge) connector sleeve ...	32-48	2.25 ea
81A-14486	Male connector, large size for 12-14 gauge wire.....	32-48	.50 ea
81A-14487	Wire connector sleeve, large Size, 12-14 gauge wire	38-46	2.75 ea

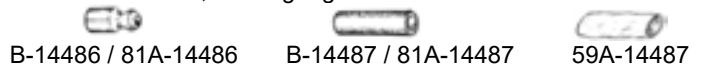

B-14486 / 81A-14486	B-14487 / 81A-14487	59A-14487
---------------------	---------------------	-----------

ORDER & INFORMATION LINE 1- 508-278-3980 TOLL FREE 1-800-508-3980 Email: joesantique@charter.net

WIRING CLIPS

B-14585-S	Wiring clip, small, set of 10 pieces...	32-48	4.00 set
B-14585-L	Wiring clip, large, set of 10 pieces...	32-48	4.00 set
A-14577-A	Wiring clip with hole	32-48	2.00 ea



B-14585



A-14577-A

CLOTH WIRE

16 gauge cloth covered wire, sold by the foot

CLOTHWIRE/BLK	Black	0.75 foot
CLOTHWIRE/GRN	Green	0.75 foot
CLOTHWIRE/RED	Red	0.75 foot
CLOTHWIRE/YLW	Yellow	0.75 foot
CLOTHWIRE/BLU	Blue	0.75 foot



FLEXIBLE WIRE LOOM

A black flexible cloth conduit used in various places throughout the car.

A-14407-1/4	1/4" ID, per foot	1.50 ft
A-14407-1/4-R	1/4" ID, 25 foot roll	35.00 roll
A-14407-5/16	5/16" ID, per foot	1.50 ft
A-14407-5/16-R	5/16" ID, 25 foot roll	35.00 roll
A-14407-1/2	1/2" ID, per foot	1.50 ft
A-14407-1/2-R	1/2" ID, 25 feet	35.00 roll



BATTERY TO STARTER (-NEGATIVE) CABLES

18-14195	26.5" long	32-34	19.00 ea
48-14300	27.5" long	35-36	18.00 ea
48-14300-B	With 48-14550 bracket, installed 27.5" long	35-36	30.00 ea



18-14195



48-14300

STARTER CABLE BRACKETS & GROMMET

18-14550	RH & LH bracket with grommet...	32-34	18.00 pr
48-14550	1933-1936 passenger and 1948-1956 pickup, bracket with grommet	33-56	8.50 ea
18-14548	1932-1936 passenger & 1948-1956 pickup, grommet only	32-56	3.00 ea



18-14550 LH & RH



48-14550

BATTERY TO SOLENOID (-NEGATIVE) CABLES

78-14300	17.5" long 1937-39 Cars exc 38 Dix & 1938-39 pickups	37-39	19.75 ea
91A-14300	1938 Dix, 1939-48 Cars, 1940-47 pickups, 13.5" long	39-48	22.50 ea
1GA-14300	Passenger, 6 cylinder, 30" long	41-47	30.00 ea
8A-14300	Passenger, 17.25" long	49-51	20.00 ea



BATTERY CABLE HOLDER & GROMMET

B-14434	Rubber frame grommet. Fits in 1.25" diameter hole	32-34	5.00 ea
48-14433	Script, mounts at transmission	35-37	5.50 ea



B-14434



48-14433

STARTER SWITCH TO STARTER CABLES

18-14431	30.5" long	32-36	14.50 ea
B-14431	4 cylinder, 8.25" long	32-34	13.75 ea



SOLENOID TO STARTER CABLES

78-14431	18" long	37-48	13.50 ea
8A-14431	47.5" long	49-51	14.25 ea



BATTERY TO GROUND (+POSITIVE)

40-14301	1932-1934, 19" long	32-34	13.00 ea
48-14301	11.5" long	35-36	13.00 ea
78-14301	9.75" long	37-39	13.00 ea
91A-14301	7.5" long	39-48	13.00 ea
8BA-14301	24.0" long	49-53	15.50 ea



ENGINE TO FIREWALL (GROUND STRAP)

91A-14303	8.25" to hole centers	37-48	7.00 ea
78-14303	9.5" to hole centers	37-48	8.50 ea

Note: Length in Ford green book stated as 9"



BATTERY DISCONNECT SWITCH

A-14300-C terminal mount switch attaches directly to battery post and requires no modification to install. A-14300-D and SR-14300 permanent mount switches require some installation, but are more convenient to use. SR-14300 is molded plastic with a red removable "key".

A-14300-C	Terminal mount, brass	10.00 ea
A-14300-D	Permanent mount, metal	25.00 ea
SR-14300	Removable key type, plastic	12.00 ea

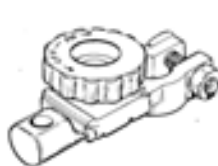

A-14300-C



A-14300-D

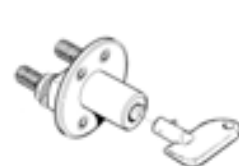

SR-14300

FIREWALL INSULATORS – ONE PIECE DESIGN

These insulators are molded with a tough ABS plastic textured panel with attached insulation material to fit over transmission & firewall curves. Insulators are shipped ready to install, no cutting required. Made from originals to look & fit like originals

B-700770-1	4 Cylinder, Model B car and pickup, requires 12 studs...	1932	280.00	ea
18-700770-1	V8 car & pickup, requires 12 studs.....	1932	280.00	ea
40-700770-1	V8 or 4 cyl, car, requires 12 studs.....	33-34	280.00	ea
46-700770-1	V8, pickup, requires 12 studs...	33-34	280.00	ea
48-700770-1	Car, requires 11 studs.....	35-36	270.00	ea
50-700770-1	Pickup, requires 15 studs.....	35-36	280.00	ea
78-700770-1	1937-1938 car & 1939 Standard car, requires 10 studs.....	37-39	270.00	ea
75-700770-1	Pickup, requires 12 studs.....	37-39	270.00	ea
91A-700770-1	Deluxe car, requires 10 studs...	1939	270.00	ea
99A-700770-1	Mercury, requires 12 studs.....	1939	280.00	ea
01A-700770-1	Car, requires 8 studs.....	1940	270.00	ea
01C-700770-1	Pickup, requires 11 studs.....	40-47	230.00	ea
11A-700770-1	Car, requires 8 studs.....	1941	230.00	ea
21A-700770-1	Car, requires 8 studs.....	42-48	230.00	ea

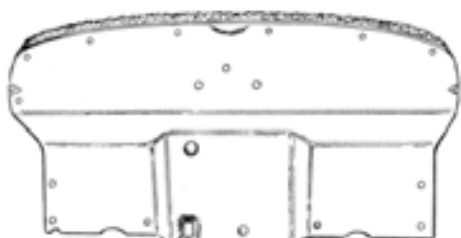
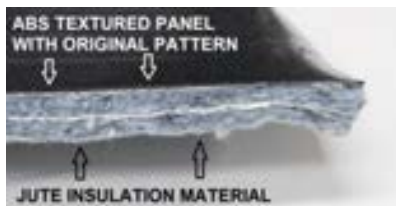

One piece firewall insulator

FIREWALL INSULATOR STUDS

Holds above insulators in place.

48-7001670-B	Original style metal studs.....	35-48	4.00	ea
390018-S	Plastic replacement type.....	35-48	2.00	ea



48-7001670-B



390018-S

FRONT FLOORBOARDS

18-700325	Cars, 2 pieces.....	1932	ASK
B-700325	Pickup & station wagon.....	1932	ASK
40-700325	Cars.....	33-34	ASK
46-700325	Pickups.....	33-34	ASK
48-700325	Cars.....	1935	ASK
68-700325	Cars.....	1936	ASK
50-700325	Pickups.....	35-36	ASK
78-700325	Cars.....	1937	ASK
81A-700325	Cars.....	1938	ASK
91A-700325	Cars.....	1939	ASK
75-700325	Pickups.....	37-39	ASK
01A-700325	Cars.....	1940	ASK

INSULATION ROLLS

These insulation materials have reflective aluminum foil. Rolls with jute or fiberglass insulation (HR-700770 or B-5010-FG) ideal for use in firewalls, kick panels, rumble seat panels & under carpeting. Rolls with polyethylene bubble (SR5010-5) can also be used in these areas but especially recommended for doors or below roll down windows.

HR-700770	Jute padding material, rated R3 (700 f resistance). Foil bonded one side. Requires adhesive for installation. 48" wide x 72" long x 5/16" thick.....	35.00	ea
B-5010-FG	Fiberglass padding material. Aluminum Foil bonded one side. Adhesive back. 40" wide x 96" long.....	45.00	roll
SR-5010-5	Polyethylene bubble film sandwiched between two layers of aluminum foil. (180 f resistance). 48" wide x 72" long x 1/4" thick. Requires adhesive.....	25.00	roll

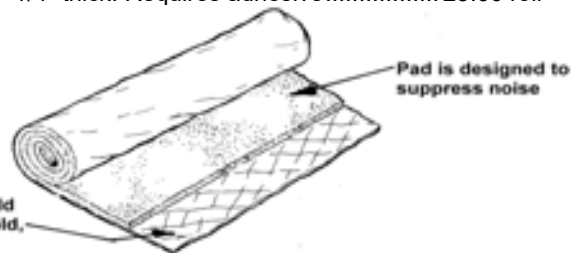

HR-700770 / B-5010-FG

FOIL INSULATION SHEETING

This insulation used inside doors, floors or behind headliners. Works great at insulating from heat, cold and sound. Wear resistant and waterproof. Layer include foil, tar saturated type pad and adhesive backing.

B-5010-F	36" wide x 50" long, by Drake.....	ASK
DYNAMAT	18" X 32" sheet, Xtreme brand.....	ASK



DYNAMAT

BODY INSULATION SHEETING-WAFFLE PATTERN

Exact waffle pattern as original. Tar saturated water resistant material. Used for insulating many areas of the inner body including the trunk lid. Works great on hushing road noise and vibrations. Can be shaped to fit with a heat gun.

B-5010-F30	3/32" thick x 3 ft wide x 8 ft long.....	90.00	roll
B-5010-F31	1/8" thick x 3 ft wide x 8 ft long.....	100.00	roll

BODY INSULATION SHEETING

Tar saturated water resistant material. Used for insulating many areas of the inner body.

B-5010-F30-P	1/16" thick x 3 ft wide x 8 ft long.....	12.00	roll
--------------	--	-------	------

FLOORBOARD SCREW KITS

A-80028-B	12-24 x 1 1/4" long, 12 screws and 12 special washers.....	28-32	7.00	kit
40-80028-C	1/4" -20 x 1 1/4" long, 14 screws and 14 washers.....	33-40	7.00	kit



BATTERY COVERS

48-7000336 Stamped steel, car & pickup.....35-36 50.00 ea



48-7000336

STEERING TUBE & PEDAL SEALS

B-7001730 Pedal & steering tube seal, passenger & pickup, sponge rubber, car & pickup 1932 10.00 ea

40-7001730 Pedal & steering tube seal, car, sponge rubber33-34 10.00 ea



B-7001730

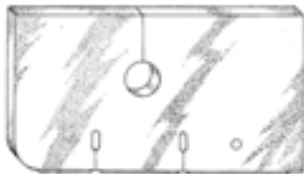

40-7001730

48-7001730 Pedals, steering tube & starter button seal kit, car, sponge rubber, 4 pieces.....35-38 10.00 set



48-7001730

91A-2476/7527 Pedal seal, 1939-1948 car & 1939-1947 pickup, sponge rubber, 2 pieces.....39-48 6.00 pr

01A-7001731 Steering tube seal, passenger, sponge rubber, car 1940 5.00 ea



91A-2476/7527



01A-7001731

11A-7001730 Steering tube seal, Ford and Mercury car, on top of floor mat, molded rubber41-48 8.00 ea

11A-7001731 Steering tube seal, Ford car, fits below floor mat, Sponge rubber.....41-48 15.00 ea

19A-7001731 Steering tube seal, Mercury car, below floor mat, sponge rubber.....41-48 15.00 ea



11A-7001730



11A-7001731
19A-7001731

STEERING TUBE & PEDAL FLOOR PLATES

Stamped steel

B-35122-ST Steering tube & pedal plate, car & pickup, 2 pieces..... 1932 25.00 ea

40-700392 Steering tube & pedal plate, car..... 33-34 ASK



B-35122

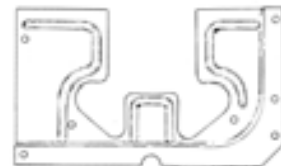

40-700392

48-700392 Pedal plate, car..... 35-36 23.00 ea

68-700392 Pedal plate, car..... 1936 23.00 ea



48-700392



68-700392

01A-7001732/5 Steering tube plates, car..... 1940 N/A

01C-8112145 Steering tube & pedal plate, pickup40-41 25.00 ea

**N/A is not available at time of this printing, please inquire.*



01A-7001732/5



01C-8112145

TRANSMISSION TOP FLOOR SEAL

B-7012130 Transmission floor seal, car & pickup, sponge rubber 1932 10.00 ea

40-7012130 Transmission floor seal, car, sponge rubber..... 33-36 10.00 ea

78-7012130 Transmission floor seal, car, sponge rubber..... 37-39 10.00 ea

51C-8112130 Transmission floor seal, pickup, sponge rubber..... 42-47 10.00 ea



B-7012130



40-7012130



78-7012130



51C-8112130

GAS TANK SENDER HOLE COVERS

Die formed steel with hold down screw

48-700262 Passenger cars 35-36 16.00 ea

78-700262 Passenger cars 37-41 16.00 ea



48-700262



78-700262

FLOORBOARD SEALS 1932-1935

Seals floorboards to metal.

A-35130-S	(1) roll 120" long woven lacing and package of tacks	32-34	10.00 kit
48-700364-B	(2) rolls 60" long x 1 1/2" wide x 3/16 thick felt for RH and LH Car	1935	15.00 kit



A-35170-AS



48-700364-B

FLOORBOARD SEALS 1936-1948

Seals floor wood to metal.

68-700364/5	Passenger, RH & LH, molded sponge rubber	1936	ASK
78-700364/5	Passenger, RH & LH, molded sponge rubber, includes seal at steering tube.....	37-38	ASK
91A-7011508/9	Deluxe & standard, RH & LH, molded sponge rubber, includes seal at steering tube ...	1939	ASK



78-700364/5



91A-7011508/9

01A-7011508/9	Deluxe & standard, RH & LH..	1940	80.00 set
11A-7011508/9	Passenger, RH & LH, sponge rubber extrusion	41-48	N/A



01A-7011508/9



11A-7011508/9

RUBBER FLOOR PLUGS

Fits between floor & frame.

11A-5015-S	Passenger, 4 pieces	41-48	6.00 set
------------	---------------------------	-------	----------



TRANSMISSION FLOOR COVERS

Die stamped steel.

40-700380	Cars, stock design with holes cutout for shift lever & brake	33-34	120.00 ea
40-700380-P	Cars with no holes	33-34	120.00 ea
67-810380	Pickups	35-39	75.00 ea
4047TC	Pickups	40-47	80.00 ea
01A-7012108	1940 cars & 37-39 cars if hole cut for shift lever	37-40	150.00 ea

Transmission Floor Cover

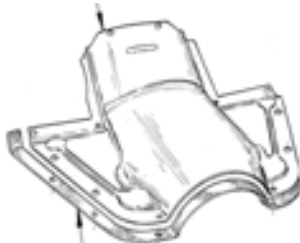

Floor Seal

TRANSMISSION COVER FLOOR SEAL & SCREW KIT

78-7012125	Floor seal, passenger	37-40	8.00 pr
01C-8112125	Floor seal, pickup	40-47	15.00 pr
40-80030-A	Screw kit	33-34	6.00 kit
68-80030-B	Screw kit	35-36	4.00 kit
78-80030-C	Screw kit	37-40	4.00 kit

FRONT RUBBER FLOOR MATS

1935-48 mats include insulating jute pads. Die cut holes for shifter tower and brake pedals. (Except as noted)

Cars

4005-7013000-T	Car, taupe.....	1932	180.00 ea
4003-7013000-B	Car, black, 2 piece.....	33-34	175.00 ea
4003-7013000-T	Car, taupe, 2 piece	33-34	180.00 ea
4001-7013000-B	Car, black	35-36	150.00 ea
4000-7013000-T	Car, Benton grey	35-36	180.00ea
4007-7013000-B	Car, black	37-39	150.00 ea
4013-7013000-T	Car, Benton grey	37-39	180.00 ea
4008-7013000-B	Car, black	1940	150.00 ea
4014-7013000-T	Car, Benton grey	1940	180.00 ea
4010-7013000-B	Car, black	41-48	150.00 ea



Typical Black Floor Mat



4003-7013000-T

Pickups

81C-7013000	Pickup, black –no cut holes * ...	38-47	140.00 ea
01C-7013000	Pickup, black.....	40-41	140.00 ea
21C-7013000	Pickup, black.....	42-47	140.00 ea

** Can be modified to fit earlier pickups, big trucks & and for custom applications*

REAR SEAT MATS

68-7013001-T	Phaeton, tan *	1936	N/A
--------------	----------------------	------	-----

** Will work in 1935 Phaeton but not correct pattern*

RUMBLE SEAT MATS

40-7013002-T	Taupe.....	33-34	180.00 ea
68-7013002-T	Benton grey.....	1936	180.00 ea
78-7013002-T	Benton grey.....	36-39	180.00 ea

TRUNK MATS

2532-7245462	Coupe & convertible, black	38-40	140.00 ea
2533-7045462	Sedan, black	38-40	140.00 ea
2536-7645462	Convertible, black	41-48	155.00 ea
2537-7245462	Coupe, black.....	41-48	140.00 ea
2538-7045462	Sedan, black	41-48	140.00 ea

FLOOR MAT CLIP

B-20018	Brown head	32-34	1.00 ea
48-20018	Black head.....	35-40	1.00 ea



B-20018



48-20018

WIPER HOSE GROMMETS-CHROME

B-17511 Roadster & phaeton fits by windshield post on body..... 32-37 5.00 ea



FIREWALL RUBBER GROMMETS-Complete Sets

B-14600-S Firewall grommet set, 11 pieces .. 1932 13.50 set
 40-14600-S Firewall grommet set, 5 pieces 33-34 15.00 set



B-14600-S



40-14600-S

FIREWALL RUBBER GROMMETS-Individual

B-14603 Wire loom grommet (included in B-14600-S above) (Fits 1" dia hole) 1932 1.50 ea
 40-14603 Wire loom grommet (included in 40-14600-S above) 33-34 1.50 ea



B-14603



40-14603

B-14605 Choke & throttle grommet at firewall (included in B- & 40-14603 above) (Fits 5/8" diameter hole)... 32-48 2.00 ea
 B-14605 Hood pull cable grommet 41-48 2.00 ea
 48-14603 Wire loom grommet..... 35-48 5.00 ea



B-14605



48-14603

B-17265 Speedometer grommet (included in B-700731 above) (Fits 1 1/8" diameter hole)..... 1932 1.50 ea
 40-17265 Speedometer grommet (Fits 3/4" diameter hole)..... 33-39 1.50 ea



B-17265



40-17265

01A-17265 Emergency brake & speedometer cable firewall grommet. 1940 car 1940-41 pickup 40-41 6.00 ea



01A-17265

FIREWALL RUBBER GROMMETS-continued

11A-17265 Emergency brake & speedometer cable firewall grommet car..... 41-48 6.00 ea



11A-17265

21C-17265 Speedometer cable & wiper hose firewall grommet, pickups only..... 42-47 6.00 ea



21C-17265



91A-17545

01A-17545-B Wiper hose grommet, 1939-1948 car & 1940-41 pickup , fits 1" diameter hole..... 40-48 4.00 ea



01A-17545-B

CHOKE & THROTTLE DASH GROMMETS

B-9719 Black, rubber..... 32-37 1.50 ea
 40-9719 Brown, rubber 32-37 1.50 ea
 48-9719 Gray, rubber..... 35-36 1.50 ea
 91A-9719 Grommet & clip set, 4 pieces ... 39-48 24.50 set
 81A-9719 1938-1940 passenger & 1940-1941 pickup, black, rubber, replacement for 91A-9719-B.... 38-41 7.00 pr



B-9719 40-9719 48-9719

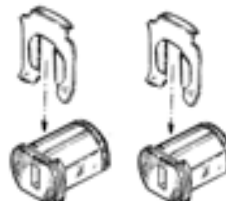

91A-9719



81A-9719

HEADLIGHT WIRE GROMMETS

8C-13078 Fits in 5/8" diameter hole 39-48 4.00 ea
 51A-13077 Fits in 7/8" diameter hole 39-48 2.00 ea
 B-14603 Fits 1" diameter hole..... 39-48 1.50 ea



8C-13078 & B-14603



51A-13077

FRAME REPAIR COMPONENTS

Includes button head screws with nuts for installation

- PC 82 Cross member, LH, frame outer rail to X - member.....35-36 130.00 ea
- PC 83 Cross member, RH, frame outer rail to X - member,35-36 130.00 ea
- 68-5153 Battery support, front.....35-36 26.00 ea



PC82 68-5153

Below components also fits 1941 pickups

- PC 80 Crossmember, LH, frame outer rail to X - member,37-40 130.00 ea
- PC 81 Crossmember, RH frame outer rail to X - member,37-40 130.00 ea



PC80 PC81

- PC 78 Frame repair section with correct bend radius, 11 ga. 36" long.....35-40 36.00 ea



PC78

- PC 100 Rear cross member.....35-40 85.00 ea



PC100

- PC 106 Frame section, LH, rear with appropriate holes and cage nut, 11 guage. 35 1/2" long 35-40 130.00 ea
- PC 107 Frame section, RH, rear with appropriate holes and cage nut, 11 guage. 35 1/2" long 35-40 130.00 ea



PC106

PC107

- PC 110 X - member repair section, LH..... 35-40 165.00 ea
- PC 111 X - member repair section, RH, 35-40 165.00 ea



PC110

PC111

- PC 64 Body mount, left front..... 35-40 125.00 ea
- PC 65 Body mount, right front..... 35-40 125.00 ea
- PC 71 Body mount, left rear..... 35-40 120.00 ea
- PC 72 Body mount, right rear..... 35-40 120.00 ea
- P507 Body mount, complete set of above (4)..... 480.00 set



PC64

PC65

PC71

PC72

FLOOR STIFFENERS/SEAT MOUNTS

- PC92 Front seat mount, LH..... 1940 60.00 ea
- PC93 Front seat mount, RH 1940 60.00 ea
- PC94 Rear seat mount, LH 1940 55.00 ea
- PC95 Rear seat mount, RH..... 1940 55.00 ea



PC92

PC94

FRAME REPAIR COMPONENTS

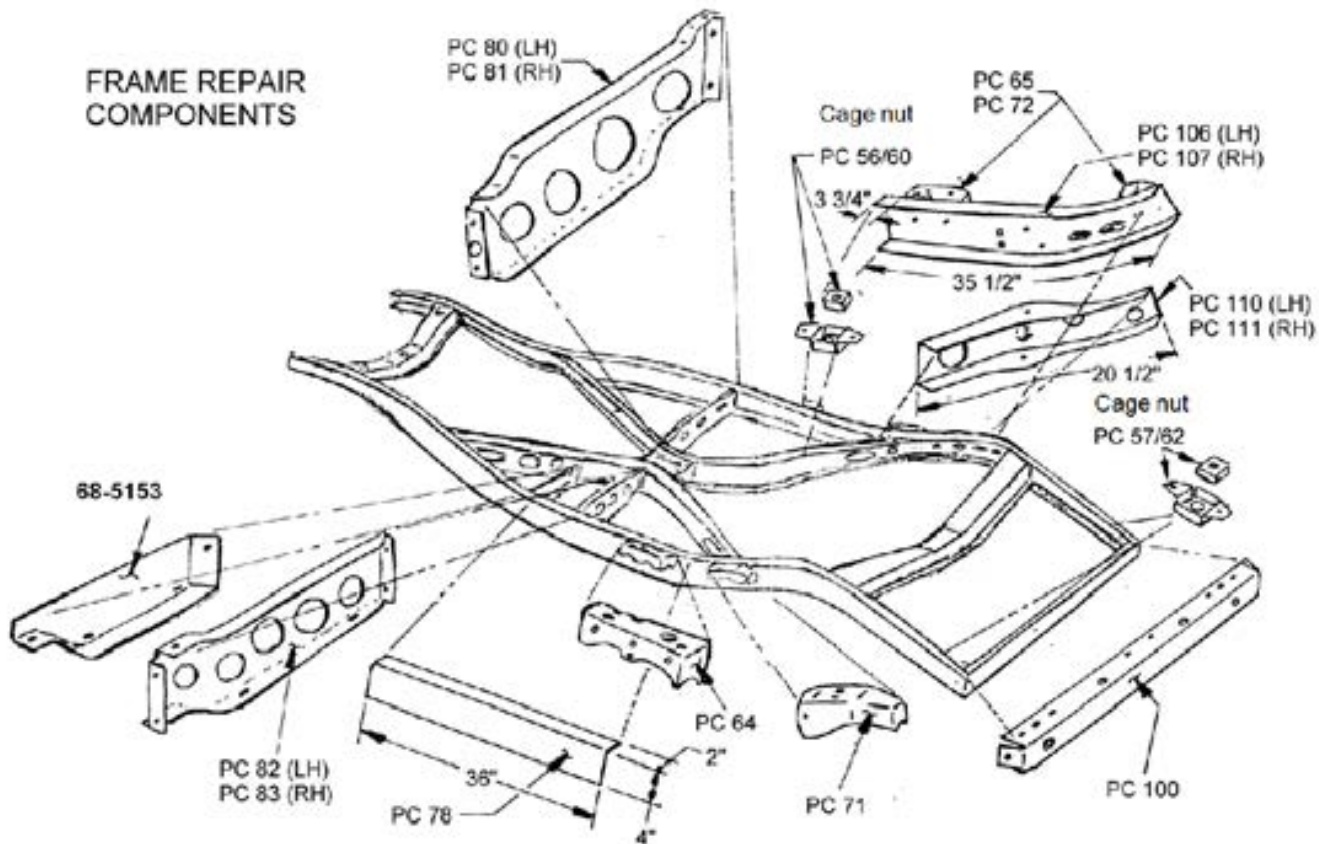

COMPLETE PICKUP BEDS

These pickup beds are available either assembled or as an unassembled kit. 1932-37 unassembled kits have no instructions and require auto body experience along with an original bed to be used as a pattern for assembly. 1938-47 beds do have assembly instructions.

Included are all components for a complete bed except for the lower bed sides and mounting hardware (available at extra cost). All beds supplied with oak wooden bed floor and plain steel bed strips & hardware (stainless optional). Beds also available with stock steel floors, please inquire if additional charge is needed.

Available either with or without stake pockets holes and some beds welded instead of riveted. Please call for shipping costs and delivery times.

Part No	Unassembled Kit	Part No	Assembled Unit
1932BED-U	2,200.00	1932BED-A	2,800.00
3234BED-U	2,200.00	3234BED-A	2,800.00
3536BED-U	2,200.00	3536BED-A	2,800.00
1937BED-U	2,200.00	1937BED-A	2,800.00
3841BED-U	2,200.00	3841BED-A	2,800.00
4247BED-U	2,200.00	4247BED-A	2,800.00

Above bed strips & hardware are plain steel. For stainless strips and hardware add \$230.00 and -SS to part no.

Add \$125.00 crating charge to above prices. Shipped by truck freight & cost provided upon request.



PICKUP TAILGATES

18-10137	Die stamped, late 1931-1934 ...	31-34	300.00 ea
50-10138	Die stamped, Ford script	35-36	300.00 ea

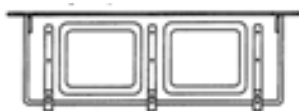

18-10137

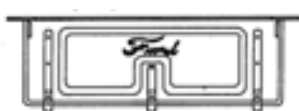

50-10138

77-10139	Die stamped, Ford script	1937	300.00 ea
81C-10140	Die stamped, Ford script	38-40	325.00 ea



77-10139



81C-10140

11C-10141	Die stamped, Ford script	1941	325.00 ea
21C-10142	Die stamped, Ford script	42-50	325.00 ea



11C-10141

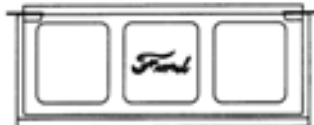

21C-10142

PICKUP BED FRONT PANELS

18-10757	Die stamped, 46" wide	32-37	190.00 ea
81C-10758	Die stamped, 46" wide	38-41	150.00 ea
21C-10759	Die stamped, 49" wide	42-50	150.00 ea

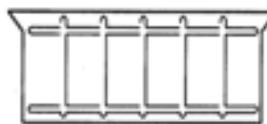

18-10757



81C-10758 & 21C-10759

PICKUP BED SIDES

1932BS-L	LH side only	1932	290.00 ea
1932BS-R	RH side only	1932	290.00 ea
3334BS-L	LH side only	33-34	290.00 ea
3334BS-R	RH side only	33-34	290.00 ea
3536BS-L	LH side only	35-36	290.00 ea
3536BS-R	RH side only	35-36	290.00 ea
1937BS-L	LH side only *	1937	290.00 ea
1937BS-R	RH side only *	1937	290.00 ea
3841BS-L	LH side only *	38-41	290.00 ea
3841BS-R	RH side only *	38-41	290.00 ea
4247BS-L	LH side only *	42-47	290.00 ea
4247BS-R	RH side only *	42-47	290.00 ea

For 37-47 sides assembled (spot welded) with rear brace, stake pockets, side support & chain bracket, add -A to part number. Add on to above prices 37-47 185.00 ea

Bed sides available with or without stake holes.

Add \$125.00 crating charge to above prices. Shipped by truck freight & costs provided upon request.



1932-1937 Bed side

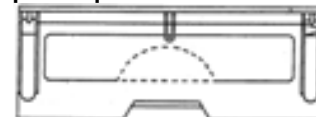

1938-1947 Bed Side

FRONT LOWER BED FILLER PANELS

Die-stamped. (Sides are not included with complete beds.)

50-10296	5" tall, LH	35-37	31.00 ea
50-10297	5" tall, RH	35-37	31.00 ea
81C-10298	4" tall, LH	38-41	30.00 ea
81C-10299	4" tall, RH	38-41	30.00 ea
21C-10300	3" tall, LH	42-48	30.00 ea
21C-10301	3" tall, RH	42-48	30.00 ea



50-10296



81C-10298



21C-10300

BED FLOOR COVERING

Stamped paint grip or primed steel.

18-10172	Stamped steel	1932	350.00 ea
46-10173	Stamped steel *	33-34	350.00 ea
50-10174	Stamped steel	35-36	350.00 ea
77-10175	Stamped steel	1937	350.00 ea
81C-10176	Stamped steel	38-41	350.00 ea
21C-10177	Stamped steel	42-50	350.00 ea

Add \$125.00 crating charge to above prices. Shipped by truck.



Typical Pickup Bed Floor Covering

* Available with or Inspection cover

PICKUP CROSSMEMBERS

18-20337	Rear, also fits 1937	32-36	60.00 ea
21C-20339	Rear	42-47	50.00 ea
3234FC	Front	32-34	60.00 ea
3537FC	Front	35-37	60.00 ea
3237FMC	Front middle	32-37	60.00 ea
3237RMC	Rear middle	32-37	60.00 ea
3841FMC	Front middle	38-41	45.00 ea
3841RMC	Rear middle	38-41	45.00 ea
81C-20338	Rear	38-41	50.00 ea
4250FCM	Front	42-47	45.00 ea
4250FMC	Front middle	42-47	60.00 ea
4250RMC	Rear middle	42-47	60.00 ea



18-20337



81C-20338 & 21C-20339

PICKUP TAILGATE CHAINS & BRACKETS

18-10204	Tailgate chain, 18 links	28-37	4.00 ea
81C-10205	Tailgate chain, 13 links	38-52	5.50 ea
B-78420	Tailgate chain cover, sewn black grain vinyl, 13" long	28-48	6.00 ea
A-10207	Chain top link, rolled iron rod Requires welding	28-37	3.00 ea
A-10207/1	Chain top link, same as above except stainless steel	28-37	5.00 ea
81C-10208	Chain top link, cast steel, requires welding	38-50	13.00 ea
A-10212	Tailgate chain bracket, stamped steel	31-37	9.00 ea
81C-10213	Tailgate chain bracket, stamped steel	38-50	8.00 ea



A-10207

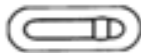

81C-10208



A-10212



81C-10213

PICKUP TAILGATE HOOKS & SPRING

A-10200	Tailgate hook, rolled iron rod	32-37	7.00 ea
81C-10201	Tailgate hook, rolled iron rod	38-52	7.00 ea
81C-10201/1	Tailgate hook, stainless steel	38-52	11.00 ea
46-10202	Tailgate hook retainer spring	33-50	5.75 ea



A-10200



81C-10201



46-10202

PICKUP TAILGATE HINGES, STRAPS & RODS

A-10218	Tailgate hinge rod, steel	31-36	25.00 ea
A-10218/1	Tailgate hinge rod, as above except stainless steel	31-36	35.00 ea
A-10215	Tailgate hinge, die stamped	31-36	6.50 ea
8C-8343018	Tailgate hinge, stamped steel	37-66	7.00 ea
8C-8343018-SS	Tailgate hinge, as above except stainless steel	37-66	16.00 ea
A-10322	Tailgate hinge strap, long 3 req'd 28-34, 2 req'd 35-36 *	28-36	22.00 ea
50-10323	Tailgate hinge strap, short 1 required, 35-36 *	35-36	22.00 ea



A-10215



8C-8343018



A-10322 & 50-10323

MISCELLANEOUS TAILGATE PARTS-continued

A-10318-L	Tailgate corner brace, LH *	31-37	6.50 ea
A-10319-R	Tailgate corner brace, RH *	31-37	6.50 ea
A-10320	Tailgate top bar, stamped steel, primed *	32-37	19.00 ea
81C-10315	Tailgate end, cast iron *	38-48	13.00 ea

***NOTE: Above items included tailgate assemblies 18-10137, 50-10138 & 77-10139**



A-10318/9



A-10320



81C-10315

PICKUP BEDSIDE PARTS

A-10268-F	Bed stake pocket, front	31-37	34.00 ea
A-10269-R	Bed stake pocket, rear	31-37	34.00 ea
81C-10270	Bed stake pocket, front or rear, RH or LH	38-50	25.00 ea
81C-10272-L	Rear stake pocket brace, LH	38-50	22.00 ea
81C-10273-R	Rear stake pocket brace, RH	38-50	22.00 ea
3847MB	Bed middle brace, requires fitting for 1937	37-48	16.00 ea



A-10268-F



A-10269-R



81C-10270



81C-10272-L



81C-10273-R



3847MB

PICKUP BED MOUNTING BOLTS & RIVETS

A-10328 *	Bed mounting bolts, 3-3/4", (2) required on 1932-1934, (4) required on 1935-1950	31-48	4.00 ea
50-10329 *	Bed mounting bolts, 8", (2) required on 1935-1950	35-50	8.50 ea
A-10330 *	Bed mounting bolts (2) required on 1932-1934, (2) required on 1935-1941	32-41	ASK

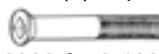

A-10328 & 50-10329



A-10330

*** Use only with stock (original style) steel floors**

3850HDB	Bed mounting bolt kit for custom wood floors, plain steel	38-50	ASK
3850HDBSS	Bed mounting bolts for custom wood floors, stainless steel	38-50	ASK
A-99017	Rivet kit. Kit includes enough to completely restore bed	31-56	22.50 kit
A-99023	Rivet setting tool, 1/4" cup diameter, use for riveting by hand	31-56	16.50 ea
A-99021	Rivet setting tool 1/4" use with air chisel tool	31-56	16.50 ea
A-99020	Rivet setting tool 3/8" use with air chisel tool	31-56	16.50 ea



A-99023



A-99020 A-99021

COMPLETE PICKUP BEDS

BED FLOORING KITS

Sub-floor wood originally used under the metal bed floor covering. Oak, show quality.

B-88012	Sub-floor, complete set.....	1932	260.00	set
46-88013	Sub-floor, complete set.....	33-34	260.00	set
50-88014	Sub-floor, complete set.....	35-36	260.00	set
77-88015	Sub-floor, complete set.....	1937	260.00	set
81C-88016	Sub-floor, complete set.....	38-41	275.00	set
21C-88017	Sub-floor, complete set.....	42-50	275.00	set



Typical Bed Flooring Kit

CUSTOM FLOOR WOOD KITS

All late 1931-1950 Fords came with a steel bed floor. However we offer an alternative kit which has oak wood and metal bed strips. These include special spacers, bolts and brackets which make it appear to be factory, and it's more economical than restoring to original. When ordering, specify year bed.

CFWK-P	Kit with <u>plain</u> steel bed strips and hardware	31-50	330.00	set
CFWK-SS	Kit with <u>stainless steel</u> bed strips and hardware	31-50	395.00	set



PLEASE CALL FOR DELIVERY TIME AND SHIPPING COSTS OF ABOVE WOOD FLOOR KITS

METAL BED STRIPS & HARDWARE

These bed strips come without mounting holes and are easily drilled and cut to length. Available in 2 different lengths in either plain or stainless steel.

A-66603	Plain steel, 79" long (1/2 ton).....	13.00	ea
A-66601	Plain steel, 97" long (3/4 ton).....	15.00	ea
A-66604	Stainless steel, 79" long (1/2 ton)	18.00	ea
A-66602	Stainless steel, 97" long (3/4 ton)	21.00	ea
A-55403	Mounting bolts for above strips, stainless steel, 1/4" X 2" long (nuts & washers not incl) .	1.25	ea



Note: Above Bed strips are subject to a UPS oversize shipping charge of \$25-\$35 (set of 5) whether drop shipped or picked up at our store.

BED FLOORING BOLT SETS

Holds the metal floor covering to the subrails underneath.

B-78011A	Bed flooring bolt set.....	1932	17.00	set
50-78011B	Bed flooring bolt set.....	35-36	17.00	set
77-78011C	Bed flooring bolt set.....	1937	17.00	set
81C-78011D	Bed flooring bolt set.....	38-41	17.00	set
21C-78011F	Bed flooring bolt set.....	42-48	17.00	set

CAB INTERIOR WOOD KIT & HARDWARE

All holes drilled. Hardwood. Complete set.

B-88037	Interior wood kit.....	32-33	165.00	kit
46-88038	Interior wood kit.....	1934	165.00	kit
A-65023	Seat wood to cab bolt, large flat head (10266).....	32-34	1.50	ea



B-88037

BED MOUNTING WOOD

50-88003	Bed mounting wood blocks, 2 pieces.....	35-37	40.00	pr
81C-88004	Bed mounting wood, 2 pieces..	38-41	125.00	pr



50-88003

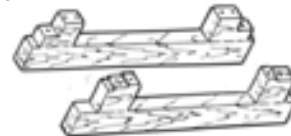

81C-88004

CAB MOUNTING WOOD

B-88033	Cab mounting wood set, 6 pieces.....	32-34	124.00	set
50-88034	Cab mounting wood, 2 pieces..	35-37	200.00	pr
81C-88035	Cab mounting wood, 2 pieces..	38-39	225.00	pr
01C-88036	Cab mounting wood, 6 pieces..	40-41	130.00	set



B-88033



50-88034



81C-88035

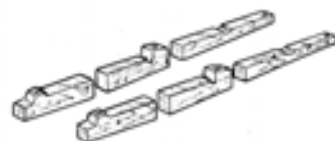

01C-88036

MISCELLANEOUS PICKUP CAB PARTS

A41000/850B	Patch panel for back of cab with bead, 44" long x 6" high	30-34	ASK
A-65018	Seat spring hook, holds lower edge of seat back, spring steel.....	32-34	6.00 ea
A-65019	Dispatch pocket, stamped steel, mounts to kick panel.....	32-34	22.50 ea



A-65018



A-65019

WINDOW GLASS SETS

All glass is clear AS1 safety glass 1/4" thick. This safety glass works very well and presents no fitting or installation problems. Your glass will be shipped by UPS in special boxes that insure safe delivery. Most factory shipments will be made within 14-21 working days of the receipt of order. The following codes are used below to describe the glass: **W = Windshield, D = Door Glass, Q = Quarter Glass, B = Back Glass, V = Vent Glass (Where "DD" appears, it indicates 2 door windows, "QQ" indicates 2 quarter windows, etc.)**

Roadster & Phaeton

VG50 W, B 32-39 175.00 set

3 Window Coupe*

VG51A W, DD, B 1932 305.00 set

VG51B W, DD, B 33-34 305.00 set

VG52 W, DD, B 35-36 305.00 set

5 Window Coupe

VG53A W, DD, QQ, B 1932 385.00 set

VG53B W, DD, QQ, B 33-34 385.00 set

VG54 W, DD, QQ, B 35-36 385.00 set

VG55 WW, DD, QQ, BB 37-39 430.00 set

VG56 WW, VV, DD, QQ, BB 1940 520.00 set

VG57 WW, VV, DD, QQ * 41-48 440.00 set

* Does not include rear window.

Tudor

VG58A W, DD, QQ, B 1932 405.00 set

VG58B W, DD, QQ, B 33-34 405.00 set

VG58C W, DD, QQ, B 35-36 405.00 set

VG59 WW, DD, QQ, BB 37-39 450.00 set

VG60 WW, VV, DD, QQ, BB 1940 540.00 set

VG61 WW, VV, DD, QQ * 41-48 460.00 set

* Does not include rear window.

Fordor

VG62A W, DDDD, QQ, B 1932 515.00 set

VG62B W, DDDD, QQ, B 33-34 515.00 set

VG62C W, DDDD, QQ, B 35-36 515.00 set

VG63 Deluxe, WW, DDDD, QQ, BB 37-39 560.00 set

VG63A Standard, WW, DDDD, QQ, BB 37-39 560.00 set

VG64 WW, VV, DDDD, QQ, BB 1940 650.00 set

VG65 WW, VV, DDDD, QQ * 41-48 520.00 set

* Does not include rear window.

Pickup

VG66A W, DD, B 1932 305.00 set

VG66B W, DD, B 33-34 305.00 set

VG67 W, DD, B 35-36 305.00 set

VG68 WW, DD, B 37-47 335.00 set

Convertible

VG71 WW, DD, VV, no rear window 1940 360.00 set

VG70 WW, DD, VV, no rear window 1941 360.00 set

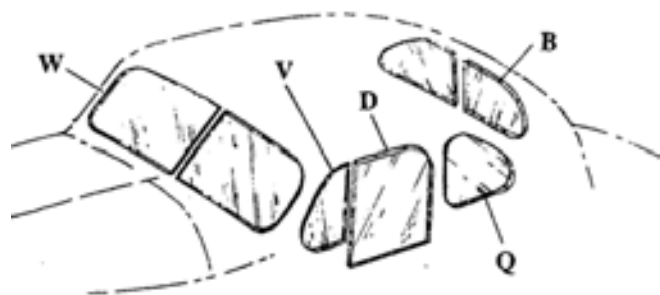

Window Glass

INDIVIDUAL PIECES OF GLASS

1941-1948 rear curved window glass not available

VGW1 Passenger & Pickup, one piece windshield 32-36 110.00 ea

VGW2 Passenger & Pickup, two piece windshield, price per peice 37-40 70.00 ea

VGW3 Passenger & 41-47 pickup, two piece windshield pieces 41-48 70.00 ea

VGFD All styles, front door window 32-48 65.00 ea

VGRD All styles, rear door window 32-48 65.00 ea

VGV All styles, front vent window 40-48 45.00 ea

VGQT Tudor only, rear quarter window moveable 32-48 75.00 ea

VGQA All styles except tudor, rear quarter window, moveable 32-48 50.00 ea

VGQF Rear quarter window, fixed 32-48 40.00 ea

VGB1 32-36 Car & pickup & 37-48 pickup, one piece rear window 32-36 65.00 ea

VGB2 Two piece rear window, price per piece 37-40 40.00 ea

VGBC One piece curved rear window 41-48 300.00 ea

VGQA All styles except tudor, rear quarter window, moveable 32-48 50.00 ea

VGQF Rear quarter window, fixed 32-48 40.00 ea

VGB1 32-36 Car & pickup & 37-48 pickup, one piece rear window 32-36 65.00 ea

VGB2 Two piece rear window, price per piece 37-40 40.00 ea

VGBC One piece curved rear window 41-48 300.00 ea

VGQA All styles except tudor, rear quarter window, moveable 32-48 50.00 ea

VGQF Rear quarter window, fixed 32-48 40.00 ea

VGB1 32-36 Car & pickup & 37-48 pickup, one piece rear window 32-36 65.00 ea

VGB2 Two piece rear window, price per piece 37-40 40.00 ea

VGBC One piece curved rear window 41-48 300.00 ea

WIND WING GLASS-PLAIN

VGWW32OC Open car 1932 50.00 ea

VGWW3334OC Open car 33-34 50.00 ea

VGWW3536OC Open car 35-36 50.00 ea

TINTED GLASS

All glass listed on this page is available tinted.

Tinting shades & upcharge noted below.

Green, comparable to modern automotive tint Add 10%.

Light grey, Light blackish tint appearance. Add 25 %

Light bronze, Light brown tint appearance. Add 25 %

ALWAYS SPECIFY THE EXACT YEAR AND BODY STYLE WITH ANY GLASS ORDER

WINDOW GLASS PATTERNS

Note: Patterns for all years & vehicles are not available. Only patterns noted below can be purchased

Windshield

78-741290-GP Convertible & station wagon. 37-40 5.00 ea

01A-7003110-GP Closed car and pickup 1940 5.00 ea

21A-7003110-GP All passenger cars 41-48 5.00 ea

Front Door

01A-7321410-GP Coupe, fordor and sedan delivery 1940 5.00 ea

Vent Window

01A-7021448/9-GP Closed car 1940 5.00 ea

Quarter Window

78-704220-S-GP Coupe 37-40 5.00 ea

Rear Window

78-704220-GP 1937 coupe & sedan, 1938 coupe & standard sedan, 1939-1940 coupe 37-40 5.00 ea

81A-704220-GP 1938 deluxe sedan, 1939-1940 sedan 38-40 5.00 ea

01C-8142084-GP Pickup 40-47 5.00 ea

GENERAL INFORMATION BOOKS

- 1932BK **1932 FORD BOOKS ***
Includes 3 volumes.
Volume 1 is 350 pages,
volume 2 is 264 pages, volume 3
is restoration & judging standards ... 1932 65.00 set
- 3334BK **THE 1933-1934 FORD BOOK ***
460 pages.....33-34 50.00 ea



1932BK



3334BK

- 3536BK **THE 1935-1936 FORD BOOK ***
164 pages.....35-36 29.00 ea
- 1937BK **THE 1937 FORD BOOK ***
220 pages.....1937 35.00 ea



3536BK



1937BK

- 3839BK **THE 1938-1939 FORD BOOK ***
238 pages.....38-39 35.00 ea
- 1940BK **The 1940 FORD BOOK ***
90 pages.....1940 N/A
- 4148BK **THE 1941-1948 FORD BOOK ***
168 pages.....41-48 25.00 ea

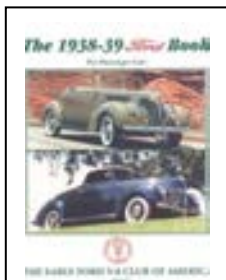

3839BK

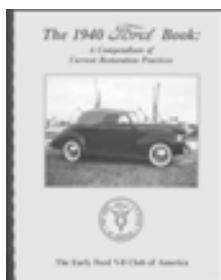

1940BK



4148BK

*These books have been compiled by members of the Early Ford V8 Club of America. Many factory photos, illustrations and specs on original vehicles A must for any restoration!

GENERAL INFORMATION BOOKS continued

ORDER & INFORMATION LINE 1- 508-278-3980

- VB131 **The Early Ford V8: As Henry Built It**, Well illustrated 219 pages.. 32-38 45.00 ea
- 4041P/UBK **1940-41 Pickup book**, descriptions and photos showing many facts & details, on these iconic trucks, 52 pages, softbound booklet 40-41 12.00 ea
- 3252BK **1932-1952 Pickup Book**
Good book to be used as a restoration guide, Many photos of original vehicles showing many close ups.140 pages..... 32-48 26.00 ea



VB131



4041P/UBK



3252BK

DETAIL & SPECIFICATION BOOKS

- VB1 **Restorer's Guide**, Ford 4 & 8 cylinder guide on interior, exterior and mechanical servicing, contains many useful charts & diagrams, plus passenger car body details listed by body style, 29 pages, 20 illustrations 1932 12.00 ea
- VB3 **Restorer's Guide**, Ford 4 & 8 cylinder guide on interior, exterior and mechanical servicing, contains many useful charts & diagrams, plus chassis and body style specifications, 29 pages, 15 illustrations 1933 1.00 ea
- VB5 **Restorer's Guide**, changes over 1932-1933 in paints, mechanics, windows and styling, 59 pages..... 1934 9.00 ea



VB1



VB3



VB5

- VB7 **Restorer's Guide**, guide to 1935 car, lists improvements made with new body & frame, 64 pages 1935 9.00 ea
- VB8 **Restorer's Guide**, Details and specifications of the Ford V-8 car for 1936, complete mechanical specs and breakdown of body specs by body style, 64 pages, 10 illustrations 1936 8.00 ea

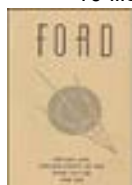

VB7



VB8

DETAIL & SPECIFICATION BOOKS continued

- VB41 **Ford Commercial Car & Truck**, contains invaluable information on paint specifications, engine and chassis specifications, photos and illustrations of most body styles, reprint of a sales brochure, 32 pages & 36 illustrations32-37 12.00 ea
- VB43 **Ford Commercial Car & Truck**, contains invaluable information on paint specifications, engine and chassis specifications, photos and illustrations of most body styles, reprint of a sales brochure, 36 pages & 68 illustrations38-41 12.00 ea



VB41

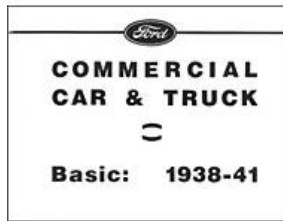

VB43

SALES BROCHURES

- VB97 **Sales Brochure**, new Ford V-8, poster style, fold out 1932 8.00 ea
- VB98 **A Great New Motor Car**, 24 page color book, shows all passenger models, features & specifications 1932 11.00 ea

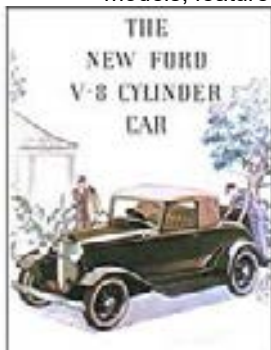

VB97

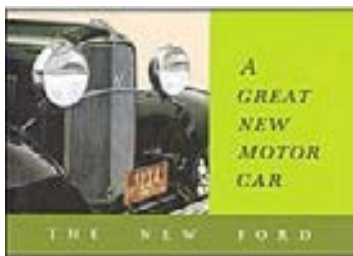

VB98

- VB99 **The New Ford Truck**, commercial sales brochure, fold out style 1932 8.00 ea
- VB100 **Sales Brochure**, fold out style, shows all passenger models and features for 1933 1933 8.00 ea

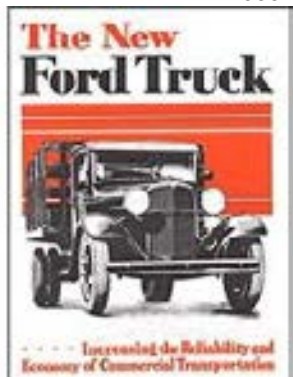

VB99



VB100

SALES BROCHURES continued

- VB102 **Sales Brochure/Commercial**, shows all truck body styles for 1933, fold out style 1933 8.00 ea
- VB103 **New Ford V-8**, 10 page booklet explains new features for 1933 1933 7.00 ea

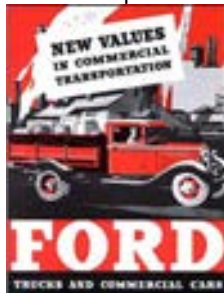

VB102



VB103

- VB104 **New Ford V-8**, fold out wall poster style, shows all passenger models for 1934 1934 10.00 ea
- VB106 **Sales Brochure/Commercial**, fold out style, shows all truck body styles for 1934 1934 10.00 ea



VB104



VB106

- VB107 **Sales Brochure For 1935**, shows all passenger body styles, 16 pages 1935 10.00 ea
- VB109 **Sales Brochure For 1936**, shows new features & details, 20 pages 1936 9.00 ea
- VB146 **Sales Brochure for 1936**, foldout style showing features 1936 8.00 ea



VB107



VB109

- VB111 **Sales Brochure/Commercial**, fold out style, shows all truck styles for 1936 1936 8.00 ea
- VB112 **Sales Brochure For 1937**, shows all passenger body styles, 20 pages 1937 10.00 ea

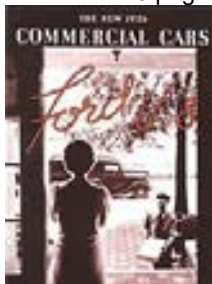

VB111



VB112

SALES BROCHURES continued

- VB225 **Sales Brochure For 1938**, shows passenger body styles, fold out poster style 1938 12.00 ea
- VB113 **Sales Brochure For 1939**, shows all passenger body styles, 16 pages..... 1939 10.00 ea
- VB195 **Sales Brochure For 1939, Trucks**..... 1939 12.00 ea



VB225



VB113

- VB114 **Sales Brochure For 1940**, shows all passenger body styles, 8 pages, large 9" x 10" 1940 10.00 ea
- VB115 **Sales Brochure**, Ford station wagon, shows standard & deluxe models, 4 pages 1940 10.00 ea

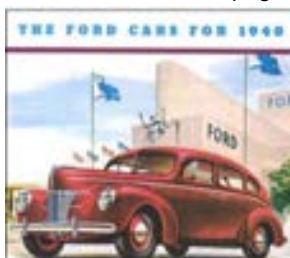

VB114



VB115

ACCESSORY BROCHURES

- VB101 **Approved Accessories**, genuine Ford accessories for 1933, fold-out style 1933 9.00 ea
- VB105 **Approved Accessories**, genuine Ford accessories for 1934, fold-out style 1934 8.00 ea
- VB108 **Approved Accessories**, genuine Ford accessories for 1935, fold-out style 1935 10.00 ea
- VB110 **Approved Accessories**, genuine Ford accessories for 1936, fold-out style 1936 8.00 ea
- VB226 **Approved Accessories**, genuine Ford accessories for 1938, fold-out style 1938 9.00 ea
- VB227 **Approved Accessories**, genuine Ford accessories for 1939, brochure, 6 pages..... 1939 8.00 ea
- VB228 **Approved Accessories**, genuine Ford accessories for 1940, 2-sided card 1940 8.00 ea



VB101



VB108

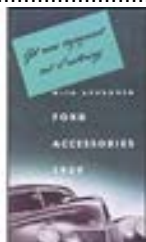

VB227



VB228

CHASSIS PARTS BOOKS

- VB34 **Chassis Parts List**, includes photos of several body styles, with type listing, includes body trim & parts nomenclature, 268 pages..... 32-37 36.00 ea
- VB38 **Chassis Parts List**, covers passenger cars & trucks, with Model Identification Chart, Body Type listing, and listing of Finish of Standard Parts, simplified wiring diagrams, 300 pages, 85 illustrations 38-41 38.00 ea
- VB120 **Chassis Parts & Accessories Catalog**, "The Green Book", detailed illustrations showing parts interchanges and applications, 802 pages 32-48 55.00 ea
- A2 **Parts Book & Price List**, covers engine & chassis, 27 pages, illustrated..... 1932 15.00 ea



VB138



VB120

BODY PARTS BOOKS

- VB32 **Body Parts List/V-8 & 4 Cylinder**, covers the Model B & V-8 passenger cars, identical for 4 & 8 cylinder models, includes body trim & parts nomenclature, with 20 body photos and body type listing, 321 pages..... 1932 20.00 ea
- VB33 **Body Parts List/Ford Passenger And Commercial Cars**, includes body trim & parts nomenclature, includes several photos of body styles, with body type listing, 76 pages 33-34 19.00 ea
- VB35 **Body Parts List/Ford Passenger And Commercial Cars**, covers passenger & commercial, with some truck parts, includes body trim and parts nomenclature, with body type listing, 76 pages, 13 photographs ... 35-36 19.00 ea
- VB37 **Body Parts List**, Ford, passenger and commercial with some truck parts, 77 pages 37-38 17.00 ea
- VB39 **Body Parts List**, contains original Ford part numbers & descriptions, includes several exploded line drawings & several photos of most body styles, 86 pages, 11 photographs 39-40 28.00 ea
- VB44 **1944-1952 Ford Body Parts Catalog**, for passenger cars and trucks, helpful in determining which parts fit which body styles, contains original Ford part numbers and descriptions, many exploded line drawings, 464 pages, 145 illustrations 44-48 51.00 ea

HARDWARE & TRIM BOOKS

PF2 **Trim & Hardware Reference Book**, detailed & illustrated, body trim and hardware, 168 pages.....32-38 24.00 ea

EARLY V-8 POSTER

VB87 **Lubrication Chart**, suitable for framing, 17" x 22"32-36 11.50 ea



SERVICE BULLETINS

VB2 **Service Instructions**, for the Ford V-8 & 4 cylinder car & truck, compilation of service bulletins reprinted, 88 pages..... 1932 16.00 ea

VB4 **Ford Service Bulletins**, for Ford V-8 of 1933, covers in great detail those problem areas known to require maintenance, contains reprints of Service Bulletins Volume 14, #'s 1-5, 88 pages, 64 illustrations..... 1933 15.00 ea

VB6 **Ford Service Bulletins**, details and specifications of the Ford V-8 car for 1934, covers many problem areas requiring regular maintenance, contains reprints from Service Bulletins Volume 15, #'s 1-9, 103 pages, 51 illustrations..... 1934 12.00 ea

VB127 **Ford Service Bulletins**, an assembly of the series of Service Bulletins originally issued periodically by the factory as a primary reference for the dealers, includes specification changes and the story of how the V-8 Ford came about, cameo reproduction of showroom master catalog, 544 pages, 750 illustrations, hardbound32-37 45.00 ea

VB128 **Ford Service Bulletins**, master indexed in a permanent new form, authorized dealer's revised copy with coverage extended to Lincoln, Zephyr & Mercury, 576 pages, 750 illustrations, softbound.....38-40 37.00 ea

VB129 **Ford Service Bulletins**, features all bulletins for the line that would become Ford's final expression under the traditional chassis engineering guidelines, covers all changes pertinent to production during these model years & includes the supplementary Troubleshooting Bulletins series, 384 pages, 360 illustrations, hardbound41-48 45.00 ea

COLOR CHIP BOOKS

VB25 **Refurbishing Manual For Early Ford V-8 Cars**, includes 48 Ditzler paint chips & painting tips, refinish nomenclature, Ford factory paint schedules, refinish schedules, troubleshooting, and more, with photographs of many body types, 36 pages, 109 illustrations 37-48 49.00 ea

RMB **Repaint Manual**, includes Ditzler paint chips, instructions for painting, 36 pages 32-36 30.00 ea



RMB

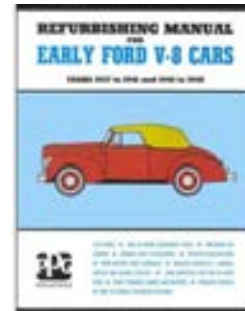

VB25

OPERATOR'S MANUALS/1932-1948

VB18 **Instruction Book Ford 4 Cylinder Cars & Trucks**, the owners handbook, with lubrication charts and detailed wiring diagrams, covers instrument use, headlight alignment, distributor, brakes, shocks, and more, 64 pages, 34 illustrations 32-34 12.00 ea

VB11 **Instruction Book/Owner's Manual**, covers oil, lubrication, instrument use, distributor, headlight alignment, electrical systems, carburetor adjustment, brakes, tires, shocks, and more, includes detailed wiring diagrams, with specifications and license data, 64 pages, 24 illustrations 1934 11.00 ea

VB26 **Operator's Manual**, V-8 Ford, 31 pages 1935 12.00 ea

VB17 **Reference Book Ford**, owner instructions for operation and maintenance, gives lubrication and wiring charts & servicing adjustments, 32 pages 1936 11.00 ea

VB20 **Ford Reference Book 1937**, with Ford V-60 specifications, the regular owner instruction manual, with lubrication charts and wiring diagrams, covers oil, instrument use, distributor, carburetor adjustment, electrical, headlight alignment, and more, 64 pages, 36 illustrations 1937 11.00 ea

VB21 **1938 Ford Reference Book**, for the 85 HP engine, with Ford V-60 specifications, includes lubrication chart & wiring diagrams, contains specifications & license data, covers distributor, carburetor, brakes, shocks, and more, 64 pages, 36 illustrations 1938 11.00 ea

OPERATOR'S MANUALS/1932-1948 continued

VB22	Ford Passenger And Commercial Reference Book , includes lubrication chart & wiring diagrams, contains specifications, license data, instrument use, headlight alignment, brakes, tires, shocks, and more, 64 pages, 34 illustrations.....	1939	11.00 ea
VB130	Mercury Reference Book , an Owner's Manual for the Mercury V-8, with lubrication chart & simplified wiring diagram, covers engine, ignition, fuel systems, transmission, steering gear, tires, and more, 62 pages, 29 illustrations.....	1939	10.00 ea
VB16	Reference Book Ford , owner manuals were for education of the car's owner & driver, 64 pages.....	1940	11.00 ea
VB23	1941 Ford Deluxe And Super Deluxe Reference Book , lubrication chart & detailed wiring diagrams, covers oil, headlight alignment, distributor, carburetor, instrument use, brakes, tires, and more, 64 pages, 39 illustrations.....	1941	12.00 ea
VB42	Reference Book, Passenger Car , supplies car & operation instructions for the car, 64 pages.....	1942	13.00 ea
VB46	Operator's Manual - 1946 Ford Passenger Car , models 69A & 6GA, with lubrication & simplified wiring diagrams, includes a chapter on specifications, with hydraulic & hand brake system diagrams, 44 pages, 17 illustrations.....	1946	13.00 ea
VB47	Operator's Manual - 1947 Ford Passenger Car , models 79A & 7GA, with lubrication & simplified wiring diagrams, includes a chapter on specifications, with hydraulic and hand brake system diagrams, 44 pages, 15 illustrations.....	1947	13.00 ea
VB48	Operator's Manual - 1948 Ford V-8 Passenger Car , with lubrication and simplified wiring diagrams, includes a chapter on specifications, with hydraulic & hand brake system diagrams, 39 pages, 12 illustrations.....	1948	13.00 ea

REPAIR & SERVICE MANUALS

VB12	The Ins & Outs of Early Ford Transmissions , An illustrated breakdown of early transmissions used in Ford cars, includes black & white drawings as well as photographs, 63 pages.....	32-50	35.00 ea
VB10	Repair Manual/Ford & Mercury V-8 Engines , information for the repair or overhaul of Mercury & V-8 engines (except 60 HP) manufactured from 1937-1948, inclusive/intended for use by everyone, the instructions begin with the engine removed from the vehicle, covers complete repair, 64 pages, 61 illustrations.....	37-48	17.00 ea

REPAIR & SERVICE MANUALS continued

VB13	1932 To 1936 Engine & Chassis Repair Manual , includes specifications for servicing and adjustments, includes detailed and simplified wiring diagrams, easy to read & understand, covers fuel, engine, clutch, ignition, electrical, carburetor, and more, 48 pages, 83 illustrations.....	32-36	31.00 ea
VB14	1937 & 1938 Engine And Chassis Repair Manual , includes specifications for servicing and adjustments, includes detailed and simplified wiring diagrams, easy to read & understand, covers fuel, engine, clutch, ignition, electrical, carburetor, and more, 36 pgs, 49 illustrations.....	37-38	31.00 ea
VB15	1939 & 1940 Engine And Chassis Repair Manual , includes specifications for servicing and adjustments, includes detailed and simplified wiring diagrams, easy to read & understand, covers fuel, engine, clutch, ignition, electrical, carburetor, and more, 44 pgs, 53 illustrations.....	39-40	31.00 ea
VB124	Rebuilding The Famous Ford Flathead , a step by step approach to rebuilding the famous "FLATTIE", covers all models from 32-53, a necessary guide for the flathead rebuilder, 140 pages, 81 detailed diagrams.....	32-53	35.00 ea
BK474D	Thunder Road Flathead , by Bill Jenkins, 10 valuable chapters of procedurals complete with pictures, diagrams, and helpful hints for Ford and Mercury flatheads, 84 pages, 61 photos.....	35-53	37.00 ea
VB125	Repair Manual , covers transmissions, clutches, overdrives, and PTO's, 80 pages.....	32-47	N/A
VB160	Ford Flathead V-8 Builders Handbook , tips on rebuilding Ford and Mercury V-8 flatheads for stock and high performance, covers boring, stroking, porting, and relieving, 154 pages, 500 illustrations.....	32-53	30.00 ea
VB240	Repair Manual , covers manual fuel system, maintenance of carburetors and fuel pumps, 60 pages.....	38-48	20.00 ea
VB241	Repair Manual , covers generating and starting systems, 42 pages.....	33-47	15.00 ea
VB224	Service Manual , lots of detail and illustrations on repairs & service, 240 pages, 102 illustrations.....	32-41	45.00 es
VB222	Shop Manual & Specifications And Adjustments , extremely detailed, lots of repair instructions and illustrations, the best book available for mechanical restoration, Ford & Mercury passenger cars and trucks, most complete factory shop manual ever published for these years, 475 pages, 550 illustrations.....	39-48	60.00 ea
VB244	Service manual Ford, Lincoln Mercury Cars & pickups , 224 pages, softbound.....	42-48	12.00 ea

MAINTENANCE BOOKS

- VB9 **Ford Maintenance Manual**, to help owners keep cars running during WWII shortages, was issued by the company, 64 pages32-48 12.00 ea
- VB24 **Service Manual – Ford, Mercury, And Lincoln**, covers the servicing of 6, 8, and 12 cylinder engines and chassis of all three model years, with a section of car photos & body part illustrations, reprint of original Service Manual 3606-46, 256 pages, 143 illustrations46-48 32.00 ea
- VB123 **The Complete Ford Owner's Handbook Of Repair And Maintenance**, covers all model's 1932-1955, including V8-60, explains many repair & tune-up jobs, includes wiring diagrams, specification tables, and many exploded line drawings, 224 pages, 246 illustrations32-48 30.00 ea

RADIO BOOKS

- VB150 **Radio Installation Handbook**, ash tray radio, copy of original33-34 10.00 ea
- VB151 **Radio Installation Handbook**, copy of original, 8 pages35-E36 10.00 ea
- VB152 **Radio Installation Handbook**, copy of original, 8 pages L36 10.00 ea
- VB153 **Radio Installation Handbook,5** copy of original, 8 pages 1937 10.00 ea
- VB154 **Radio Installation Handbook**, copy of original, 8 pages 1938 10.00 ea
- VB155 **Radio Installation Handbook**, copy of original, 8 pages 1939 10.00 ea
- VB156 **Radio Installation Handbook**, copy of original, 8 pages, Philco 1940 10.00 ea
- VB157 **Radio Installation Handbook**, copy of original, 8 pages 1942 10.00 ea
- VB158 **Radio Installation Handbook**, copy of original, 8 pages 1946 10.00 ea
- VB159 **Radio Installation Handbook**, copy of original, 8 pages47-48 10.00 ea

GENERAL INFORMATION MECHANICAL BOOKS

- VB116 **K.R. Wilson Timing Fixture Instructions**, explains how to use this accessory in order to properly set up the Ford distributor, 4 pages32-48 16.00 ea
- KRW3 **K.R. Wilson Catalog**, 1936 version covers early V-8 Ford cars & trucks, all tools are pictured in detail with a full description of their use, 104 pages N/A
- KRW4 **K.R. Wilson Catalog**, 1940 version covers late V-8 Ford, Mercury and Lincoln-Zephyr, incredible listing of tools with pictures & full descriptions, 128 pages N/A
- VB220 **Eaton Axle Handbooks**, 2 speed large commercial axles, covers lubrication, service, adjusting, disassembly & assembly, 15 & 19 pages48.00 set

COLUMBIA BOOKS

- VB90 **Columbia Rear Axle**, installation instructions, 11 pages 33-34 10.00 ea
- VB91 **Columbia Rear Axle**, installation instructions, 11 pages 35-36 10.00 ea
- VB92 **Columbia Rear Axle**, installation instructions, 11 pages 1937 10.00 ea
- VB93 **Columbia Rear Axle**, installation instructions, 3 pages 1940 10.00 ea
- VB94 **Columbia Rear Axle Parts List**, 35-40 Ford, 39-40 Mercury, and 36-40 Lincoln, 12 pages 35-40 10.00 ea
- VB95 **Columbia Rear Axle Parts List**, 41-48 Ford, Mercury, & Lincoln Zephyr, 8 pages 41-48 10.00 ea
- VB96 **Columbia Rear Axle**, installation instructions, Ford, Mercury, and Lincoln Zephyr, 10 pages 41-48 10.00 ea
- VB96P **Columbia Rear Axle Pamphlet**, published by Ford for dealers, explains how it works, 4 pages 42-48 3.50 ea

AIR CLEANER DECALS

- DF1586 Dry style air cleaner 1933 10.00 ea
- DF1 Dry style air cleaner 34-36 12.00 ea



DF1586



DF1

- DF2 Dry style air cleaner 37-38 10.00 ea
- DF6 Hat style dry air cleaner 39-41 10.00 ea

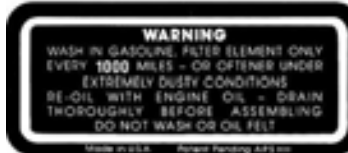

DF2



DF6

- DF739 Dry style air cleaner 46-48 10.00 ea



DF739

- DF462 Oil bath air cleaner 37-38 8.00 ea

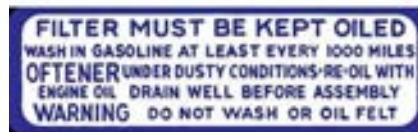

DF462

- DF4 Oil bath air cleaner, passenger and truck 39-41 8.00 ea
- DF28 Oil bath air cleaner, passenger and truck 42-48 8.00 ea



DF4



DF28

AIR CLEANER DECALS continued

- DF26 Oil bath caution air cleaner, passenger & truck32-48 10.00 ea
- DF65 Accessory oil bath cleaner, passenger & truck35-40 10.00 ea



DF26

DF65

- DF754 Heavy duty oil bath air cleaner, passenger & truck39-41 10.00 ea
- DF357 Truck oil bath air cleaner.....48-51 10.00 ea



DF754

DF357

ENGINE COMPARTMENT DECALS

- DF5 AC oil filter, passenger & truck.....35-49 10.00 ea
- DF64 FRAM oil filter, passenger and truck, set of 239-51 10.00 set
- DF3 Oil filter cap, passenger & truck ...35-36 10.00 ea



DF5

DF64

DF3

- DF27 Fan blade oil42-48 10.00 ea
- DF685 Windshield washer bottle bracket46-48 10.00 ea
- DF1160 TRICO windshield washer decal ..46-48 10.00 ea



DF27

DF685

DF1160

FORD OVAL DECALS

- DF361 "FORD" oval, 3-1/2" x 1-1/2"10.00 ea
- DF362 "FORD" oval, 6-1/2" x 3".....10.00 ea
- DF363 "FORD" oval, 9-1/2" x 4-1/2"10.00 ea
- DF364 "FORD" oval, 17"12.00 ea
- DF531 Genuine Ford parts 3" x 1 1/8"10.00 ea



INTERIOR DECALS & MORE

- DF7 Columbia windshield..... 32-48 10.00 ea
- DF581 Tire & oil pressure in glove box ... 1941 10.00 ea
- DF674 Tire & oil pressure in glove box ... 1942 10.00 ea



DF7

DF581

DF674

- DF128 Tire & oil pressure 46-48 10.00 ea
- DF126 Manifold heater, passenger and truck..... 39-40 10.00 ea
- DF491 Manifold heater instruction tag, passenger & truck..... 39-40 10.00 ea



DF128

DF126

DF491

- DF1223 Manifold heater instruction tag..... 1940 9.00 ea
- DF1222 Hot air heater instruction card..... 1940 9.00 ea
- DF24 Heater instruction tag 46-48 8.00 ea
- DF11 Clock warranty tag (New Haven) . 37-48 10.00 ea



DF1223

DF1222

DF24

DF11

- DF9 Battery warranty certificate 39-53 8.00 ea
- DF34 Owners service certificate 39-41 8.00 ea
- DF8 Service policy 39-40 8.00 ea
- DF144 Service policy 41-48 8.00 ea
- DF696 Owners manual envelope..... 46-48 10.00 ea



DF9

DF34

DF8

DF144

DF696

- DF21 Radio warranty tag 1940 8.00 ea
- DF22 Radio warranty tag 46-48 8.00 ea
- DF23 Radio instruction tag..... 46-48 8.00 ea
- DF591 Antenna instruction tag 37-39 8.00 ea
- DF106 Jack instruction tag 1939 8.00 ea
- DF18 Jack instruction tag 1940 8.00 ea
- DF681 Jack instruction tag 1941 8.00 ea
- DF682 Jack instruction tag 1942 8.00 ea

PATENT PLATES

Includes drive screws unless otherwise noted

B-14001	Car and pickup.....	32-34	5.00 ea
48-14001	Car and pickup.....	35-36	5.00 ea



B-14001



48-14001

78-14001	Car and pickup.....	37-39	5.00 ea
01A-14001	Car and pickup.....	40-48	5.00 ea



78-14001



01A-14001

7C-14001	Pickup only (This plate great for custom applications!)	48-52	6.00 ea
99A-14001	Mercury.....	39-48	6.00 ea

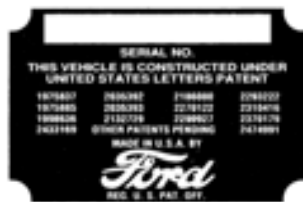

7C-14001



99A-14001

BODY NUMBER PLATES

Includes drive screws unless otherwise noted

40-14002	Car and pickup.....	33-34	4.00 ea
48-14002	Car and pickup.....	1935	4.00 ea

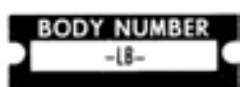

40-14002

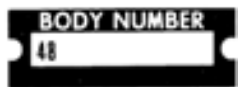

48-14002

68-14002	Car and pickup.....	1936	4.00 ea
78-14002	Car and pickup.....	1937	4.00 ea

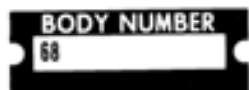

68-14002

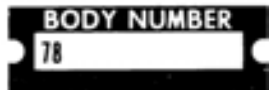

78-14002

U-18651-P	Blank body number plate	6.00 ea
A-18654-U	Blank VIN number plate, 2 1/2" x 1", drive screws not Included (available below)	10.00 ea

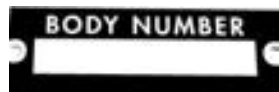

U-18651-P

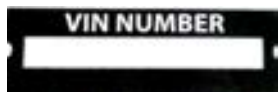

A-18654-U

A80100	Drive screw kit, set of 10, 3 different sizes.....	09-52	1.50 set
--------	--	-------	----------

RESTORATION ITEMS

OIL & GREASE RELATED

M-400	600W oil for use in transmission (2 3/4 pts.) rear axle (2 1/2 pts.) and steering boxes. Viscosity is approximately equivalent to SAE 250. One quart plastic bottle ...	32-48	17.50 qt
M-400-L	600W oil as above but has a slightly higher (thinner) viscosity	32-53	9.00 qt
GREASE	Timken wheel bearing grease, 1 lb container.....	28-48	6.50 ea
ZDDPLUS	Oil additive to add zinc to correct level in "Flathead" motors as required per original specs. 4 oz bottle which can be added at each oil change	28-53	11.00 ea



PAINT- ENGINE ENAMEL & FORD BLUE

Engine enamel

RSP6	Ford green, 11 oz. spray can *	32-41	8.00 ea
RSP6P	Ford green, 1 pint can	32-41	12.00 ea
RSP6Q	Ford green, 1 quart can	32-41	23.00 ea
RSP54	Ford blue, 11 oz spray can, 42-48 cars & 41-48 pickups *.....	41-48	8.00 ea

*NOTE: SPRAY CANS CANNOT BE SHIPPED IN US MAIL, ONLY VIA UPS



Spray can



Pint or quart can

SHOCK ABSORBER FLUID

A-18099	Pint, does all 4 shocks	8.00 pt
---------	-------------------------------	---------

CLINCH & CAGE NUTS

A-80055	Clinch nut, 12-24 thread	32-48	.50 ea
A-80056	Clinch nut, 10-32 thread	32-48	.75 ea
A-80057	Clinch nut, 1/4"-20 thread	32-48	1.00 ea
A-80059	Clinch nut, 5/16"-24 thread	32-48	3.00 ea
A-80058	Clinch nut, 3/8"-24 thread	32-48	7.00 ea
B-803145-B	Cage nut, 1/4"-20 thread	32-48	1.50 ea
B-803145-A	Cage nut, 5/16"-24 thread	32-48	2.00 ea
B-803145-D	Cage nut, 3/8"-24 thread	32-48	3.00 ea
B-803145-E	Cage nut, 1/2"-13 thread	32-48	3.00 ea



Clinch Nut



Cage Nut

RESTORATION ITEMS continued

REAR WHEEL PULLERS

- WK4235 Knock off type 3.00 ea
- A-1113-T Clamp on type..... 100.00 ea



WK4235



A-1113-T

SAFETY WIRE

- SAFETYWIRE .032 dia stainless steel lock wire, 1/4 lb spool, (90 feet) 9.50 ea



WINDOW INSTALLATION TOOLS

- TL-1002 Ball end hook tool for rubber glass seal 17.50 ea
- TL-1001 Window seal tool stick..... 2.00 ea



TL-1002



TL-1001

ACCESSORIES

RUNNING BOARD STEP PLATES *

Polished Die Cast Aluminum

- A-16400-BS "Ford" oval logo, 8 1/4" wide x 6 1/2" 50.00 pr
- 8C-16400-BS F-100 pickup logo, 10 3/4" wide x 5 1/2" 60.00 pr



A-16400-BS



8C-16400-BS

- NE-16400-DLX Plain black rubber insert, has small hole in toe plate to mount emblem 11 1/2" wide x 7 1/2" 65.00 pr
- A-16400-E Step plate emblem for NE-16400-DLX... 19.75 pr



NE-16400-DLX (FORD emblem sold separately)

- A-16400-MBK Mounting screw kit for step plate Stainless steel, mounts pair 2.00 kit

*** Note: When considering the purchase of these step plates, be sure to check for 2" clearance from running board to bottom of door to allow for clearance of step plate lip.**

ACCESSORIES continued

FOG LAMPS (AMBER LENS)

- B-18207F6A 6 volt with "FORD" lettering 155.00 pr
- B-18207F12A 12 volt with "FORD" lettering N/A
- B-18207-FAB6 Replacement amber bulb, for above lamp 6 volt, 4 1/2" O D 29.00 ea
- B-18207-FAB12 Replacement amber bulb, for above lamp, 12 volt, 4 1/2" O D..... 20.00 ea

DRIVING LAMPS (CLEAR LENS)

- B-18207F6C 6 volt with "FORD" lettering 155.00 pr
- B-18207F12C 12 volt with "FORD" lettering 155.00 pr
- B-18207-FCB6 Replacement clear bulb, for above lamp 6 volt, 4 1/2" O D 29.00 ea
- B-18207-FCB12 Replacement clear bulb, for above lamp, 12 volt, 4 1/2" O D..... 22.00 ea



Fog / Driving lamps

LICENSE PLATE LIGHT & BRACKET

Polished stainless steel

- HR-13550 License plate light and bracket, 12 volt..... 50.00 kit



KEY FOBS - FORD SCRIPT

- KC-1 Key chain, chrome with blue oval 5.00 ea
- KC-2 Key chain, plastic with slide in return address label 5.00 ea



KC-1



KC-2

SPOKE BRUSH

- BRUSH For wire and spoke wheels 6.00 ea



JOE'S ANTIQUE AUTO PARTS
 267 W. HARTFORD AVE.
 UXBRIDGE, MA 01569



ORDER & INFO LINE 1-508-278-3980
TOLL FREE 1-800-508-3980
24 HOUR FAX 1-508-278-2766
EMAIL: JOESANTIQUE@CHARTER.NET

NAME _____ DATE _____ CATALOG NO _____
 ADDRESS _____ YEAR OF CAR _____
 CITY _____ BODY STYLE _____
 STATE _____ ZIP _____ IF ANY ITEM IS OUT OF STOCK:
 PHONE _____ EMAIL _____ REFUND IMMEDIATELY _____
 BACKORDER UP TO TWO WEEKS _____
 BACKORDER UP TO 1 MONTH _____
 SHIP ORDER COMPLETE UP TO TWO WEEKS _____

QTY	PART NUMBER	PG#	DESCRIPTION	EACH	TOTAL

Please select your shipping preference below:
 Priority Mail UPS Least expensive available
 Shipping charge will be added at time of shipment based on your selection above.
 If a shipping charge is required prior to placement of an order, contact us with the items you require & we will advise cost, Otherwise we will charge the actual cost.

TOTAL COSTS OF PARTS	
MASS RESIDENTS ADD 6.25% SALES TAX	
SHIPPING	XXXXX
TOTAL	

PLEASE INDICATE METHOD OF PAYMENT

CHECK OR MONEYORDER MASTER CARD VISA DISCOVER COD

CREDIT CARD NUMBER _____

FORM 0717

EXPIRATION DATE ____ ____ CVV CODE ____ ____ SIGNATURE _____
 (Last 3 digits on back of card)

GENERAL INFORMATION- ANTIQUE AUTO PART SALES

PHONE ORDERS & INFORMATION Call 1-508-278-3980 or toll free 1-800-508-3980.

E-MAIL ORDERS OR CORRESPONDENCE joesantique@charter.net

FAX ORDER 1-508-278-2766

TELEPHONE HOURS Monday, Tuesday, Wednesday & Thursday 9:00 A.M. to 4:30 P.M. Closed Friday, Saturday, Sunday & major holidays. Visit us by appointment only at mutually convenient times. When visiting us **ALWAYS** call first.

PRICES All prices in this catalog are subject to change without notice.

SHIPPING We ship using UPS or USPS Priority mail both in domestic & export out of country. When ordering, please specify your choice. If a shipping charge is required prior to placing an order, contact us with the items you need & we can provide these cost option

SALES TAX All Massachusetts residents add 6.25% for sales tax. All items picked at store also subject to this tax.

PAYMENT We accept money orders, checks, Visa, Master card and Discover.

GUARANTEE All parts guaranteed and will be replaced for 30 days when used as originally intended. In any and all cases we are liable for purchase price of part only.

DAMAGE/MISSING GOODS If merchandise was damaged in shipping or if carton arrives opened, check for damaged and/or missing goods. Notify carrier of any damage at once. Claims must be taken up with the carrier. Keep the goods in the original carton for inspection.

RETURNS Items may be returned for a full refund they have been not been used or damaged within 30 days of purchase. All parts returned must have a copy of the original invoice and an explanation for the return. Parts returned in soiled boxes or packaging will be subject to a 10% restocking fee. Special order items are non-returnable.

FORD SCRIPT PRODUCTS All Ford script products offered in this catalog are Official Licensed Products of the Ford Motor Company by the manufacturer.

Your business is always appreciated!

Reproduction of this catalog either in whole or in part without the express written consent of Joe's Antique Auto is forbidden.

Not responsible for typographical errors in this catalog.



DIRECTIONS TO JOE'S ANTIQUE AUTO

267 WEST HARTFORD AVENUE, UXBRIDGE, MA 01569

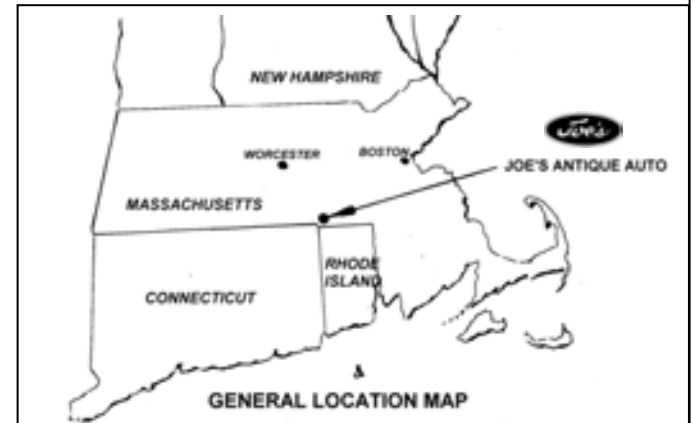

**WHEN VISITING US
WE RECOMMEND
CALLING FIRST**

1-508-278-3980



1932 Tudor



1948 Tudor



1934 Roadster

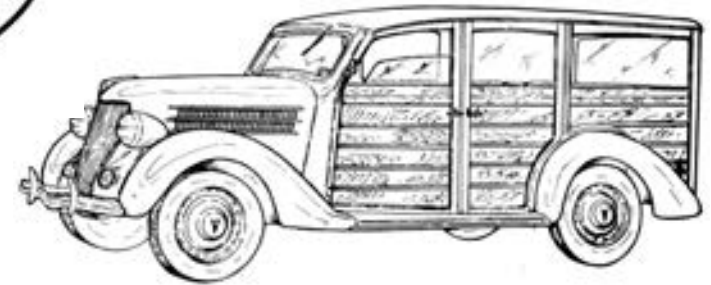

1936 Station Wagon



1936 Pickup



1939 Deluxe Coupe

Orders & Information: 1-508-278-3980

Toll Free 1-800-508-3980

Ask about Joe's Gift Certificates-available in any denomination